

HOPE

TECHNOLOGY

SCREW-ON REAR HUB 7/8 SPEED Instructions

The HOPE hub as supplied will usually be built to suit a 7 speed freewheel configuration . See Fig.1.

To convert hub from 7 speed to 8 speed

1. Remove spacers 2 and 3 from non-drive side and spacer 7 from drive side.
2. Support drive side spoke flange, use special tool no. HTT167. If tool is not available use a suitable bush or a pair of parallels. See Fig. 3.
Using a soft hammer (plastic or hide) tap spindle end on non-drive side until spindle, drive side bearing and 5mm spacer are released.
Once the bearing clears its housing the spindle will slide out. The non drive side bearing will remain in the hub body and need not be removed.
3. Pull off the drive side bearing and 5mm spacer from spindle. Refit the spacer onto the spindle non drive side.
4. Support wheel or hub on bush tool no. HTT169 non drive side down and re-load spindle non drive side back into hub. Ensure 5mm spacer does not drop off spindle. See fig 4. Slide bearing and bush tool no. HTT169 over spindle end and tap bearing until fully seated. Re-fit spacer item2 to non drive side and re-fit spacers items 3 and 7 to drive side. See Fig. 2.

NOTE : Radial building of HOPE hubs is not recommended unless specifically designed for this purpose.

HOPE TECHNOLOGY

SCREW-ON REAR HUB 7/8 SPEED

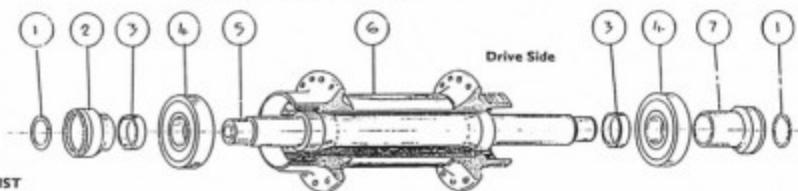

PARTS LIST

Item	Description	Qty.
1.	O' Ring	2 off
2.	Spacer (15mm long)	1 off
3.	" (5mm long)	2 off
4.	Bearing 6001 2RS	2 off
5.	Spindle	1 off
6.	Hub Body	1 off
7.	Spacer (28.5mm long)	1 off

Fig 1. Shows hub built to suit 7 speed freewheel
Spacers (item 3) are on left side of bearings (item 4).

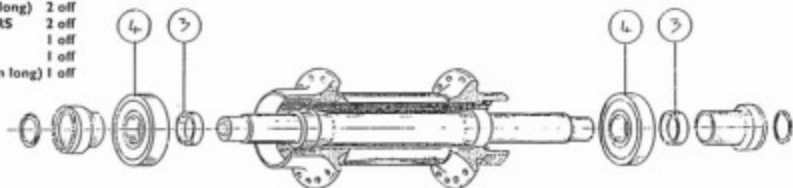

Fig 2. Shows hub built to suit 8 speed freewheel
Spacers (item 3) are on right side of bearings (item 4).

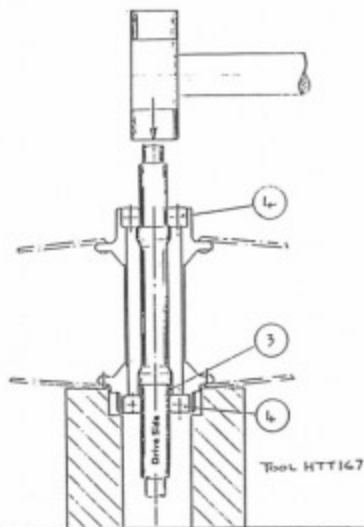

FIG 3

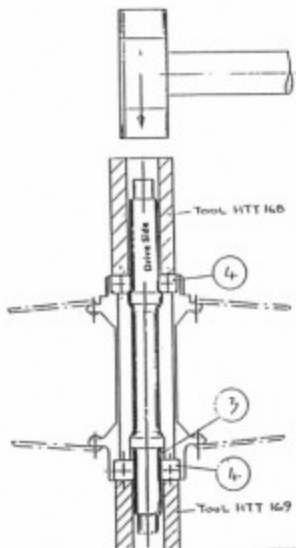

FIG 4