

What is the Tsali SpeedCheck™ hub about?

- The front (15 mm oversized) axle is constructed of a metal matrix material that has a "high specific stiffness". This means that the Tsali axle will be up 68% stiffer than our competitors typical aluminum axle.
- The Tsali SpeedCheck hub uses an 18mm hub cap and caliper for a more positive interface with suspension fork drop outs, yielding a more laterally rigid front end.
- The center line of the hub flange is located directly over the bearing center line. Radial loads are transmitted through the bearing with no added bending or twisting forces applied to the bearing. This allows smoother running and extended life for the bearings.
- The hub flanges are angled inward at 5 degrees to equalize the bending loads of the spokes. The spokes straight path to the rim, provides a longer spoke life at a higher tension.
- The special threaded hub cap is designed so that you can adjust the bearing load from one side of the hub, and so that it is simple to service.
- The Tsali SpeedCheck hubs use a technically designed flange in which the rotor mounts onto. This "fixed" type of rotor will eliminate any drag from the pads.
- When building a front wheel with the Tsali SpeedCheck front hub, it is necessary to "dish" the wheel to allow clearance to the SpeedCheck's rotor. A 9 mm spacer has been enclosed for proper dishing and truing. This spacer simulates the area to be occupied by the caliper axle locator.

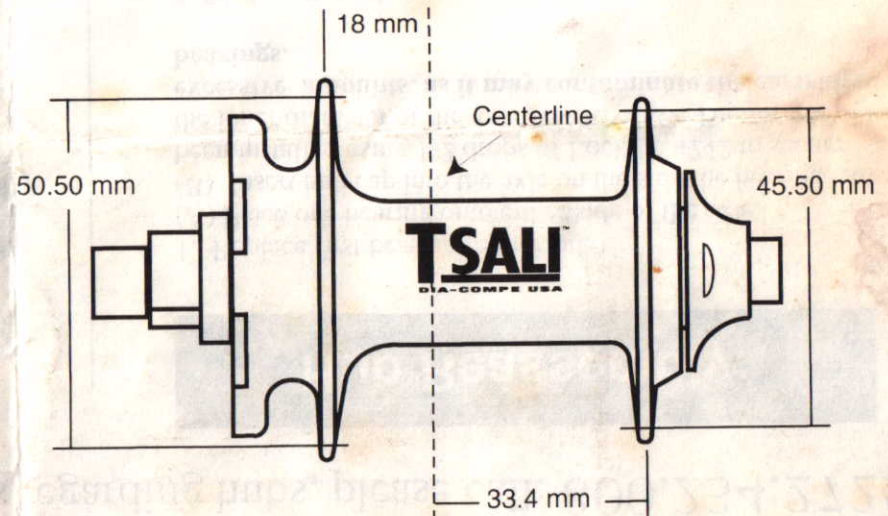

Tsali SpeedCheck™ (Front) wheel building Specifications

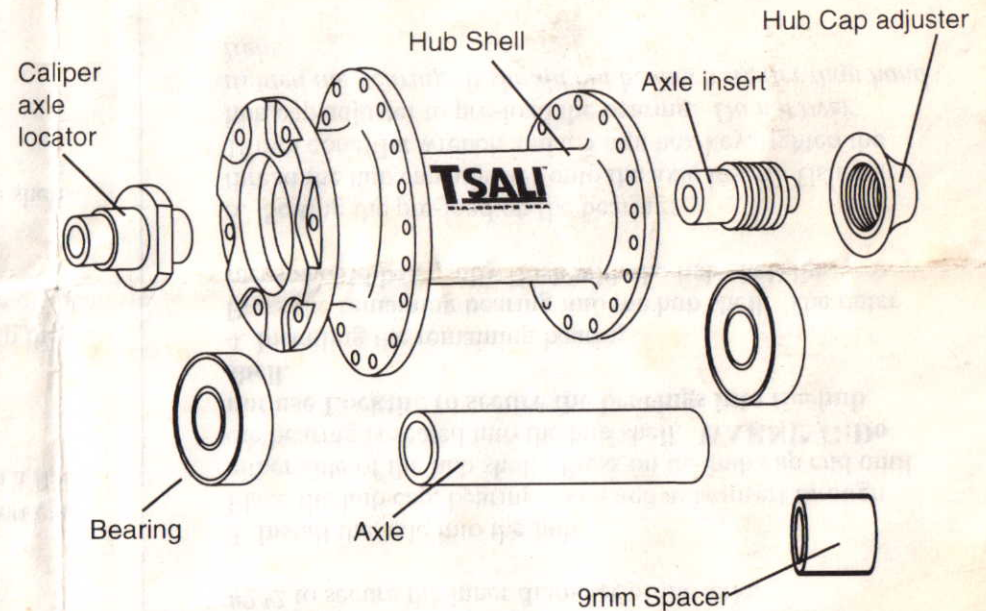

Technical Service: Any Questions regarding hubs, please call: 800.234.2725

This Tsali SpeedCheck front hub utilizes sealed cartridge bearings that should require little or no maintenance. If for any reason the cartridge bearings should need to be replaced; please follow these guidelines.

Hub Dissassembly:

1. Remove skewer from Tsali SpeedCheck hub.
2. Remove adjustable hub cap:
Place a 5mm hex key into the axle insert and unthread the hub cap adjuster with a 19mm flat or cone wrench. You can now remove the hub cap adjuster.
3. Removing the axle:
The caliper axle locator, (1) bearing, and the axle insert can now be removed out of the hub shell, by tapping with a flat object on the top of the axle insert.
4. Removal of hub cap from axle:
Carefully secure the axle by it's outer diameter and tap the hub cap out with a punch. The bearing will now slide off of the axle.
5. Press or punch the remaining bearing from the hub shell.
WARNING: Do not press on the inner race of the bearing, doing so may cause damage.

DIA-COMPE
USA

Hub Reassembly:

1. Replace first bearing (either side):
(A) Place one bearing onto either side of the axle.
(B) Insert hub cap into the axle on the side the bearing has been installed using 1-2 drops of Loctite #242 to secure the inner diameter of the axle. **WARNING: Do not use excessive amounts, as it may contaminate the cartridge bearings.**
2. Replace the axle insert:
If necessary, you may now press the axle insert into the opposite side of the hub axle using 1-2 drops of Loctite #242 to secure the inner diameter of the axle.
3. Install the axle into the hub:
Place the hub cap, bearing, axle, and axle insert through either side of the hub shell. Press on the hub cap end until the bearing is seated into the hub shell. **WARNING: Do not use Loctite to secure the bearings into the hub shell.**
4. Installing the remaining bearing:
Press the remaining bearing into the hub shell. The outer races should be equally flush with the hub shell lip.
5. Setting the pre-load on the bearing:
thread the hub cap adjuster onto the axle insert. Using a 19mm cone/flat wrench and a 5 mm hex key, tighten the hub cap adjuster to pre-load the bearing. *Do not over tighten the bearing- it should not be much tighter than hand tight.*
6. Set up: To ensure proper set up, place the skewer through the hub and install the hub/wheel on the fork. Close the quick release as normal and allow the adhesive to dry for 2-3 hours before use.