



www.mavic.com



TECHNICAL MANUAL



03

THIS DOCUMENT ONLY CONCERNS THE NEW PRODUCTS IN 2003.

THIS DOCUMENT UPDATES THE EXISTING TECHNICAL INFORMATION AND SHOULD THEREFORE BE KEPT IN A SAFE PLACE FOR AN UNLIMITED LENGTH OF TIME ALONG WITH THE MANUALS FROM PREVIOUS YEARS.

ALL INFORMATION CONCERNING THE EXISTING PRODUCTS IN THE PREVIOUS PRODUCT RANGES CAN BE FOUND IN THE TECHNICAL MANUALS PRINTED SINCE 1997.

YOU CAN GO ON-LINE TO THE WEBSITE www.tech-mavic.com TO FIND ALL THE EDITIONS OF THIS MANUAL SINCE 1997.

THE PRINTED EDITIONS ARE AVAILABLE AT YOUR USUAL CONTACTS.

THE NEW 2003 TECHNICAL MANUAL

The 2003 Technical Manual, which is essential to ensuring the maintenance of Mavic® products, consists of 3 main parts:

- wheels ;
- rims ;
- components, tools and customer service.

You will find two types of technical information in each one of these parts:

- Product drawings showing individual part numbers.
- Procedures to properly maintain our products.

Also the procedures to follow concerning the warranty and Mavic® Customer Service Center.

As we have already mentioned, this document only offers technical information regarding the modifications of the 2002 products and new Mavic® products in the 2003 product range. Therefore, it concerns:

- The wheels: Cosmos, Speedcity™, Crossride, Crossmax™ SL, Crossmax™ SL Disc, Crossmax™ XL, Crossmax™ XL Disc and Deemax® UST.
- The rims: CXP22, X3.1, D3.1 Disc and X139 Disc.

We hope this document will meet your needs and we are always open to listen to any suggestions to improve on it.

Thank you for your confidence in us and have a good 2003 season.

MAVIC® CUSTOMER SERVICE

Our objective is that you be the only service partner for the consumer.

You are also assured that through the use of our worldwide Mavic® Service Center (MSC), you will benefit from maximum assistance, the best possible service and professional advice.

Mavic® MSC will be at your disposal to guide you through the necessary procedures in the event you need to return a part, make repairs, make standard replacements, or to send you spare parts necessary for product maintenance.

We simply ask you to **contact Mavic® MSC prior to all returns (see page 42)** to obtain the proper procedures for correct returns. Mavic® will only accept authorized returns.

For additional information contact your MSC or consult the last pages in this technical manual.



HYPERTEXT LINK <http://www.tech-mavic.com> www.tech-mavic.com

The number of dealers connected to the Internet has been increasing for several years. More and more are looking for precise technical information about our products. Therefore, we have put all our technical manuals since 1997 on line.

By going to our e-mail address : www.tech-mavic.com, you will find all this information. To be connected, you will need a personal code and a password. These access codes will be communicated by your usual contacts: reps, assistant reps, Customer Service, Mavic® Service Center...



Among other things on this site, you will find:

- All the technical details on all the Mavic® products on the market since 1997, wheels, rims, components, organized by discipline and by product.
- 3 recap charts of spoke lengths and references on all our wheels, which will help you to better manage your spoke stock;
- A program for calculating the spoke length: starting with a given Mavic® rim, select the drilling and lacing, pattern, the width of your hub, as well as the diameter flanges and the distance between the flanges and the frame support or fork; the spoke length that corresponds to the building of your wheel will be automatically calculated;

We hope that this tool will be able to meet your needs. Do not hesitate to inform us of any possible dysfunction or improvements that you would like us to make.

CONTENTS

INTRODUCTION / Mavic® Customer Service	Page	2	●
MAVIC® WHEELS	Pages	5 - 30	●
Segmentation of the range	Page	5	●
General points	Page	6	●
Cosmos™ wheel	Page	7	●
Speedcity™ wheel	Page	8	●
Crossride™ wheel	Page	9	●
Crossmax™ SL wheel	Page	10	●
Crossmax™ SL Disc wheel	Page	11	●
Crossmax™ XL wheel	Page	12	●
Crossmax™ XL Disc wheel	Page	13	●
Deemax® UST wheel	Page	14	●
Indexation compatibility of the road wheels	Page	15	●
Wheel maintenance	Pages	16	●
- Maintaining the front hub	Pages	17 - 18	●
- Maintaining the rear hub	Pages	19 - 22	●
- Wheel building	Pages	23 - 30	●
MAVIC® RIMS	Pages	31 - 37	●
Segmentation of the range	Page	31	●
General points	Page	32	●
Descriptive chart of what's new	Page	32	●
Wear indicator	Page	33	●
Conditions for using a rim	Pages	33 - 35	●
Special conditions for using a rim for disc brakes	Page	36	●
Special conditions for using and building a UST Tubeless™ rim	Page	37	●
SSC BRAKES, TOOLS AND CUSTOMER SERVICE	Pages	38 - 43	●
SSC brake caliper	Pages	38 - 39	●
Mavic® tools	Pages	40 - 41	●
General procedure for any request for intervention	Page	42	●
Warranty and Mavic® Customer Service / To contact your MSC	Page	43	●

MAVIC® WHEELS

CONTENTS

SEGMENTATION OF THE WHEEL RANGE

TRACK	ROAD			ASPHALT	MTB		
	AERODYNAMIC	MULTI PERFORMANCE	CLASSIC		CROSS COUNTRY RACING	CROSS MOUNTAIN	EXTREME MOUNTAIN BIKE
iO™	COMETE	KSYRIUM SSC SL			CROSSMAX™ SL DISC <small>New</small>	CROSSMAX™ XL DISC <small>New</small>	
COMETE	COSMIC CARBONE SSC				CROSSMAX™ SL <small>New</small>	CROSSMAX™ XL <small>New</small>	
	COSMIC ELITE	KSYRIUM ELITE	COSMOS	SPEEDCITY™ <small>New</small>	CROSSROC DISC CROSSROC CROSSRIDE		

GENERAL POINTS

Dear dealers, we would like to remind you that it is your responsibility to give the customer all wheel instructions and have them fill out the warranty card.

Recommended wheel instructions for the customer :

- Choose a suitable wheel designed for the type of riding you wish to do.
- It is imperative to respect the instructions in this Technical Manual for tire pressure and dimensions (see following charts).
- Respect the appropriate spoke tensions. For more specific information regarding every one of our products, please consult the following pages, the technical manuals from the previous years, or the web site www.tech-mavic.com. Inappropriate spoke tension can generate much stress and quickly cause damage to the rim.
- Clean the rims on a regular basis with the Mavic® abrasive eraser (M40410).
- Remove gravel or metal particles in the brake pads.
- Replace the brake pads when they are worn.
- Do not use a rim if the braking surfaces are worn, if eyelets are missing or in any other case where safety might be compromised. Indeed, a rim is a part that wears out as are brake pads, and need to be replaced if it is worn (sidewall hollowed by wear or cut out, cracked rim);
- Check, or have your rims checked, on a regular basis. If this is not possible, check them at least in the beginning of each season and after intensive use. When checking, look inside (especially under the rim tape) and outside the rim. Look for signs of fatigue, wear, damage to the braking surfaces, or cracks in the walls around the eyelets.

You should also check if you have any doubt about proper spoke tensions or the correct type of tire to use.

Following these recommendations will guarantee longer product life for the wheels, maximum performance and riding enjoyment.

RECOMMENDATIONS FOR MAXIMUM TIRE PRESSURE

CROSS COUNTRY AND CROSS MOUNTAIN*

Tire width		Maximum pressure (bars)	Maximum pressure (PSI)
in "	in mm		
1,00	25	7,70	113
1,20	30	7,00	103
1,50	38	6,00	88
1,75	45	5,20	76
1,85	47	4,80	71
1,90	48	4,70	69
1,95	50	4,50	66
2,00	51	4,30	63
2,10	53	4,00	59
2,20	56	3,70	55
2,50	63	2,70	40

EXTREME MOUNTAIN BIKE*

Tire width		Maximum pressure (bars)	Maximum pressure (PSI)
in "	in mm		
2,00	51	3,80	56
2,10	53	3,70	55
2,20	56	3,50	52
2,30	58	3,30	49
2,40	61	3,20	47
2,50	63	3,00	44
2,60	66	2,80	41
2,70	68	2,70	39
2,80	71	2,50	36

ROAD AND ASPHALT*

Tire width in mm	Maximum pressure (bars)	Maximum pressure (PSI)
19	10,0	146
23	9,5	138
25	9,0	131
28	8,0	117
32	7,0	103
35	6,0	88





* See segmentation chart for types of riding on preceding page.

COSMOS™

Use : **Use only on a road bike.** Any other use (such as on a tandem, cyclo-cross bike, mountain bike...) is strongly inadvisable, and is the sole responsibility of the user, which voids the Mavic® warranty.

WHEEL WEIGHT WITHOUT SKEWER :
FRONT : 750 g.
REAR : 1050 g.

REF. BLACK WHEELS : REF. GRAY WHEELS :
FRONT : M23400 FRONT : M23420
FRONT : M23401 FRONT : M23421
PAIR : M29034 PAIR : M29093

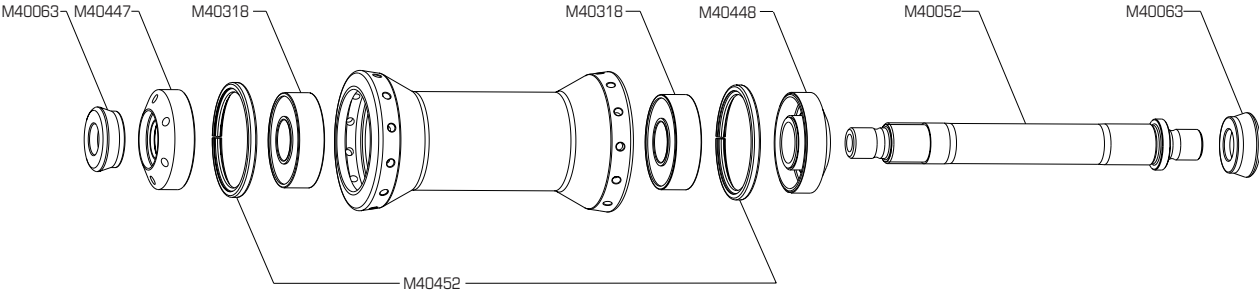
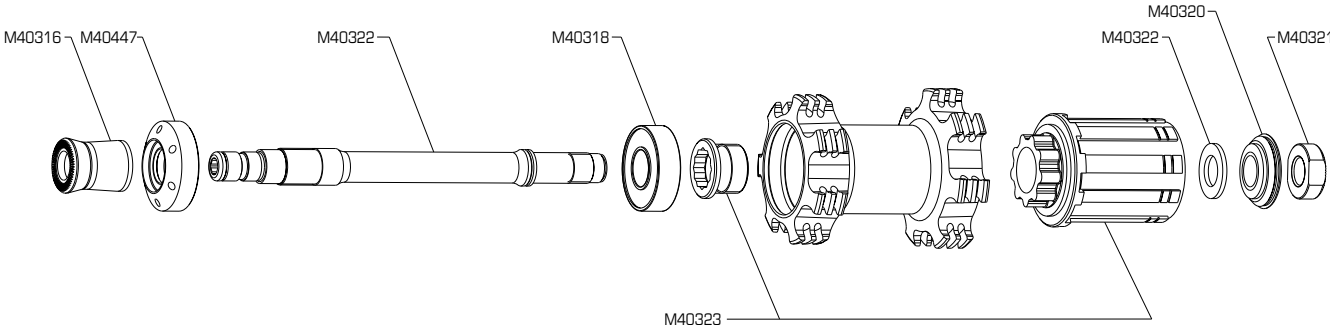
RIM			
COMMERCIAL REFERENCES	VALVE HOLE Ø	RECOMMENDED TIRE WIDTH AND PRESSURE	
Black front : M40531 Black rear : M40532	 Ø : 6,5 mm Length: ≥ 32 mm	 Dimensions: Ø 700 only ETRTO compatible 622 x 13 Recommended tire width: 19 - 28	 Recommended tire pressure: See page 6
Gray front : M40764 Coating  Gray rear : M40765 Coating 			
HUBS			
			
			
MAINTENANCE: Clean with a dry cloth or soap and water. Do not use pressurized water.			
WHEEL BUILDING			
FEATURES :	2.3-2.0 round stainless steel straight pull spokes with ABS type of nipples (self-locking)		LACING PATTERN : Front : radial Rear : 3 cross pattern on both sides
REFERENCE :	Front : M40520, length 287 mm (per 10) Rear FWS : M40523, length 308 mm (per 10) Rear OFW : M40524, length 310 mm (per 10)		TENSION : Front : 80 ± 90 kg Rear free wheel side: 100 - 110 kg
ACCESSORIES			
WHEEL DELIVERED WITH :			
<ul style="list-style-type: none"> • Front quick release skewer : M40350 • Rear quick release skewer: M40351 • Rim tape 		<ul style="list-style-type: none"> • Spoke maintenance wrench: M40123 (with the rear wheel only) • Instructions and warranty card 	
MAINTENANCE			
For all maintenance procedures (removing the front hub, removing the rear hub, replacing spokes or rims), refer to the 2000 technical manual or our website HYPERTEXT LINK http://www.tech-mavic.com .			

WHEELS

SPEEDCITY™

Use : **Use only on the road, on an MTB type of bike or road bike (135 mm rear axle width) equipped with disc brakes or rim brakes.** Any other use (such as on a tandem, cyclo-cross bike, or on cross country terrain...) is strongly inadvisable, and is the sole responsibility of the user, which voids the Mavic® warranty.

WHEEL WEIGHT WITHOUT SKEWER :

FRONT : 865 g.



REAR : 1095 g.

REF. WHEEL :

FRONT : M25400

REAR : M25401

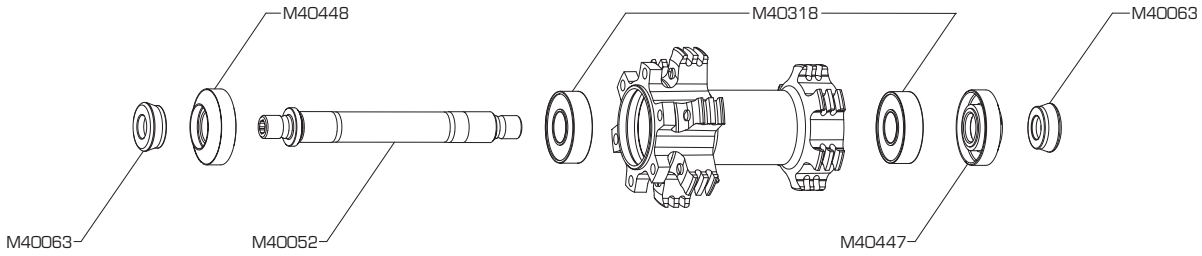
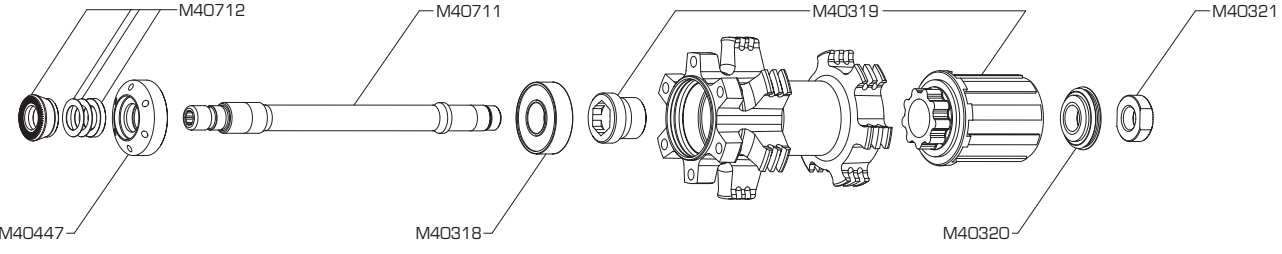

PAIR : M29089

RIM			
COMMERCIAL REFERENCES	VALVE HOLE Ø	RECOMMENDED TIRE WIDTH AND PRESSURE	
Front and rear : M40706 (delivered with screw-on eyelets) Do not use rim tape	 Ø : 6,5 mm Length: ≥ 32 mm	 Dimensions: Ø 700 only ETRTO compatible 622 x 13 Recommended tire width: 19 - 32 (35 with disc brakes).  Recommended tire pressure: See page 6	
HUBS			
 			
MAINTENANCE: Clean with a dry cloth or soap and water. Do not use pressurized water.			
WHEEL BUILDING			
FEATURES :	2.3-2.0 round stainless steel straight pull spokes with ABS (self-locking) type of nipples Screw-on eyelets delivered with the rim	LACING PATTERN :	Front : 2 cross pattern on both sides Rear : 2 cross pattern on both sides
REFERENCE :	Front and rear : M40707, length 299 mm (per 12)	TENSION :	Front disc side: 120 - 130 kg Rear free wheel side: 120 - 130 kg
ACCESSORIES			
WHEEL DELIVERED WITH :			
<ul style="list-style-type: none"> • Front quick release skewer : M40350 • Rear quick release skewer: M40352 		<ul style="list-style-type: none"> • Free play adjustment wrench : M40123 (with rear wheel) • Instructions and warranty card 	
MAINTENANCE			
<ul style="list-style-type: none"> • Replacing the front axle: See page 17 • Replacing the front bearings See page 17 • Replacing the rear axle See page 19 • Replacing the free wheel body See page 20 		<ul style="list-style-type: none"> • Replacing the rear bearings See page 21 • Replacing the spokes See page 23 • Replacing the front rim See page 25 • Replacing the rear rim See page 26 	

CROSSRIDE™

Use : **Use only on an MTB equipped with a rim braking system.** Any other use (such as on a road bike, tandem, cyclo-cross bike, ...) is highly inadvisable, and is the sole responsibility of the user, which voids the Mavic® warranty.

WHEEL WEIGHT WITHOUT SKEWER :
 FRONT : 730 g.
 REAR : 1020 g.
 REF. WHEEL :
 FRONT : M25500
 REAR : M25501
 PAIR : M29095

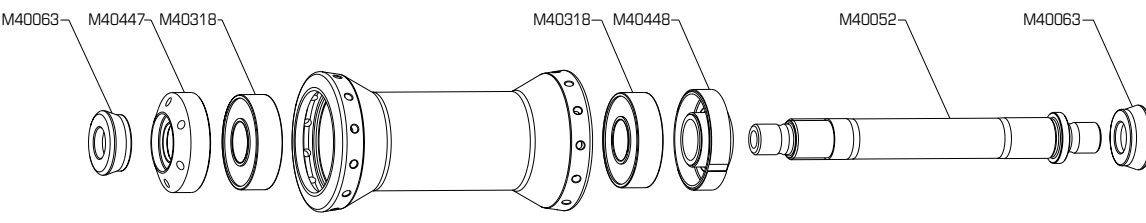
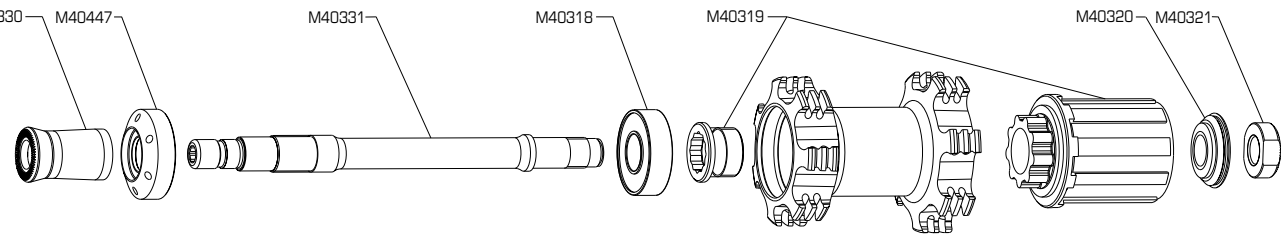
RIM			
COMMERCIAL REFERENCES	VALVE HOLE Ø	RECOMMENDED TIRE WIDTH AND PRESSURE	
Front : M40760 (new reference) Rear : M40761 (new reference)	 Ø : 8,5 mm Length: ≥ 32 mm	 Dimensions: Ø 26" only ETRTO compatible 559 x 17 Recommended tire width: 1,5 - 2,3  Recommended tire pressure: See page 6	
HUBS			
 			
MAINTENANCE: Clean with a dry cloth or soap and water. Do not use pressurized water.			
WHEEL BUILDING			
FEATURES :	2.3-2.0 round stainless steel straight pull spokes with ABS (self-locking) type of nipples in front	LACING PATTERN :	Front : radial Rear : 3 cross pattern on both sides
REFERENCE :	Front : M40208, length 255 mm (per 10) Rear : M40207, length 275 mm (per 10)	TENSION :	Front and rear free wheel side: 90 - 100 kg
ACCESSORIES			
WHEEL DELIVERED WITH :		<ul style="list-style-type: none"> • Front quick release skewer : M40350 • Rear quick release skewer: M40352 • Rim tape • Free play adjustment wrench : M40123 (with rear wheel) • Instructions and warranty card 	
MAINTENANCE			
For all maintenance procedures (removing the front hub, removing the rear hub, replacing spokes or rims), refer to the 2000 technical manual or our website address http://www.tech-mavic.com .			

WHEELS

CROSSMAX™ SL

Use : **Use only on a cross country MTB equipped with a braking system on the rim.** Any other use (such as on a tandem, road bike, cyclo-cross bike,...) is highly inadvisable, and is the sole responsibility of the user, which voids the Mavic® warranty.

WHEEL WEIGHT WITHOUT SKEWER :

FRONT : 650 g.



REAR : 820 g.

REF. WHEEL :

FRONT : M25000

REAR : M25001

PAIR : M29081

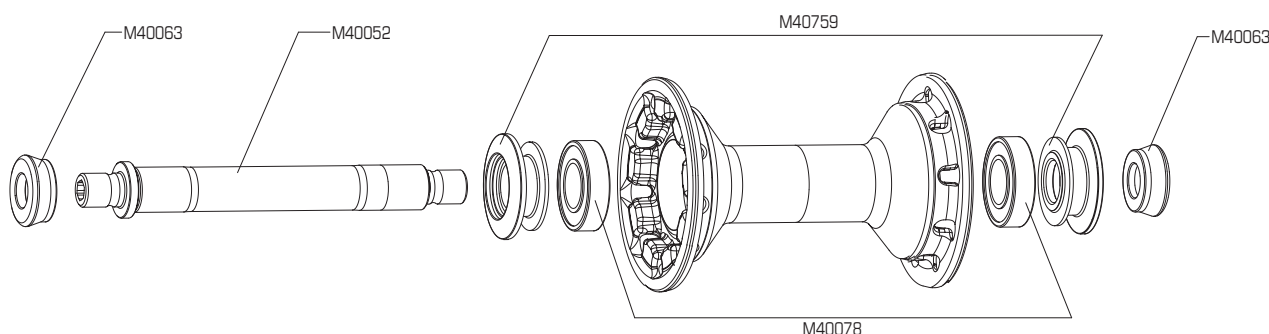
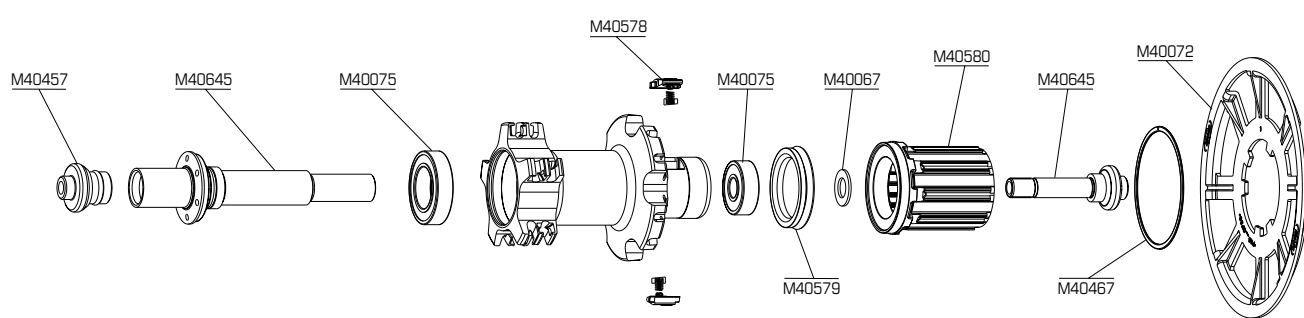
RIM			
COMMERCIAL REFERENCES	VALVE HOLE Ø	RECOMMENDED TIRE WIDTH AND PRESSURE	
Front : M40749 Rear : M40750 Do not use rim tape	 Ø : 6,5 mm UST valve M40495 Presta with Schrader adapter Length: ≥ 32 mm	 Dimensions: Ø 26 ETRTO compatible 559 x 19 Recommended tire width: 1,5 - 2,3	 Recommended tire pressure: See page 6
HUBS			
			
			
MAINTENANCE: Clean with a dry cloth or soap and water. Do not use pressurized water. Caution : The parts on the FTS-L free wheel (pawl assembly, springs, free wheel body) are not compatible with those on the FTS free wheel.			
WHEEL BUILDING			
FEATURES :	Profiled Zicral spokes with anti-rotation system Integrated nipples with brake ring (self-locking)	LACING PATTERN :	Front : radial Rear : Isopulse concept
REFERENCE :	Front : M40751 length 255 mm (per 9) Rear CRL : M40753 length 245 mm (per 10) Rear ORL : M40755 length 274 mm (per 10)	TENSION :	Front : 120 - 130 kg Rear free wheel side: 130 - 140 kg
ACCESSORIES			
WHEEL DELIVERED WITH :			
<ul style="list-style-type: none"> • Front Mavic BX601 quick release skewer: M40140 • Rear Mavic BX601 quick release skewer: M40141 • Chain Disc (with rear wheel) : M40072 • Free play adjustment wrench (with rear wheel) : M40123 		<ul style="list-style-type: none"> • UST valve : M40495 • Spoke tension and maintenance wrenches (with rear wheel) : M40494 • Computer magnet (with front wheel) : M40540 • Instructions and warranty card 	
MAINTENANCE			
<ul style="list-style-type: none"> • Replacing the front axle: See page 17 • Replacing the front bearings: See page 17 • Replacing the rear axle: See page 19 • Replacing the free wheel body: See page 21 		<ul style="list-style-type: none"> • Replacing the rear bearings: See page 22 • Replacing the spokes: See page 23 and 24 • Replacing the front rim: See page 27 • Replacing the rear rim: See page 28 	

CROSSMAX™ SL DISC

Use: **Use only on a cross country MTB equipped with disc brakes.**

Any other use (such as on a tandem, road bike, cyclo-cross bike...) is highly inadvisable and is the sole responsibility of the user, which voids the Mavic® warranty.

WHEEL WEIGHT WITHOUT SKEWER :

FRONT : 770 g.



REAR : 915 g.

REF. WHEEL :

FRONT : M25100

REAR : M25101

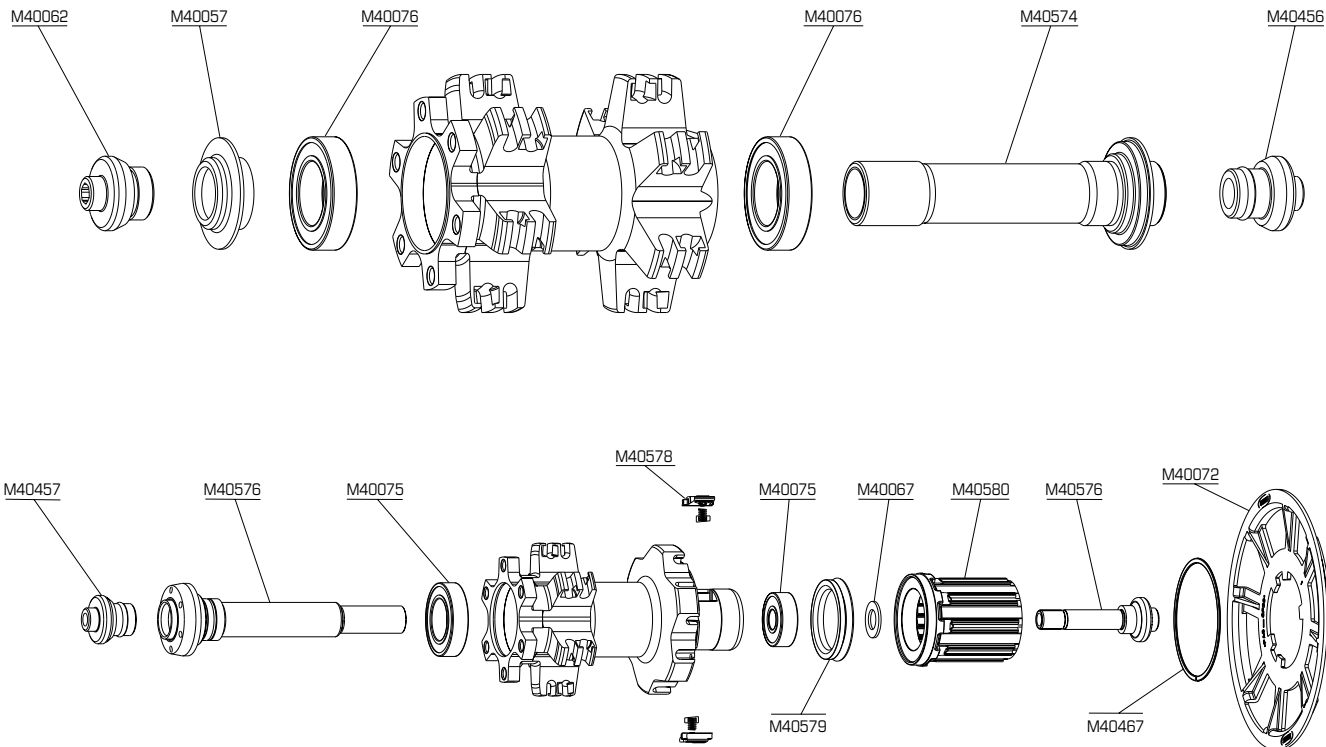

PAIR : M29083

RIM			
COMMERCIAL REFERENCES	VALVE HOLE Ø	RECOMMENDED TIRE WIDTH AND PRESSURE	
Front : M40741 Rear : M40742 Do not use rim tape	 Ø : 6,5 mm UST valve M40495 Presta with Schrader adapter Length: ≥ 32 mm	 Dimensions: Ø 26' ETRTO compatible 559 x 19 Recommended tire width: 1,5 - 2,3  Recommended tire pressure: See page 6	
HUBS			
			
MAINTENANCE: Clean with a dry cloth or soap and water. Do not use pressurized water. Caution : The parts on the FTS-L free wheel (pawl assembly, springs, free wheel body) are not compatible with those on the FTS free wheel.			
WHEEL BUILDING			
FEATURES :	Profiled Zicral spokes with anti-rotation system Integrated nipples with brake ring (self-locking)	LACING PATTERN :	Front : 2 cross pattern on both sides Rear : 2 cross pattern on both sides
REFERENCE :	Front and rear ORL : M40743 length 268 mm (per 12) Rear CRL : M40745 length 250 mm (per 12)	TENSION :	front disc side : 120 - 130 kg Rear disc side: 130 - 140 kg
ACCESSORIES			
WHEEL DELIVERED WITH :			
<ul style="list-style-type: none"> • Front Mavic BX601 quick release skewer: M40140 • Rear Mavic BX601 quick release skewer: M40141 • Chain Disc (with rear wheel) : M40072 • Free play adjustment wrench (with rear wheel) : M40123 		<ul style="list-style-type: none"> • UST valve : M40495 • Spoke tension and maintenance wrenches (with rear wheel) : M40494 • Computer magnet (with front wheel) : M40540 • Instructions and warranty card 	
MAINTENANCE			
<ul style="list-style-type: none"> • Replacing the front axle: See page 17 • Replacing the front bearings See page 17 • Replacing the rear axle See page 19 • Replacing the free wheel body See page 21 		<ul style="list-style-type: none"> • Replacing the rear bearings See page 22 • Replacing the spokes See page 24 • Replacing the front rim See page 29 • Replacing the rear rim See page 30 	

CROSSMAX™ XL

Use : **Use only on an MTB equipped with a rim braking system.** Any other use (such as on a tandem, road bike, cyclo-cross bike...) is highly inadvisable, and is the sole responsibility of the user, which voids the Mavic® warranty.

WHEEL WEIGHT WITHOUT SKEWER :
 FRONT : 730 g.
 REAR : 885 g.
 REF. WHEEL :
 FRONT : M25200
 REAR : M25201
 PAIR : M29085

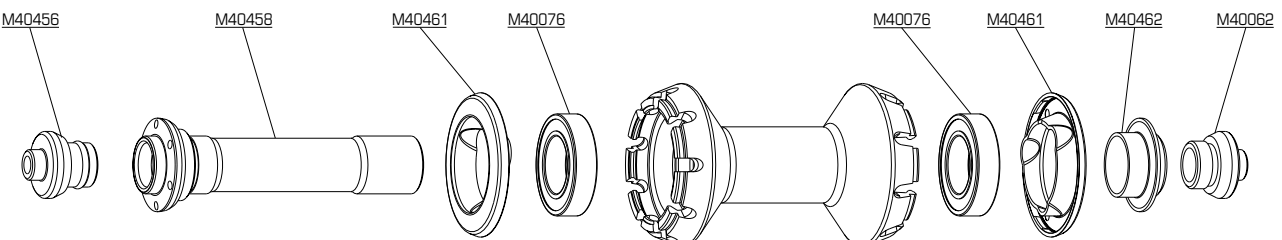
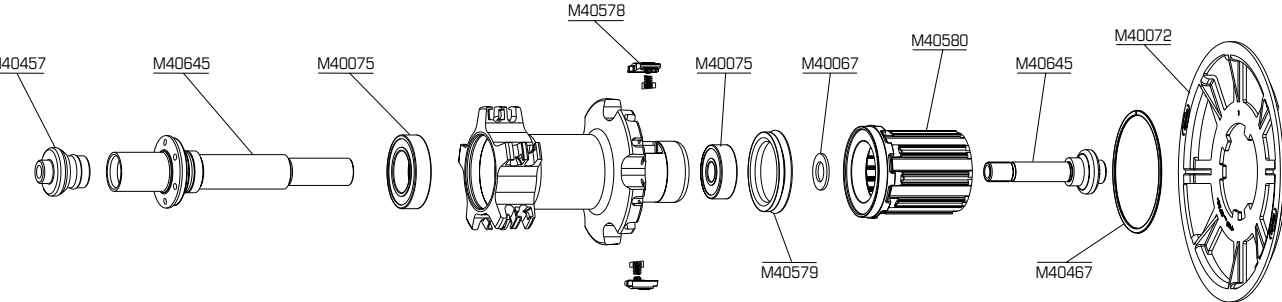
RIM			
COMMERCIAL REFERENCES	VALVE HOLE Ø	RECOMMENDED TIRE WIDTH AND PRESSURE	
Front : M40725 Rear : M40726 Do not use rim tape	 Ø : 6,5 mm UST valve M40495 Presta with Schrader adapter Length: ≥ 32 mm	 Dimensions: Ø 26' ETRTO compatible 559 x 19 Recommended tire width: 1,5 - 2,3  Recommended tire pressure: See page 6	
HUBS			
 			
MAINTENANCE: Clean with a dry cloth or soap and water. Do not use pressurized water. Caution : The parts on the FTS-L free wheel (pawl assembly, springs, free wheel body) are not compatible with those on the FTS free wheel.			
WHEEL BUILDING			
FEATURES :	Round Zicral spokes with anti-rotation system. Integrated nipples with brake ring (self-locking)	LACING PATTERN :	Front : radial Rear : Isopulse concept
REFERENCE :	Front : M40727 length 255 mm (per 9) Rear CRL : M40729 length 245 mm (per 10) Rear ORL : M40731 length 274 mm (per 10)	TENSION :	Front : 120 - 130 kg Rear free wheel side : 130 - 140 kg
ACCESSORIES			
WHEEL DELIVERED WITH :			
<ul style="list-style-type: none"> • Front Mavic BX601 quick release skewer: M40140 • Rear Mavic BX601 quick release skewer: M40141 • Chain Disc (with rear wheel) : M40072 • Free play adjustment wrench (with rear wheel) : M40123 		<ul style="list-style-type: none"> • UST valve : M40495 • Spoke tension and maintenance wrenches (with rear wheel) : M40494 • Instructions and warranty card 	
MAINTENANCE			
<ul style="list-style-type: none"> • Replacing the front axle: See page 17 • Replacing the front bearings: See page 17 • Replacing the rear axle: See page 19 • Replacing the free wheel body: See page 21 		<ul style="list-style-type: none"> • Replacing the rear bearings: See page 22 • Replacing the spokes: See page 24 • Replacing the front rim: See page 27 • Replacing the rear rim: See page 28 	

CROSSMAX™ XL DISC

Use : **Use only on a cross country MTB equipped with disc brakes.**

Any other use (such as on a tandem, road bike, cyclo-cross bike...) is highly inadvisable, and is the sole responsibility of the user, which voids the Mavic® warranty.

WHEEL WEIGHT WITHOUT SKEWER :

FRONT : 860 g.



REAR : 945 g.

REF. WHEEL :

FRONT : M25300

REAR : M25301

PAIR : M29087

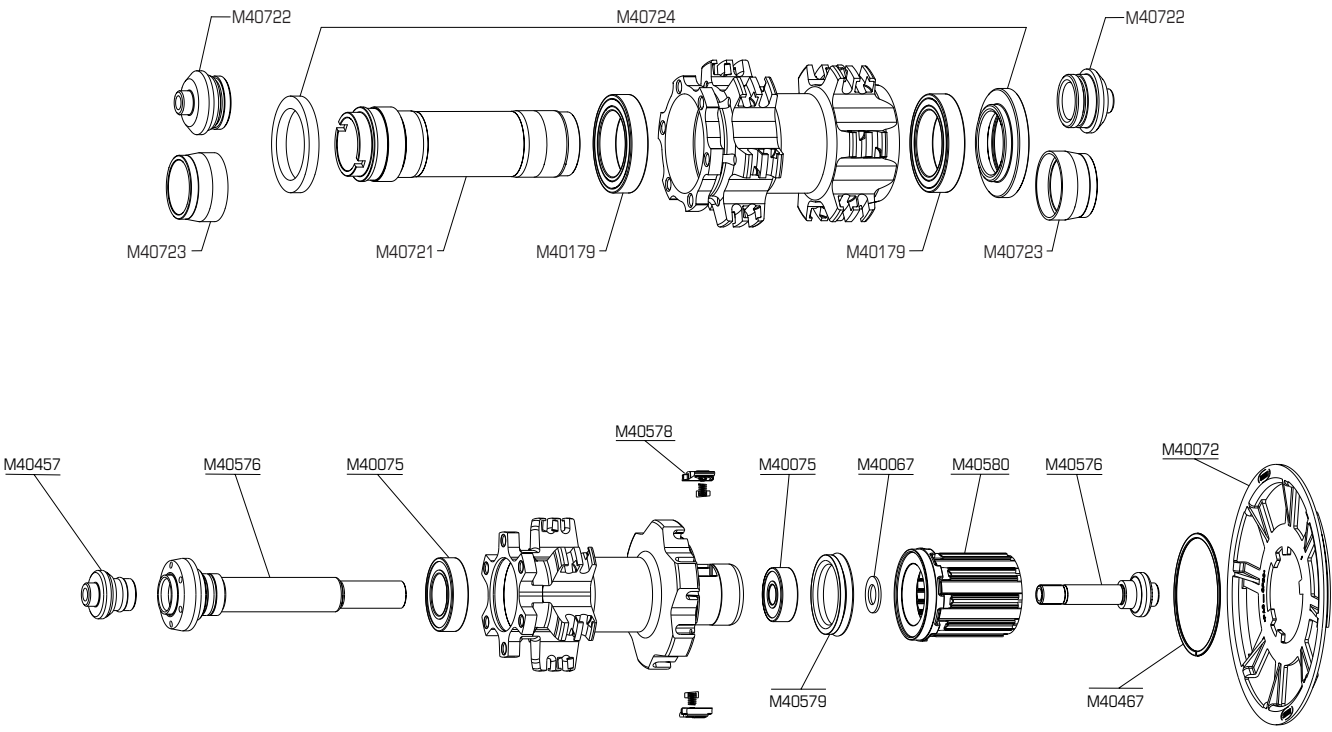
RIM			
COMMERCIAL REFERENCES	VALVE HOLE Ø	RECOMMENDED TIRE WIDTH AND PRESSURE	
Front : M40713 Rear : M40714 Do not use rim tape	 Ø : 6,5 mm UST valve M40495 Presta with Schrader adapter Length: ≥ 32 mm	 Dimensions: Ø 26' ETRTO compatible 559 x 19 Recommended tire width: 1,5 - 2,3  Recommended tire pressure: See page 6	
HUBS			
			
MAINTENANCE: Clean with a dry cloth or soap and water. Do not use pressurized water. Caution : The parts on the FTS-L free wheel (pawl assembly, springs, free wheel body) are not compatible with those on the FTS free wheel.			
WHEEL BUILDING			
FEATURES :	Round Zicral spokes with anti-rotation system. Integrated nipples with brake ring (self-locking)	LACING PATTERN :	Front : 2 cross pattern on both sides Rear : 2 cross pattern on both sides
REFERENCE :	Front and rear ORL : M40715 length 268 mm (per 12) Rear CRL : M40717 length 250 mm (per 12)	TENSION :	Front disc side : 120 - 130 kg Rear free wheel side : 130 - 140 kg
ACCESSORIES			
WHEEL DELIVERED WITH :			
<ul style="list-style-type: none"> • Front Mavic BX601 quick release skewer: M40140 • Rear Mavic BX601 quick release skewer: M40141 • 20 mm axle adapters : M40723 • Chain Disc (with rear wheel) : M40072 		<ul style="list-style-type: none"> • Free play adjustment wrench (with rear wheel) : M40123 • UST valve M40495 • Spoke tension and maintenance wrenches (with rear wheel) : M40494 • Instructions and warranty card 	
MAINTENANCE			
<ul style="list-style-type: none"> • Replacing the front axle: See page 18 • Replacing the front bearings See page 18 • Replacing the rear axle See page 19 • Replacing the free wheel body See page 21 		<ul style="list-style-type: none"> • Replacing the rear bearings See page 22 • Replacing the spokes See page 24 • Replacing the front rim See page 29 • Replacing the rear rim See page 30 	

WHEELS

DEEMAX® UST

Use : **Use only on an MTB equipped with disc brakes.** Any other use (such as on a tandem, road bike, cyclo-cross bike,...) is highly inadvisable, and is the sole responsibility of the user, which voids the Mavic® warranty.

WHEEL WEIGHT WITHOUT SKEWER :

FRONT : 1075 g.



REAR : 1235 g.

REF. WHEEL :

FRONT : M24800

REAR : M24801

PAIR : M29091

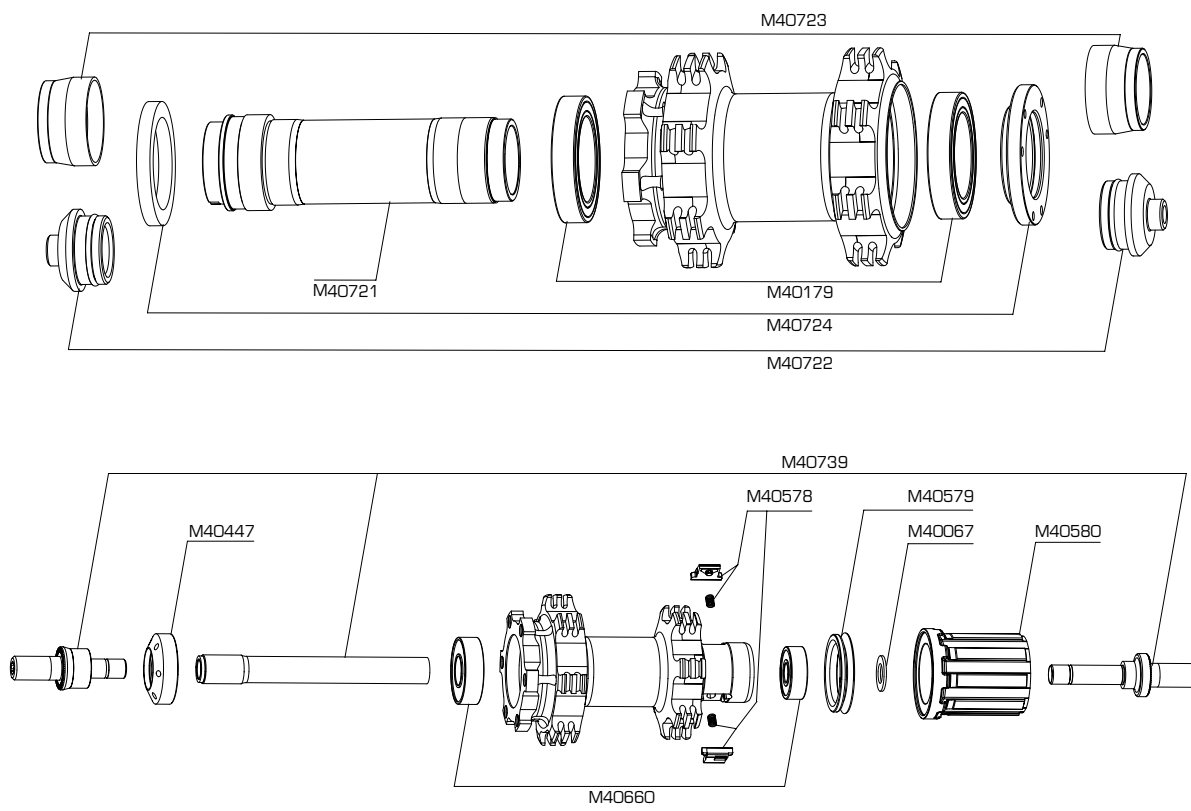
RIM			
COMMERCIAL REFERENCES	VALVE HOLE Ø	RECOMMENDED TIRE WIDTH AND PRESSURE	
Front and rear : M40734 Delivered with screw-on eyelets Do not use rim tape	 Ø : 6,5 mm UST valve M40495 Presta with Schrader adapter Length: ≥ 32 mm	 Dimensions: Ø 26' ETRTO compatible 559 x 23 Recommended tire width: 2,00 - 2,8	 Recommended tire pressure: See page 6
HUBS			
			
MAINTENANCE: Clean with a dry cloth or soap and water. Do not use pressurized water. Caution : The parts on the FTS-L free wheel (pawl assembly, springs, free wheel body) are not compatible with those on the FTS free wheel.			
WHEEL BUILDING			
FEATURES :	2.3 - 2.0 straight pull stainless steel spokes with ABS type of nipples (self-locking) Screw-on eyelets delivered with the rim	LACING PATTERN :	Front : radial Rear: Isopulse concept
REFERENCE :	Front and rear : M40735 length 276 mm (per 14)	TENSION :	Front disc side : 120 - 130 kg Rear free wheel side : 120 - 130 kg
ACCESSORIES			
WHEEL DELIVERED WITH :			
<ul style="list-style-type: none"> • 9 mm axle adapters : M40722 • 20 mm axle adapters : M40723 • UST valve M40495 		<ul style="list-style-type: none"> • Free play adjustment wrench : M40123 (with rear wheel) • Instructions and warranty card • Axle nuts (rear wheel) : M40740 	
MAINTENANCE			
<ul style="list-style-type: none"> • Replacing the front axle See page 18 • Replacing the front bearings See page 18 • Replacing the rear axle See page 20 • Replacing the free wheel body See page 21 		<ul style="list-style-type: none"> • Replacing the rear bearings See page 22 • Replacing the spokes See page 23 • Replacing the front rim See page 25 • Replacing the rear rim See page 26 	

INDEXATION COMPATIBILITY OF ROAD WHEELS

To offer total indexation compatibility with the different cassettes and derailleurs on the market, Mavic® has developed a new FTS L free wheel design that allows the wheels that have integrated this design to accommodate:

- The 8 or 9 speed HG cassettes, on the M10 wheels, for a Shimano 8 or 9 speed compatibility, and Mektronic (9 V).
- The Mavic® M10 cassettes, on the M10 wheels, for a Campagnolo 8, 9 or 10 speed compatibility, and Mektronic (9 V).
- The ED 9 or 10 speed cassettes, on the ED10 wheels, for a Campagnolo 9 or 10 speed compatibility.

The wheels that are not equipped with the FTS-L free wheel body are available in the M9 / M10 version and accommodate the Mavic® M10 or Shimano 8 or 9 speed cassettes.

To synthesize this information and know the different possibilities available to you depending on your wheel version, we offer the following recap chart:

Indexation		Mavic® Mektronic		Shimano			Campagnolo					
Number of speeds		9		8	9		8	9			10	
Version of Mavic® wheel		M9 or M10		M9 or M10			M9 or M10			ED10	M10	ED10
Type of cassette		HG9	M10	HG8	HG9	M10	M10	M10	HG9	ED9	M10	ED10
Positioning spacer*		With		With			Without					
Spacer	Reference	Origin	M40409	Origin	Origin	M40409	M40182	M40181	M40253	Origin	M40573	Origin
	Color		Gray			Gray	Alu	Yellow	Gray		Black	

* The positioning spacer is supplied with the M9 / M10 wheels and the gray spacer kit M40409. It must be :

- Kept for mounting with a Mavic® Mektronic or Shimano transmission,
- Removed for mounting with a Campagnolo transmission.

The Mavic® M10 cassette is originally designed for Campagnolo 9 speed compatibility (yellow spacers M40181) or 10 speed (black spacers M40573). These 2 sets of spacers are delivered with the M10 Kit.

However, for this cassette to be compatible with a Mavic® Mektronic transmission or Shimano 9 speed, you have to order the gray spacer kit M40409 separately.

Also, for compatibility with a Campagnolo 8 speed, you have to order the alu spacers M40182 separately.

It is also possible to mount a Shimano cassette for compatibility with a Campagnolo derailleur. You just need to use a Mavic® M9 / M10 wheel, a Shimano cassette such as the Ultegra or Dura Ace and the Mavic® HG/CC9 spacer kit (M40253).

WHICH WHEEL FOR WHICH COMPATIBILITY:

Generally speaking, the wheels with the FTS-L system, are offered in the M10 and ED10 version.

The other wheels exist only in the M9 / M10 version.

The following is a recap of the wheels in the 2003 range:

One M9 / M10 version: Cosmos, Cosmic® Elite

The choice of M10 : Ksyrium Elite, Ksyrium SSC SL, Cosmic® Carbone SSC, Comète road

NOTE : For wheels with the Zicral spokes (Ksyrium™ SSC SL, but also Crossmax™ SL, Crossmax™ SL Disc, Crossmax™ XL, Crossmax™ XL Disc), you absolutely must keep the Chain Disc initially mounted on the free wheel body (remove the rubber shipping band that holds the Chain Disc), which will protect the aluminum spokes in case the chain passes between the last cog and the spokes. Then depending on the option chosen, you will install a spacer if needed and then the corresponding cassette.

SPECIAL CASE FOR THE SPEEDCITY™ WHEEL

This wheel has been designed for use on the road but on MTB type of frames, with a 135 mm rear axle width. As with all MTB wheels, it is only compatible with the Shimano type of cassettes.

WHEEL MAINTENANCE

Reminder of the Mavic® warranty

Prior to any repair of a Mavic® wheel (or on any other Mavic product), please note that it has a warranty against manufacturing or material defects for a period of two years from the date of original purchase (see Mavic warranty page 42).

This means that :

- during the warranty period, and when it definitely applies to the warranty (first contact your MSC), you must return the Mavic® wheel (or any other Mavic® product) directly to your MSC following the procedure explained on page 42 to get the Mavic® warranty.

However, if you decide to repair the wheel by yourself (or any other Mavic® product), your customer will lose the Mavic warranty.

- after the warranty period and in case of repair, we advise you to refer to the following pages to intervene on the Mavic® wheel. If replacing the rim, please note the new serial number of the rim on the original warranty card and the date of intervention.

Only this procedure will allow your customer to get the Mavic® warranty on the replaced rim.

Repairs

The following pages will help you to maintain the wheels in the 2003 range and are organized as follows :

1. Maintaining the front hubs.....	Page 17
1.1. Front axle and bearings on the Crossmax™ SL and Speedcity™	Page 17
1.2. Front axle and bearings on the Crossmax™ SL Disc and Crossmax™ XL.....	Page 17
1.3. Axle and bearings on the Crossmax XL™ Disc and Deemax® UST	Page 18
2. Maintaining the rear hubs	Page 18
2.1. Rear axle	Page 18
2.1.1. Speedcity™	Page 18
2.1.2. Crossmax™ SL, Crossmax™ SL Disc, Crossmax™ XL and Crossmax™ XL Disc.....	Page 19
2.1.3. Deemax® UST	Page 20
2.2. Free wheel body.....	Page 20
2.2.1. Speedcity™	Page 20
2.2.2. Crossmax™ SL, Crossmax™ SL Disc, Crossmax™ XL, Crossmax™ XL Disc and Deemax® UST.....	Page 21
2.3. Rear bearings.....	Page 21
2.3.1. Speedcity™	Page 21
2.3.2. Crossmax™ SL, Crossmax™ SL Disc, Crossmax™ XL, Crossmax™ XL Disc.....	Page 22
2.3.3. Deemax® UST	Page 22
3. Wheel building	Page 23
3.1. Replacing spokes	Page 23
3.1.1. Speedcity™ and Deemax® UST	Page 23
3.1.2. Front Crossmax™ SL	Page 23
3.1.3. Rear Crossmax™ SL, Crossmax™ SL Disc, Crossmax™ XL and Crossmax™ XL Disc.....	Page 24
3.2. Replacing the rim	Page 25
3.2.1. Speedcity™ and Deemax® UST	Page 25
3.2.1.1. Front rim.....	Page 25
3.2.1.2. Rear rim	Page 26
3.2.2. Crossmax™ SL and Crossmax™ XL	Page 27
3.2.2.1. Front rim on the Crossmax™ SL	Page 27
3.2.2.2. Front rim on the Crossmax™ XL	Page 27
3.2.2.3. Rear rim on the Crossmax™ SL and Crossmax™ XL	Page 28
3.2.3. Crossmax™ SL Disc and Crossmax™ XL Disc	Page 29
3.2.3.1. Front rim	Page 29
3.2.3.2. Rear rim	Page 30

Before any operation, we recommend removing:

- the wheel from the bike by releasing the quick release skewer.
- the skewer, the tire ;
- the cassette and chain disc (if necessary) for the rear wheel.

1. MAINTAINING THE FRONT HUBS

1.1. FRONT BEARING AND AXLE KIT FOR THE CROSSMAX™ SL AND SPEEDCITY™ WHEELS

Tools needed:

- 1 x 5 mm Allen wrench
- 1 hub wrench M40123
- Bearing pullers M40120 (Crossmax™ SL) or M40373 (Speedcity™)

- 1 Remove the fork support on the adjustment nut side. This is press fit on the end of the axle.
- 2 Insert a 5 mm Allen wrench on the opposite side of the adjustment nut and loosen the adjustment nut using the hub wrench M40123.
- 3 Remove the axle.
- 4 Drive out the bearings with the bearing pullers M40120 (long rod, see photo page 40) ;
- 5 Mount the new bearings using the bearing pullers M40120 (Crossmax™ SL) or M40373 (Speedcity™) ;
- 6 Mount the axle: insert the 5 mm Allen wrench in the axle and tighten the adjustment nut using the hub wrench M40123.
- 7 Clip the fork support back on ;
- 8 Put the wheel back in place on the fork, tighten the quick release skewer and adjust the bearing free play using the hub wrench M40123.

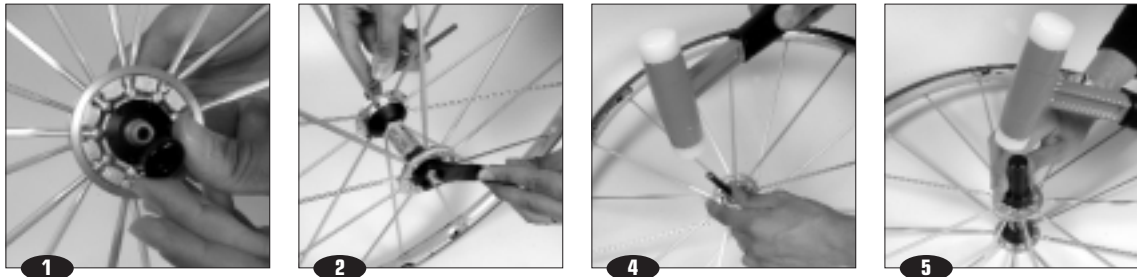

For the front Crossmax™ SL wheel, NEVER replace the bearings on a bare hub. Always replace them when the hub is built into a wheel.

1.2. FRONT BEARING AND AXLE KIT ON THE CROSSMAX™ SL DISC AND CROSSMAX™ XL WHEELS

Tools needed:

- 1 x 5 mm Allen wrench
- 1 x 10 mm Allen wrench
- 1 hub wrench M40123
- Bearing pullers M40119

- 1 Loosen the free play adjustment nut one turn using the hub wrench M40123 by holding the other end of the axle with a 5 mm Allen wrench, to avoid damaging the bearings when mounting the axle again.
- 2 Remove the fork support on the adjustment nut side. This is press fit on the end of the axle.
- 3 Insert a 5 mm Allen wrench on the opposite side of the adjustment nut and the 10 mm Allen wrench on the adjustment nut side.
- 4 Loosen the axle end screw.
- 5 Remove the axle.
- 6 Drive out the bearings with the bearing pullers M40119 (long rod, see page 40) ;
- 7 Mount the new bearings using the bearing pullers M40119 ;
- 8 Replace the axle and mount it again using both the 5 and 10 mm Allen wrenches (torque: 6 - 8 Nm) ;
- 9 Clip the fork support back on.
- 10 Put the wheel back in place on the fork, tighten the quick release skewer, and adjust the bearing free play using the hub wrench M40123.

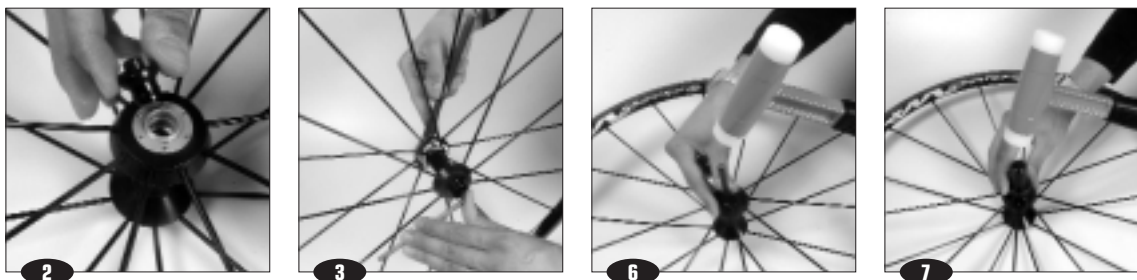



1.3. FRONT BEARING AND AXLE KIT ON THE CROSSMAX™ XL DISC AND DEEMAX® UST WHEELS

Tools needed:

- 1 screwdriver
- 1 hub wrench M40123
- Bearing pullers M40119 (part D, see photo page 40)
- Bearing pullers M40218

- 1 Remove the fork support (9 or 20 mm) from both sides of the axle. These are press fit (9 mm) or sleeved (20 mm) on the end of the axle (for the 9 mm fork supports, you can push them from inside the hub using a quick release skewer, for example).
- 2 Use the screwdriver to hold the axle by inserting it into the slots on the opposite side of the adjustment nut. Loosen the adjustment nut with the hub wrench M40123 (only use the very tips of the wrench).
- 3 Remove the axle
- 4 Drive out the bearings with the bearing pullers M40119 (long rod, see photo page 40) ;
- 5 Mount the new bearings using the bearing pullers M40218 ;
- 6 Mount the axle : tighten the adjustment nut with the hub wrench M40123 while holding the axle on the other side with a screwdriver.
- 7 Mount the 9 mm or 20 mm fork support. To ensure that the 9 mm fork support is properly mounted, Mavic® recommends that you oil the rubber O-Ring on the fork support and mount it using a rotating movement.
- 8 Mount the wheel on the fork, tighten the quick release skewer (if necessary) and adjust the bearing free play using the hub wrench M40123.

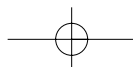
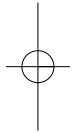
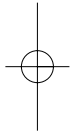
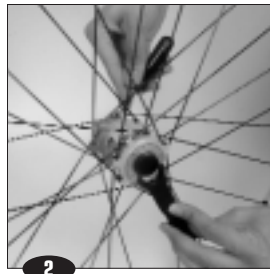
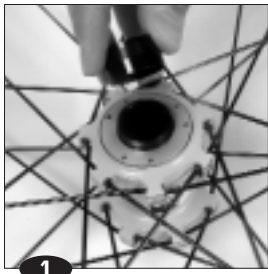

2. MAINTAINING THE REAR HUBS

2.1. REAR AXLE

2.1.1. REAR AXLE ON THE SPEEDCITY™ WHEEL

Tools needed:

- 1 x 5 mm Allen wrench
- 1 x 16 mm flat wrench
- 1 hub wrench M40123

- 1 Loosen the free play adjustment nut one turn using the hub wrench M40123 while holding the other end of the axle with the 5 mm Allen wrench, to avoid damaging the bearings when mounting the axle again.
- 2 Insert the 5 mm Allen wrench in the axle on the opposite side of the free wheel and the 16 mm flat wrench on the nut on the free wheel side.
- 3 Loosen the nut on the free wheel side and remove the axle.
- 4 Replace the axle, put the washer on, and then the joint ring. Tighten the nut with the 16 mm flat wrench, while holding the axle with the 5 mm Allen wrench opposite the free wheel side (torque 6 - 8 Nm) ;
- 5 Mount the wheel on the frame, tighten the quick release skewer, and adjust the bearing free play with the hub wrench M40123.

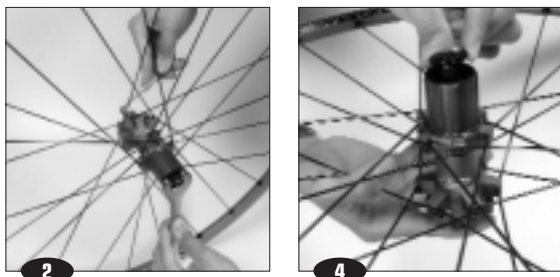

NB : If you do not wish to separate the adjustment nut from the axle, unclip the axle end screw, remove the adjustment wedges and the support washer, hold the axle with the 5 mm Allen wrench, and loosen the adjustment nut using the hub wrench M40123. Follow the same procedure for mounting again by tightening it only one turn: finish tightening it when adjusting the bearing free play (wheel in the frame).

Modification of the axle offset to align the brake disc with its caliper

Originally, 2 ten millimeter adjustment wedges are mounted on the axle, opposite the free wheel side, between the fork support and support washer (parts M40712 described on page 8). To make sure the brake disc is perfectly aligned with the caliper attached to the frame, it could be useful to remove or add 1 or 2 adjustment wedges, removing the fork support beforehand.

This offset adjustment is only made possible (and eventually useful) by the design of this particular hub and the parts used for this.

2.1.2. REAR AXLE ON THE CROSSMAX™ SL, CROSSMAX™ SL DISC, CROSSMAX™ XL AND CROSSMAX™ XL DISC WHEELS

Tools needed:

- 1 x 5 mm Allen wrench
- 1 x 10 mm Allen wrench
- 1 hub wrench M40123

- 1 Loosen the free play adjustment nut one turn using the hub wrench M40123 while holding the other end of the axle with the 5 mm Allen wrench, to avoid damaging the bearings when mounting the axle again.
- 2 Remove the axle end screw opposite the free wheel side.
- 3 Insert the 5 mm Allen wrench into the end of the axle on the free wheel side and the 10 mm Allen wrench in the end of the axle on the side opposite the free wheel, and loosen the axle end screw.
- 4 Remove the axle by pushing on the axle end screw to extract it on the side opposite the free wheel.

Caution : From this moment, the free wheel body is no longer held in place and can easily come apart.

- 5 Replace the axle and mount it using both the 5 and 10 mm Allen wrenches (torque 6 - 8 Nm).
- 6 Put the axle end screw back in place.
- 7 Mount the wheel on the frame, tighten the quick release skewer, and adjust the bearing free play with the hub wrench M40123.





2.1.3. REAR AXLE ON THE DEEMAX® UST WHEEL

Tools needed:

- 2 x 5 mm Allen wrenches
- 1 hub wrench M40123

- 1 Loosen the free play adjustment nut one turn using the hub wrench M40123 while holding the other end of the axle with the 5 mm Allen wrench, to avoid damaging the bearings when mounting the axle.
- 2 Insert a 5 mm Allen wrench into both ends of the axle.
- 3 Loosen the axle end screw with 2 x 5 mm Allen wrenches.

The axle is made up of 3 parts, so that when doing this procedure, it is possible that the fork support on the adjustment nut side unscrews, which prevents the removal of the axle. If this is the case, repeat step # 4 while inserting a 5 mm Allen wrench in place of the fork support.

- 4 Remove the axle by pushing on the axle end screw to extract it on the side opposite the free wheel.

Caution : From this moment on, the free wheel body is no longer held in place and can easily come apart.

- 5 Replace the axle and mount it using 2 x 5 mm Allen wrenches (torque : 6 - 8 Nm).
- 6 Mount the wheel on the frame, tighten the nuts and adjust the bearing free play with the hub wrench M40123.

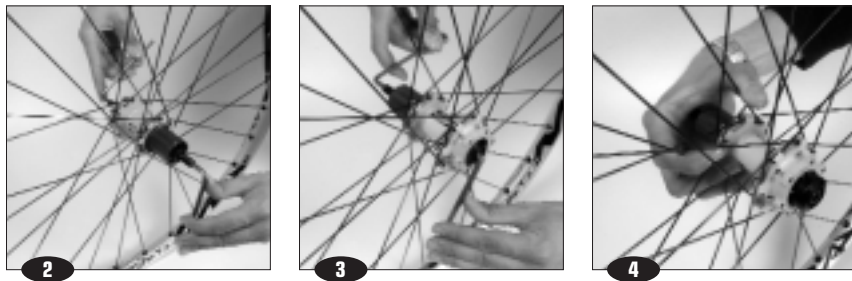

2.2. FREE WHEEL BODY

2.2.1. FREE WHEEL BODY ON THE SPEEDCITY™ WHEEL

Tools needed:

- 1 x 5 mm Allen wrench
- 1 x 12 mm Allen wrench
- 1 x 16 mm flat wrench
- Bearing pullers M40373
- Bearing pullers M40119 (part D, see page 40)
- 1 hub wrench M40123

- 1 Disassemble the axle kit and bearing kit by following procedures 2.1.1 and 2.3.1.
- 2 Insert the 12 mm Allen wrench from the side opposite the free wheel, through the guide ring supplied with the kit M40373 and loosen the free wheel body attachment nut ;
- 3 After cleaning the hub body, mount the free wheel body by tightening the attachment nut using a 12 mm Allen wrench and the guide ring supplied with the kit M40373. Torque: 45 - 60 Nm.
- 4 Mount the bearing kit and the axle kit as indicated in procedures 2.1.1 and 2.3.1.
- 5 Mount the wheel on the frame, tighten the quick release skewer and adjust the bearing free play using the hub wrench M40123.

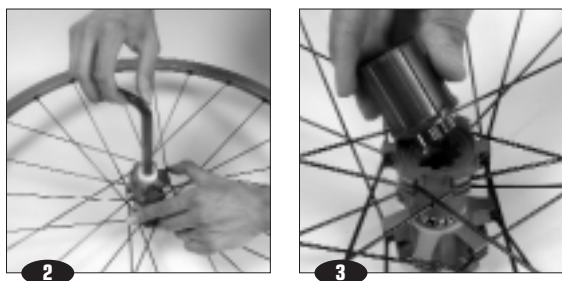



2.2.2. FTS-L FREE WHEEL BODY ON THE CROSSMAX™ SL, CROSSMAX™ SL DISC, CROSSMAX™ XL, CROSSMAX™ XL DISC AND DEEMAX® UST WHEELS

Tools needed:

- 1 x 5 mm Allen wrench
- 1 x 10 mm Allen wrench
- Mavic® mineral oil M40122

- 1 Disassemble the complete axle kit by following procedure 2.1.2. (2.1.3. for the Deemax® UST).
- 2 Remove the FTS-L free wheel body :
 - 2.1 Pull the FTS-L free wheel body towards the exterior until it doesn't move any farther (about 4 mm).
 - 2.2 Turn the FTS-L free wheel body and pull it carefully off the hub axle while holding the pawls and springs.

Caution : When you disassemble the FTS-L free wheel body, the pawls are no longer supported. The pawls and springs may pop out. This can be prevented by holding the pawls with your hand.

- 3 Remove the spring/pawl assembly and clean it.
- 4 Replace the FTS-L free wheel body kit and lip seal (install the new one against the nose of the hub, the lip toward the outside). Lubricate the lip seal with Mavic® mineral oil M40122.
- 5 Lubricate the inside of the FTS-L free wheel body kit in the cog area (10 - 20 drops of Mavic® mineral oil M40122).
- 6 Mount the spring/pawl assembly (spring fits over the pins of the centering stud on the pawl assembly). Put the springs and then pawl assembly in place, the round side touching the axle. Then pivot the pawl assembly.
- 7 Mount the FTS-L free wheel body kit :
 - 7.1 Make sure the spacer washer M40067 (available in 10 piece kit) is well placed inside the FTS-L free wheel body :
The absence of this spacer washer prevents the free wheel from working properly.
 - 7.2 Mount the FTS-L free wheel body kit holding the pawl assembly in your hand in the low position (springs compressed) ;
- 8 Mount the axle end screw and axle kit as indicated in procedures 2.1.2. (2.1.3. for the Deemax® UST). Mount the wheel on the frame, tighten the quick release skewer, and adjust the bearing free play.

It is useful to lubricate the free wheel body 1 - 2 times a year or whenever it becomes noisy. For this, follow the above procedure.

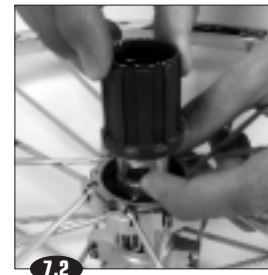
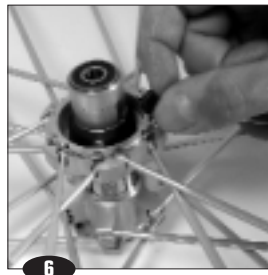
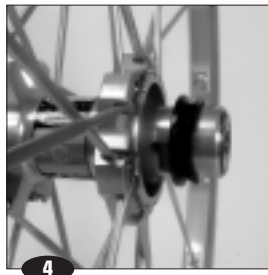
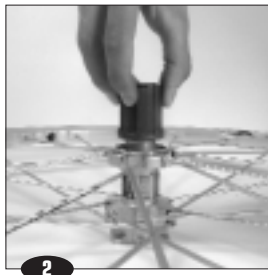

2.3. REAR BEARINGS

2.3.1. REAR BEARINGS ON THE SPEEDCITY™ WHEEL

Tools needed:

- 1 x 5 mm Allen wrench
- 1 x 16 mm flat wrench
- Bearing pullers M40373
- Bearing pullers M40119 (part D, see photo page 40)
- 1 hub wrench M40123

- 1 Remove the complete axle kit following procedure 2.1.1.
- 2 Drive out the bearing from the hub body using the bearing pullers M40119 (long shaft, see photo page 40)
- 3 After cleaning the hub body, mount the new bearing using the bearing pullers M40373 ;
- 4 Mount the axle kit and free wheel body following procedure 2.1.1.
- 5 Mount the wheel on the frame, tighten the quick release skewer, and adjust the bearing free play with the hub wrench M40123.





2.3.2. REAR BEARINGS ON THE CROSSMAX™ SL, CROSSMAX™ SL DISC, CROSSMAX™ XL AND CROSSMAX™ XL DISC WHEELS

Tools needed:

- 1 x 5 mm Allen wrench
- 1 x 10 mm Allen wrench
- 1 hub wrench M40123
- Bearing pullers M40119

- 1 Disassemble the complete axle kit and the free wheel body kit following procedures 2.1.2. and 2.2.2.
- 2 Drive out the bearing on the free wheel side and then the bearing on the side opposite the free wheel using the bearing pullers M40119 (long shaft, see photo page 40).
- 3 After cleaning the body, mount the new bearings using the bearing pullers M40119.
- 4 Mount the free wheel body and axle kit following procedures 2.1.2. and 2.2.2.
- 5 Mount the wheel on the frame, tighten the quick release skewer, and adjust the bearing free play with the hub wrench M40123.

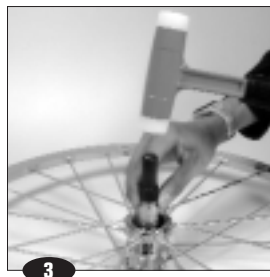

2.3.3. REAR BEARINGS ON THE DEEMAX® UST WHEEL

Tools needed:

- 2 x 5 mm Allen wrenches
- 1 hub wrench M40123
- Bearing pullers M40373
- Bearing pullers M40119 (part D, see photo page 40)

- 1 Disassemble the complete axle kit and free wheel body kit following procedures 2.1.3. and 2.2.2.
- 2 Drive out the bearings on the free wheel side and on the side opposite the free wheel using the bearing pullers M40119 (long shaft, see photo page 40).
- 3 After cleaning the body, mount the new bearings:
 - 3.1 Free wheel side using the bearing pullers M40119.
 - 3.2 Side opposite the free wheel using the bearing pullers M40373.
- 4 Mount the axle kit and free wheel body following procedures 2.1.3. and 2.2.2.
- 5 Mount the wheel on the frame, tighten the nuts and adjust the bearing free play with the hub wrench M40123.

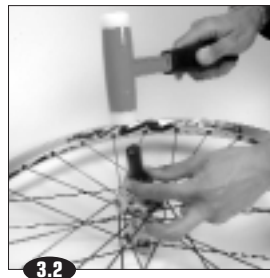

3. WHEEL BUILDING

3.1. REPLACING THE SPOKES

3.1.1. REPLACING THE SPOKES ON THE SPEEDCITY™ AND DEEMAX® UST WHEELS

Tools needed:

- 1 spoke wrench
- 1 tensiometer + tension-reading conversion chart adapted to the tensiometer used.
- 1 hollow screw wrench M40630
- Oil
- Loctite® 243 type of thread lock or equivalent
- One hollow screw per spoke to be replaced (M40595, pack of 40)
- Wire cutters

- 1 Loosen the spoke nipple using the spoke wrench to eliminate the tension.
- 2 Loosen the hollow screw on the damaged spoke using the wrench M40630 (caution, left-hand thread) ;
- 3 Cut the spoke, if necessary, or remove it.
- 4 Install the hollow screw head-first on the spoke, then tighten the spoke nipple until it stops.
- 5 Put the new spoke properly in place. (flat surface of the spoke in the axis of the slot). Then, after gluing the hollow screw with the thread lock, tighten the hollow screw in the rim using the wrench M40630 (caution : left-hand thread, torque: 5.5 Nm).
- 6 Put a drop of oil around the spoke nipple so it doesn't jam on the hollow screw.
- 7 Tighten the spoke nipple to restore the spoke tension: 120 - 130 kg for the front wheel on the disc side and free wheel side on the rear wheel.
- 8 Check the lateral and radial truing of the wheel.

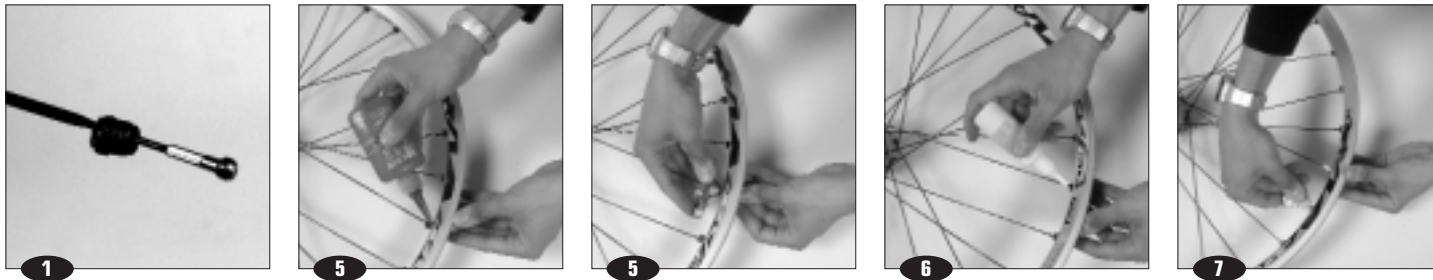

3.1.2. REPLACING THE SPOKES ON THE FRONT CROSSMAX™ SL WHEEL

Tools needed:

- 1 spoke wrench alu M40494 or M40652
- 1 aerodynamic spoke maintenance wrench M40567
- 1 tensiometer + tension-reading conversion chart adapted to the tensiometer used.

- 1 Start by removing the defective spoke:
 - 1.1 Loosen the spoke nipple using the alu spoke wrench M40494 or M40652 ;
 - 1.2 Take the spoke head out of the hub flange by orienting the spoke toward the inside of the wheel and slightly lifting it to be able to pass its head through the hole in the flange.
- 2 Follow the same procedure for removing the defective spoke to insert the new spoke, head first, from the inside of the hub wall, orienting the spoke so its head goes to the bottom of the groove of the wall ;
- 3 Tighten the spoke nipple using the alu spoke wrench M40494 or M40652 ;
- 4 Adjust the spoke tension (120 - 130 kg for the front wheel) ;
- 5 Check the lateral and radial truing of the wheel.

Since the brake ring locks the nipples in place, it is not necessary to use thread lock.

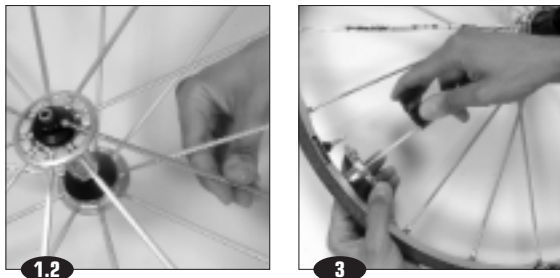

CAUTION : manipulating the integrated nipples greatly affects the spoke tension and consequently the wheel adjustment.
In the final phase of adjusting the tension, 1/4 turn of the nipple corresponds to about 0.3 mm of lateral rim movement.

3.1.3. REPLACING THE SPOKES ON THE REAR CROSSMAX™ SL, FRONT AND REAR CROSSMAX™ SL DISC, FRONT AND REAR CROSSMAX™ XL, AND FRONT AND REAR CROSSMAX™ XL DISC WHEELS

Tools needed:

- 1 spoke wrench alu M40494 or M40652
- 1 x 5 mm Allen wrench (for the front wheel)
- 1 x 10 mm Allen wrench (for the front wheel)
- 1 hub wrench M40123 (for the front wheel)
- 1 tensiometer + tension-reading conversion chart adapted to the tensiometer used.

- When replacing a spoke on the Crossmax™ XL front wheel, you need to remove the axle beforehand by following the procedure described on page 17, and remove the spoke retention plates M40461.
- When replacing a spoke on the free wheel side of the rear wheel, you need to remove the retention clip beforehand and make sure you don't bend it.

- 1 Start by removing the defective spoke :
 - 1.1 Loosen the spoke nipple using the alu spoke wrench M40494 or M40652.
 - 1.2 Remove the spoke head from the hub.
- 2 Mount the new spoke in the hub by pivoting it until it can no longer turn.
- 3 Tighten the spoke nipple using the alu spoke wrench M40494 or M40652 ;
- 4 Adjust the tension (120 - 130 kg for the front wheel disc side (if necessary) and 130 - 140 kgs on the free wheel side of the rear wheel) ;
- 5 Check the lateral and radial truing of the wheel.

Since the brake ring locks the nipples in place, it is not necessary to use thread lock.

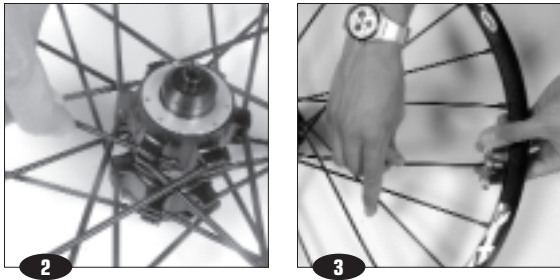

CAUTION : manipulating the integrated nipples greatly affects the spoke tension and consequently the wheel adjustment.
In the final phase of adjusting the tension, 1/4 turn of the nipple corresponds to about 0.3 mm of lateral rim movement.

3.2. REPLACING THE RIM

3.2.1. REPLACING THE RIM ON THE SPEEDCITY™ AND DEEMAX® UST WHEELS

3.2.1.1. Replacing the front rim on the Speedcity™ and Deemax® UST wheels

Tools needed:

- 1 spoke wrench
- 1 tensiometer + tension-reading conversion chart adapted to the tensiometer used.
- 1 hollow screw wrench M40630
- Oil
- Loctite® 243 type of thread lock or equivalent
- A pack of hollow screws (M40595, per packs of 40)

- 1 Prepare the spokes : First place a hollow screw on the spoke head. Then tighten the spoke nipple until it stops.
- 2 Start on the disc side.
- 3 With the rim flat, locate the valve hole and turn the rim so the bar code sticker is facing you, with the valve hole near you.
- 4 Prepare the **1st half of the disc side (non-braking spokes)** :
 - 4.1 Put a spoke in the 1st hole to the right of the valve hole and tighten the hollow screw in the rim one turn, and put the spoke head in the first slot inside the hub, disc side (the flat surface of the spoke in the axis of the slot) ;
 - 4.2 Repeat this procedure for all the slots inside the hub, disc side, 1 hole out of 4 in the rim: the first half on the disc side is ready.
- 5 Then prepare the 2nd half of the disc side (braking spokes) :
 - 5.1 Put a spoke in the 3rd hole to the right of the valve hole and tighten the hollow screw in the rim one turn, and put the spoke head in the outside slot on the hub, disc side, (the flat surface of the spoke in the axis of the slot), crossing over the 1st spokes that were placed.
 - 5.2 Repeat this procedure for all the outside slots on the hub on the disc side, 1 hole out of 4 in the rim : the 2nd half on the disc side is ready.
- 6 Turn the wheel over to prepare the 1st half on the side opposite the disc (non-braking spokes):
 - 6.1 Put a spoke in the 3rd hole to the right of the valve hole and tighten the hollow screw in the rim one turn, and put the spoke head in the inside slot on the hub on the side opposite the disc (the flat surface of the spoke in the axis of the slot);
 - 6.2 Repeat this procedure for all the inside slots on the hub on the side opposite the disc, 1 hole out of 4 in the rim : the first half on the side opposite the disc is ready.
- 7 Finally, prepare the 2nd half of the side opposite the disc (braking spokes) :
 - 7.1 Put a spoke in the 1st hole to the right of the valve hole and tighten the hollow screw in the rim one turn, and put the spoke head in the outside slot on the hub on the side opposite the disc (the flat surface of the spoke in the axis of the slot), crossing over the spokes in the first half.
 - 7.2 Repeat this procedure for all the outside slots on the hub on the side opposite the disc to build the last spokes.
- 8 Put a Loctite® 243 type of thread lock on every hollow screw and tighten each screw using the wrench M40630 (torque 5.5 Nm) ;
- 9 Put a drop of oil around each spoke nipple in the hollow screws so the nipple can turn freely in the screw.
- 10 Adjust the final tension of the wheel : 120 - 130 kg for the disc side of the front wheel. Since the spoke nipples are a type of ABS, it is not necessary to use thread lock.
- 11 Check the lateral and radial truing of the wheel.

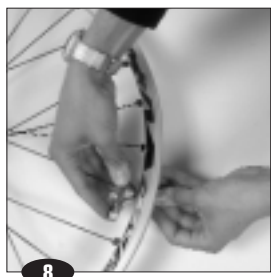
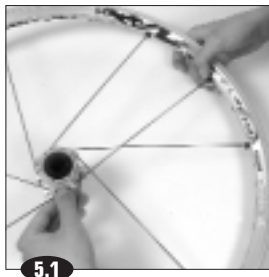
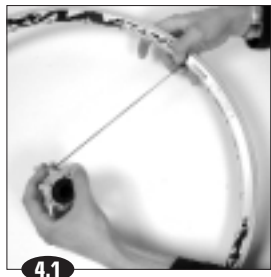
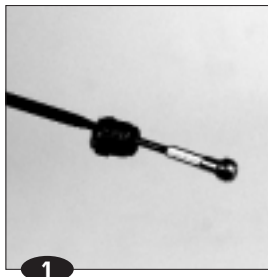

3.2.1.2. Replacing the rear rim on the Speedcity™ and Deemax® UST wheels

Tools needed:

- 1 spoke wrench
- 1 tensiometer + tension-reading conversion chart adapted to the tensiometer used.
- 1 hollow screw wrench M40630
- Oil
- Loctite® 243 type of thread lock or equivalent
- A package of hollow screws (M40595, per packet of 40)

- 1** Prepare the spokes : First put a hollow screw on the spoke head. then tighten the spoke nipple until it stops.
- 2** Start on the free wheel side.
- 3** With the rim flat, locate the valve hole and turn the rim so the bar code sticker is facing you, with the valve hole near you.
- 4** Prepare the 1st half of the free wheel side (braking spokes) :
 - 4.1** Put a spoke in the 1st hole to the right of the valve hole and tighten the hollow screw in the rim one turn, and put the spoke head in the slot inside the hub, free wheel side (the flat surface of the spoke in the axis of the slot).
 - 4.2** Repeat this procedure for all the slots inside the hub, free wheel side, 1 hole out of 4 in the rim: the first half free wheel side is ready;
- 5** Then prepare the 2nd half of the free wheel side (tractor spokes) :
 - 5.1** Put a spoke in the 3rd hole to the right of the valve hole and tighten the hollow screw in the rim one turn, and put the spoke head in the outside slot on the hub, free wheel side (the flat surface of the spoke in the axis of the slot) crossing over the 1st spokes mounted.
 - 5.2** Repeat this procedure for all the outside slots on the hub, free wheel side, 1 hole out of 4 in the rim : the 2nd half free wheel side is ready.
- 6** Turn the wheel over to prepare the 1st half on the side opposite the free wheel (tractor spokes) :
 - 6.1** Put a spoke in the 1st hole to the right of the valve hole and tighten the hollow screw in the rim one turn, and put the spoke head in the slot inside the hub on the side opposite the free wheel (the flat surface of the spoke in the axis of the slot).
 - 6.2** Repeat this procedure for all the inside slots on the hub on the side opposite the free wheel, 1 hole out of 4 in the rim : the first half on the side opposite the free wheel is ready.
- 7** Finally, prepare the 2nd half on the side opposite the free wheel (braking spokes) :
 - 7.1** Put a spoke in the 3rd hole to the right of the valve hole and tighten the hollow screw in the rim one turn, and put the spoke head in the outside slot on the hub on the side opposite the free wheel (the flat surface of the spoke in the axis of the slot) crossing over the spokes from the half.
 - 7.2** Repeat this procedure for all the outside slots on the hub on the side opposite the free wheel to build the last spokes.
- 8** Put a Loctite® 243 type of thread lock on every hollow screw and tighten each screw using the wrench M40630 (torque 5.5 Nm) ;
- 9** Put a drop of oil around each spoke nipple in the hollow screws so the nipple can turn freely in the screw.
- 10** Adjust the final tension of the wheel : 130 - 140 kg for the free wheel side of the front wheel. Since the spoke nipples are a type of ABS, it is not necessary to use thread lock.
- 11** Check the lateral and radial truing of the wheel.

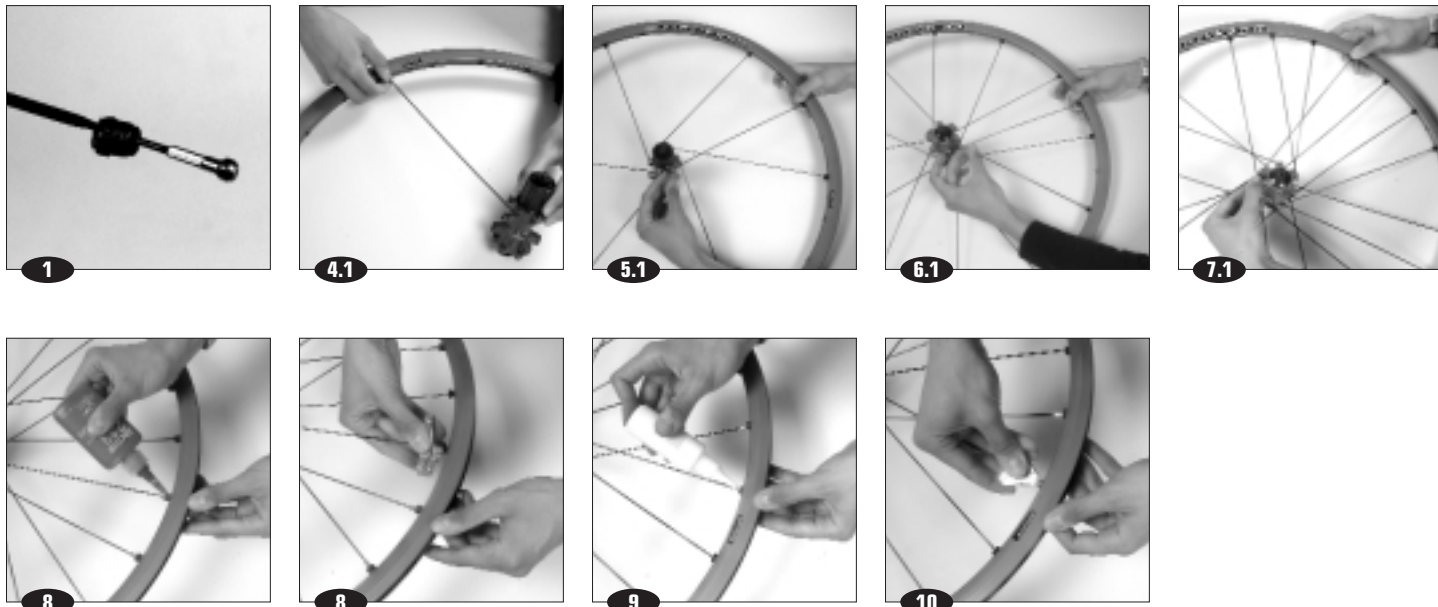



3.2.2. REPLACING THE RIM ON THE CROSSMAX™ SL AND CROSSMAX™ XL WHEELS

3.2.2.1. Replacing the front rim on the Crossmax™ SL wheel

Tools needed:

- 1 spoke wrench alu M40494 or M40652
- 1 aerodynamic spoke maintenance wrench M40567
- 1 tensiometer + tension-reading conversion chart adapted to the tensiometer used.

- 1 Start with the hub with the adjustment nut facing you.
- 2 Insert a spoke in a hole in the hub wall, head first, from inside the wall, orienting the spoke so its head is at the bottom of the groove of the wall.
- 3 Tighten the spoke in the first hole to the right of the valve hole one turn (1 raised indicator bump near this hole).
- 4 Repeat these 2 procedures for all the spokes on the side with the adjustment nut, and then for the side opposite the adjustment nut.
- 5 Tighten each spoke evenly (1/2 turn for each spoke per wheel) to put tension on the wheel.
- 6 Adjust the definitive tension and centering of the wheel (120 - 130 kg for the front wheel).

Since the brake ring locks the nipples in place, it is not necessary to use thread lock.

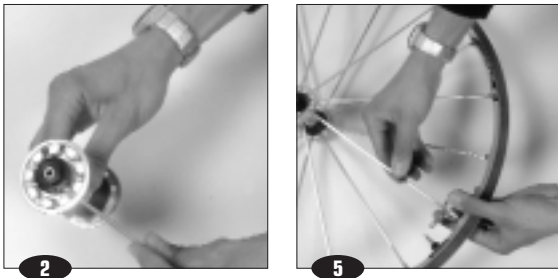

When spokes are missing, the 2 walls can pivot in relationship to each other. However, under the effect of the tension of the spokes, they will go back to their proper position.

CAUTION : manipulating the integrated nipples greatly affects the spoke tension and consequently the wheel adjustment.
In the final phase of adjusting the tension, 1/4 turn of the nipple corresponds to about 0.3 mm of lateral rim movement.

3.2.2.2. Replacing the front rim on the Crossmax™ XL wheel

Tools needed:

- 1 spoke wrench alu M40494 or M40652
- 1 aerodynamic spoke maintenance wrench M40567
- 1 tensiometer + tension-reading conversion chart adapted to the tensiometer used.

- 1 Disassemble the axle as described in procedure 1.1. and remove the spoke retention plates.
- 2 Tighten a spoke in every threaded rim hole (1 turn);
- 3 Put the spokes in the hub by pivoting them around themselves until they can't turn anymore.
- 4 Mount the spoke retention plates and the hub axle as described in procedure 1.1.
- 5 Tighten every spoke evenly (1/2 turn for every spoke on the wheel) to put tension on the wheel.
- 6 Adjust the definitive tension and centering of the wheel (120 - 130 kg on the front wheel).

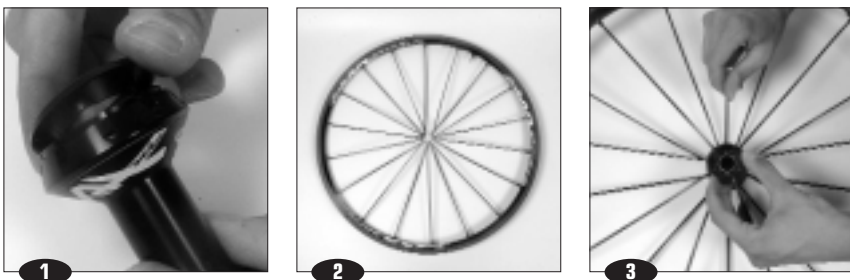

CAUTION : manipulating the integrated nipples greatly affects the spoke tension and consequently the wheel adjustment.
In the final phase of adjusting the tension, 1/4 turn of the nipple corresponds to about 0.3 mm of lateral rim movement.



3.2.2.3 Replacing the rear rim on the Crossmax™ SL and Crossmax™ XL wheels

Tools needed:

- 1 spoke wrench alu M40494 or M40652
- 1 aerodynamic spoke maintenance wrench M40567
- 1 tensiometer + tension-reading conversion chart adapted to the tensiometer used.

- 1 Start on the free wheel side.
 - 2 Turn the rim facing you to have the 2 raised indicator bumps to the right of the valve hole (valve hole near you) and prepare the free wheel side:
 - 2.1 Put a spoke in the first hole to the right of the valve hole (hole near the raised indicator bumps) tightening the integrated nipple in the rim one turn and proceed in the same manner, 1 hole out of 2 for all the spokes on the free wheel side (radial spokes).
 - 2.2 Put the spokes in the hub on the free wheel side. Pivot the spokes around themselves until they can't turn anymore. Starting from the valve hole, the 1st and 3rd spokes go in the same slot. The other spokes on this side are positioned in the same manner: by groups of 2 in the same slot.
 - 2.3 Mount the spoke retention clip and make sure you don't bend it.
 - 3 Turn the wheel over to prepare building the side opposite the free wheel:
 - 3.1 Tighten a spoke in the first hole to the right of the valve hole one turn and mount this spoke in the inside slot on the hub on the side opposite the free wheel. This is a pulling spoke. Pivot it around itself and make sure it can't turn anymore.
 - 3.2 Proceed in the same manner for all the pulling spokes: 1 hole out of 4 in the rim and always in the inside slots on the hub on the side opposite the free wheel.
 - 3.3 Then mount the braking spokes in the outside slots on the hub on the side opposite the free wheel and tighten them 1 turn in the remaining rim holes. Pivot them around themselves and make sure they can't turn anymore.
 - 4 Tighten every spoke evenly (1/2 turn for every spoke on the wheel) to put tension on the wheel.
 - 5 Adjust the definitive tension and centering of the wheel (130 - 140 kg for the rear wheel on the free wheel side).
- Since the brake ring locks the nipples in place, it is not necessary to use thread lock.

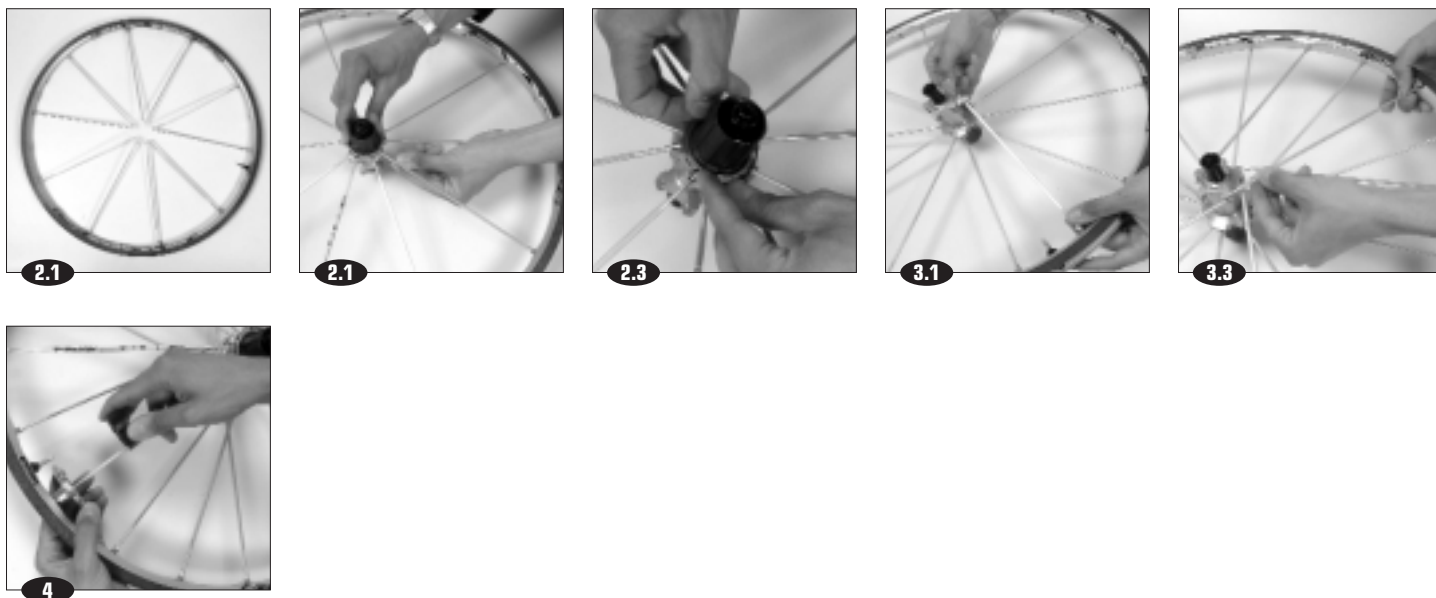

CAUTION : manipulating the integrated nipples greatly affects the spoke tension and consequently the wheel adjustment.
In the final phase of adjusting the tension, 1/4 turn of the nipple corresponds to about 0.3 mm of lateral rim movement.



3.2.3. REPLACING THE RIM ON THE CROSSMAX™ SL DISC AND CROSSMAX™ XL DISC WHEELS

3.2.3.1. Replacing the front rim on the Crossmax™ SL Disc and Crossmax™ XL Disc wheels

Tools needed:

- 1 spoke wrench alu M40494 or M40652
- 1 aerodynamic spoke maintenance wrench M40567 (for the wheel Crossmax™ SL Disc)
- 1 tensiometer + tension-reading conversion chart adapted to the tensiometer used.

- 1 Turn the rim to have the valve hole near you and :
 - the raised indicator bumps to the right of the valve hole, on the Crossmax™ SL Disc.
 - the print on the valve sticker non-visible, on the Crossmax™ XL Disc.
- 2 Start building the 1st half on the disc side (non-braking spokes) :
 - 2.1 Put a spoke in the 1st hole to the right of the valve hole.
 - 2.2 Put the head of this spoke in the inside slot of the hub on the disc side. Then tighten the spoke nipple in the rim 2 turns. Pivot the spoke around itself until it can no longer turn.
 - 2.3 Repeat these 2 steps for all the inside slots on the disc side and put a spoke in every 4th hole in the rim.
- 3 Then prepare building the 2nd half on the disc side (braking spokes) :
 - 3.1 Put a spoke in the 3rd hole to the right of the valve hole.
 - 3.2 Put the head of this spoke in the outside slot on the hub on the disc side. Then tighten the spoke nipple in the rim 2 turns. Pivot the spoke around itself until it can no longer turn.
 - 3.3 Repeat these 2 steps for all the outside slots on the disc side and put a spoke in every 4th hole in the rim.
- 4 Now prepare building the 1st half on the side opposite the disc (non-braking spokes) :
 - 4.1 Put a spoke in the 3rd hole to the right of the valve hole.
 - 4.2 Put the head of this spoke in the inside slot on the hub on the side opposite the disc. Then tighten the spoke nipple in the rim 2 turns. Pivot the spoke around itself until it can no longer turn.
 - 4.3 Repeat these 2 steps for all the inside slots on the side opposite the disc and put a spoke in every 4th hole in the rim.
- 5 Finally, prepare building the 2nd half on the side opposite the disc (braking spokes) :
 - 5.1 Put a spoke in the 1st hole to the right of the valve hole.
 - 5.2 Put the head of this spoke in the outside slot on the hub on the side opposite the disc. Then tighten the spoke nipple in the rim 2 turns. Pivot the spoke around itself until it can no longer turn.
 - 5.3 Repeat these 2 steps for all the outside slots on the side opposite the disc and put a spoke in every 4th hole in the rim.
- 6 Tighten every spoke evenly (1/2 turn for each spoke on the wheel) .
- 7 Adjust the definitive tension and centering of the wheel (120 - 130 kg on the front wheel disc side)
Since the brake ring locks the nipples in place, it is not necessary to use thread lock.

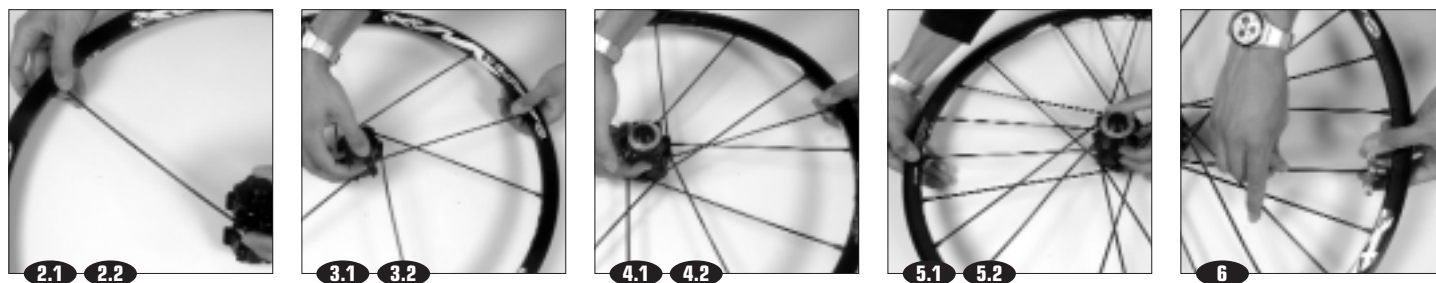
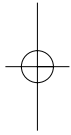

CAUTION : manipulating the integrated nipples greatly affects the spoke tension and consequently the wheel adjustment.
In the final phase of adjusting the tension, 1/4 turn of the nipple corresponds to about 0.3 mm of lateral rim movement.

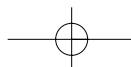

3.2.3.2. Replacing the rear rim on the Crossmax™ SL Disc and Crossmax™ XL Disc wheels

Tools needed:

- 1 spoke wrench alu M40494 or M40652
- 1 aerodynamic spoke maintenance wrench M40567 (for the Crossmax™ SL Disc wheel)
- 1 tensiometer + tension-reading conversion chart adapted to the tensiometer used

- 1 Start on the free wheel side with the rim flat.
 - 2 Turn the rim to have the valve hole near you and:
 - the 2 raised indicator bumps to the right of the valve hole, on the Crossmax™ SL Disc.
 - the print on the valve sticker visible, on the Crossmax™ XL Disc.
 - 3 Prepare building the free wheel side:
 - 3.1 Tighten the nipple on one spoke 2 turns in the 1st hole located to the right of the valve hole and insert its head in the slot on the hub on the free wheel side so it is braking (the deepest slot). Follow the same procedure 1 out of every 4 holes.
 - 3.2 Tighten the nipple on one spoke 2 turns in the 3rd hole located to the right of the valve hole and insert its head in the slot on the hub on the free wheel side so it is pulling (the most shallow slot). Follow the same procedure 1 out of every 4 holes.
 - 4 Mount the spoke retention clip and make sure you don't bend it.
 - 5 Turn the wheel over and prepare building the 1st half on the side opposite the free wheel (pulling spokes):
 - 5.1 Tighten the nipple on one spoke 2 turns in the 1st hole to the right of the valve hole and insert the head of the spoke in the inside slot on the hub on the side opposite the free wheel so it is pulling. Pivot the spoke around itself until it can no longer turn.
 - 5.2 Proceed in the same manner for the rest of this first half on the side opposite the free wheel, 1 hole out of 4 in the rim and on the inside slots on the hub on the side opposite the free wheel.
 - 6 Finally, prepare the 2nd half on the side opposite the free wheel (braking spokes) :
 - 6.1 Tighten the nipple on a spoke 2 turns in the 3rd hole to the right of the valve hole and insert the head of the spoke in the outside slot on the hub on the side opposite the free wheel so it is braking. Pivot the spoke around itself until it can no longer turn.
 - 6.2 Proceed in the same manner for the rest of the wheel, 1 hole out 4 in the rim and in the outside slots on the hub on the side opposite the free wheel.
 - 7 Tighten every spoke evenly (1/2 turn for each spoke on the wheel) to put tension on the wheel.
 - 8 Adjust the definitive tension and centering of the wheel (130 - 140 kg for the rear wheel on the free wheel side).
- Since the brake ring locks the nipples in place, it is not necessary to use thread lock.

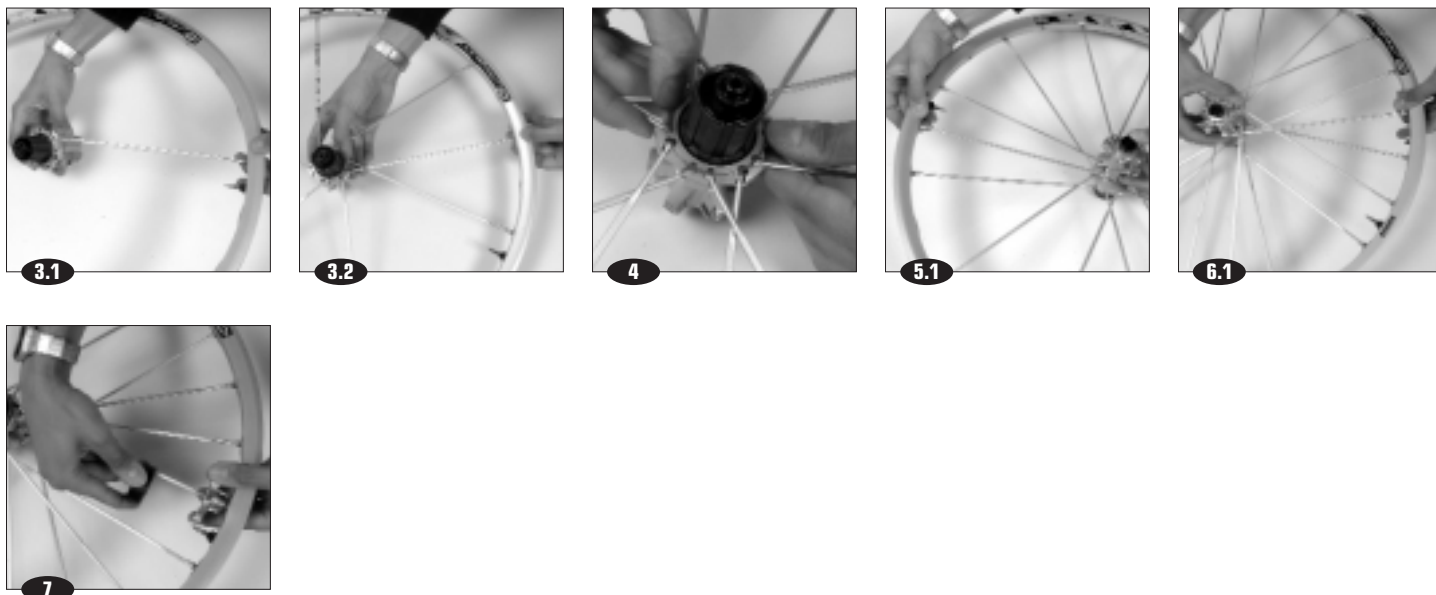

CAUTION : manipulating the integrated nipples greatly affects the spoke tension and consequently the wheel adjustment.
In the final phase of adjusting the tension, 1/4 turn of the nipple corresponds to about 0.3 mm of lateral rim movement.

THE MAVIC® RIMS

SEGMENTATION OF THE RIM RANGE

ROAD			ASPHALT	MTB		
CLINCHER		TUBULAR		CROSS COUNTRY	CROSS MOUNTAIN	MTB EXTREME
CLASSIC	PROFILED	CLASSIC				
OPEN PRO	CXP33	REFLEX	T520	X317 DISC X517 X3.1 DISC (UST) X3.1 (UST) New X618	F519	D3.1 DISC (UST) New D321 DISC D521
MA3	CXP23		T224 T223 DISC (HRB)*	X223 DISC* X225* X221	F219 DISC	
	CXP22 New			X139 DISC* New X139*		

* Specific O.E.M. rims.

RIMS





GENERAL POINTS

All Mavic® rims are based on these four principles :

- aluminum alloy profile (6000 series) specified by Mavic®.
 - double wall profile for greater strength and rigidity.
 - anodization for its corrosion-resistance and aesthetic qualities while facilitating maintenance.
 - the eyelet allows for better distribution of the pressure exerted by the spoke and increases the strength and durability of the Mavic® rim.
- The profiled eyelet (Mavic® patent) combines the benefits of both the profiled rim and eyelet.

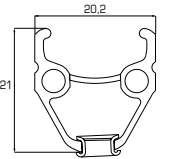
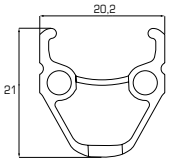
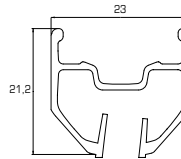
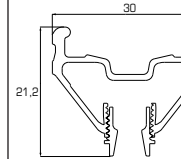
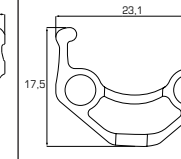
WHAT'S NEW FOR 2003

5 new rims are introduced in the 2003 range. Their features are the following:

	ROAD RIMS		MTB RIMS		
	CXP 22 S	CXP22 N (OEM only)	X3.1	D3.1 DISC	X139 DISC (OEM only)
Rim width					
Technologies					
Material	6106	6106	Maxtal	Maxtal	6106
Valve hole diameter (in mm)	6,5	6,5	6,5	6,5	8,5 with adapter
ETRTO compatibility	622 x 15	622 x 15	559 x 17	559 x 23	559 x 17
Recommended tire width	19 à 28	19 à 28	1,5 à 2,3	2,0 à 2,8	1,5 à 2,3
Eyelets	Single	Without	Fore® hollow screws	Fore® hollow screws	Without
Average weight (in grams)	500	490	465	580	460
Finish and drilling Mavic black	32, 36	32, 36	28, 32	32	32
Recommended spoke nipple length	12	12	16	16	12
Spoke support diameter	596 mm	596 mm	532 mm	532 mm	545,5 mm
Recommended rim tape (ETRTO x width x thickness)	622 x 18 x 0,6	622 x 18 x 0,6	Do not use rim tape	Do not use rim tape	559 x 18 x 0,6
Wear & tear indicator	Integrated in the profile	Integrated in the profile	No	-	-

for building the rims D3.1 Disc and X3.1, consult the building instructions delivered with the rim, the 2002 technical manual, page 21 or the website HYPERTEXT LINK <http://www.tech-mavic.com>.



THE WEAR & TEAR INDICATOR

Mavic® has chosen to provide every one of its new rim profiles that has a braking surface with a wear & tear indicator.
2 types of wear & tear indicators are used on our rims:

MACHINED :

Process : the inside of the braking surface of the rim is machined on both of the wings on the rim.

Principle: a little hole appears on each of the 2 braking surfaces on the rim, when there is too much wear & tear on the rim.

Depending on the adjustment of the brake pads, it is possible for the wear & tear indicator to appear on only one of the 2 braking surfaces.

In any case, **the appearance of the wear & tear indicator on at least one of the 2 braking surfaces means that the wings are too thin,**

The position of the wear indicator is marked by 2 yellow arrows on the stickers on the rim, opposite the valve hole.

INTEGRATED IN THE PROFILE :

Process : the wear & tear indicator is an integral part of the profile of the rim. There is a groove on the entire circumference of the rim, at the center of the braking surface.

Principle : The groove becomes more shallow as the braking wears down the surface of the rim. **Its disappearance, on one side of the rim or the other, signifies that the thickness of the braking surfaces is too thin, and it could be dangerous to continue to use the rim. It should be replaced as soon as possible.**

By preventing the braking surfaces from wearing down, the Ceramic® coating is considered as a wear & tear indicator and can be a substitute.

CONDITIONS OF USE FOR A RIM

CONDITIONS OF USE TO BE GIVEN TO YOUR CUSTOMERS:

Mavic® uses the most advanced technology in the design of its rims and wheels. However, a rim cannot last forever and wears down according to its use : type of riding, terrain, brake pad, spoke tension, tires, tire pressure, weather conditions, etc.

Each rim has been designed for a specific use and discipline (road, cross country, downhill, touring). Any other use of a rim for which it has not been designed is highly inadvisable and is the sole responsibility of the user, which voids the Mavic® warranty.

Please advise customers of the following:

- Choose a suitable rim designed for the type of riding you wish to do: Do not use cross country rims on wheels that will be mounted on free ride, downhill or dual bikes.
- Respect the instructions for tire pressure and dimensions mentioned in this Technical Manual (see following diagrams).
- Respect appropriate tension of spokes. Mavic® recommends tension of spokes between 70 - 90 kg (for a front or rear wheel on the free wheel side with 3 cross pattern). Inappropriate tension of spokes can generate too much stress and damage the rim.
- Rims must be cleaned on a regular basis with Mavic® abrasive eraser (M40410).
- Remove gravel or metal particles in the brake pads.
- Replace the brake pads when they are worn.
- Discontinue use of a rim if the braking surfaces are worn, if eyelets are missing, or in any other case where safety might be compromised. The rim is a component that gets worn out in the same way as the brake pads, and must be replaced if it is worn (sidewalls hollowed by wear or indented, cracked rim...),
- For the T520 and T224, do not continue to use the rim if the wear & tear indicator appears or disappears on at least one of the 2 braking surfaces.
- Check or have your rims checked on a regular basis. If this is not possible, check them at least in the beginning of each season and after intensive use. When checking, look inside (especially under the rim tape) and the outside rim. Look for signs of fatigue or wear, damage to the braking surfaces, appearance or disappearance of the wear & tear indicator (only for the T520 and T224 and CXP22), or cracks in the walls around the eyelets.

Following these recommendations will guarantee longer product life for the rims, maximum performance and riding enjoyment.



RECOMMENDED TIRE PRESSURE

RECOMMENDED MAXIMUM TIRE PRESSURE:

CROSS-COUNTRY AND CROSS-MOUNTAIN*

Tire width		Maximum pressure (bars)	Maximum pressure (PSI)
in "	in mm		
1,00	25	7,70	113,00
1,20	30	7,00	103,00
1,50	38	6,00	88,00
1,75	45	5,20	76,00
1,85	47	4,80	71,00
1,90	48	4,70	69,00
1,95	50	4,50	66,00
2,00	51	4,30	63,00
2,10	53	4,00	59,00
2,20	56	3,70	55,00
2,50	63	2,70	40,00

EXTREME MOUNTAIN BIKE*

Tire width		Maximum pressure (bars)	Maximum pressure (PSI)
in "	in mm		
2,00	51	3,80	56
2,10	53	3,70	55
2,20	56	3,50	52
2,30	58	3,30	49
2,40	61	3,20	47
2,50	63	3,00	44
2,60	66	2,80	41
2,70	68	2,70	39
2,80	71	2,50	36

ROAD*

Tire width in mm	Maximum pressure (bars)	Maximum pressure (PSI)
19	10,0	146
23	9,5	138
25	9,0	131
28	8,0	117

ASPHALT*

Tire width in mm	Maximum pressure (bars)	Maximum pressure (PSI)
28	7,00	103,00
30	7,00	103,00
32	7,00	103,00
35	6,00	88,00
37	6,00	88,00

*See page 31 for riding segmentation chart.

DURABILITY :

A rim has two main functions : to support the tire and serve as a brake disc.

In the framework of this second function as a braking surface, rims may be subject to wear, especially from intensive or prolonged use. Rims may experience wear for reasons as diverse as the encrustation of gravel or mud in the brake pads or the use of worn or poorly adjusted brake pads. These can wear down or damage the rim sidewalls, and may not be noticed by the user.

It is common for the user to have the rims replaced as he would the brake pads.

You must make your customers aware of this.

To reduce wear and tear, we have developed CERAMIC coating on our top-of-the-line rims (see below).

If, following a violent shock the rim is heavily out of true, the rim should be replaced as soon as possible, in order to avoid overloading or even rupture.

MAINTENANCE :

Rims and brake pads must be cleaned with soap and water on a regular basis. Abrasive substances (sand...) may have been deposited during use and could scratch or significantly damage the sidewalls of rims.

If the cleaning is not sufficient on the braking surfaces, use a Mavic® abrasive eraser M40410 (except on rims designed specifically for disc brakes). Only use the Mavic® abrasive eraser, a sponge, or a cloth.

If grease exists on a rim, it may be removed with any type of solvent without risking damage to the rim (except on the rim of the Deemax® wheel). However, do not use any solvents in the area of the sticker or tire, as there is risk of damage to the sticker and tire.



BRAKE PADS :

Adjusting the brake pads :

The brake pads should be positioned on the braking surface of the rim, as shown in the diagrams below:

Road rim :

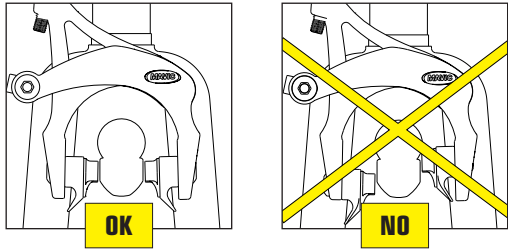

MTB rim :

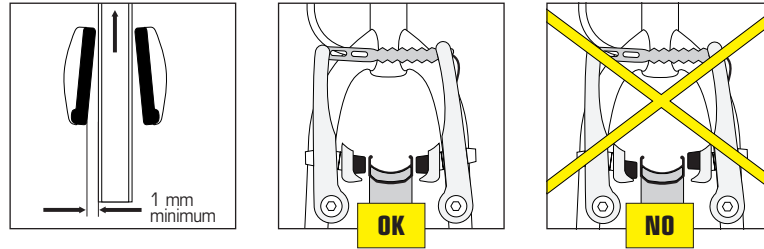

Recommendations for use and type of brake pad.

For proper braking:

- Clean the brake pads with the Mavic® abrasive eraser M40410.
- Avoid all types of greasy substances on the braking surface.
- Use brake pads that are adapted to the specific rim coating. Certain brake manufacturers offer specific Ceramic pads. These pads should be used only with Ceramic rims to avoid prematurely damaging the braking surface. Nevertheless, Mavic® will never be able to guarantee the perfect appropriateness between the brake pads of the different manufacturers with its different coatings on the braking surface (UB Control, Ceramic).
- On your road calipers, (except ED), you can use the Mavic® brake pads M40498. The rubber on these brake pads is perfectly adapted to the Mavic® rims (excluding Ceramic).
- Check the degree of wear and tear and the smoothness of the brake pads. Replace them on a regular basis.

To avoid braking noise, optimize the adjustment of the braking system by following the recommendations above, but also by trying to adjust the different pad angles, and by mounting (if necessary) a stiffener.

CHARACTERISTICS OF THE CERAMIC® COATING:

The main advantage of this coating is that it **reduces the braking distance** in wet conditions and **increases the durability of the rim**. Initially, the wear and tear of the brake pads will be greater with this type of coating than with a conventional treatment.

Consequently, use brake pads specifically manufactured for rims with Ceramic coating.

Also, since this Ceramic coating is very hard, it is also sensitive to impacts.

A hard impact could cause cracks in the Ceramic coating, **which would have no effect on the efficiency of the braking**.

TUBULAR TIRE MOUNTING

Tools needed:

- solvent.
- compressed air
- high grade tubular tire glue
- small paint brush
- steel wool.

Process :

Any previously used rim and/or tire must be thoroughly cleaned and free of old glue before mounting.

The rim should be cleaned with acetone or a similar product before application of glue.

- 1 Prepare the clean tire mounting surface of the rim by rubbing it with steel wool.
- 2 Thoroughly coat the prepared mounting surface with glue, using a small paintbrush.
- 3 After the glue has dried, repeat process twice and allow the final coat of glue to dry (the rim should have at least three dry coats of glue).
- 4 Inflate the tire and coat the tire base tape (inside diameter of tire) with glue.
- 5 Deflate (not completely) the tire while the glue is still wet and insert the valve stem through the valve stem hole of the rim. Carefully stretch the tire onto the rim, working evenly from both sides of the valve stem, to the point opposite the valve stem.
- 6 Adjust the position of the tire until it is centered on the rim.
- 7 Inflate the tire to 45-60 PSI (3-4 bars). Allow the glue to dry for 12 hours before riding on the tire. Then inflate to the pressure indicated on the tube.





SPECIAL CONDITIONS OF USE FOR A RIM WITH DISC BRAKES

This type of rim is specifically designed to be used with disc brakes and is characterized by:

- the absence of a braking surface.
- the specific shape and thickness of the profile.

For these reasons, these rims must be used only with disc brakes and never with cantilever or V-brakes. These conditions also apply to the rims X223 DISC, X317 DISC, D321 DISC, F219 DISC, X3.1 DISC and D3.1 DISC, but also on the wheels Deemax, Deemax® UST, Crossmax™ Disc, Crossmax™ UST Disc, Crossmax™ SL Disc, Crossmax™ XL Disc and Crossroc™ Disc or when the following sticker is positioned on your rim :

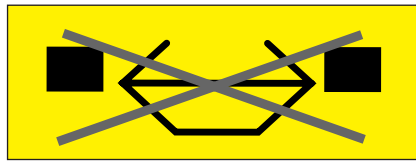

Wheel building recommendations:

Wheel building for this type of rim must be adapted to the strong forces that result from disc braking.

Mavic® recommends to specifically orient the braking spokes (spokes on the outside of the hub flange) on the side of the disc so that they work in the direction of the torque exerted by the disc on the hub.

Therefore, please follow the direction of the spokes on the hub flanges as is shown in these diagrams:

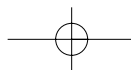
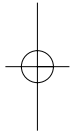
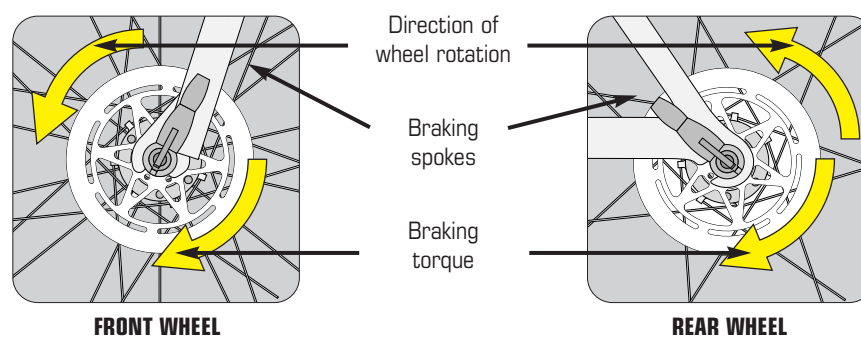

SPECIAL CONDITIONS FOR USING AN UST™ TUBELESS RIM

The ETRTO norm now integrates the tubeless concept. As a result, and on the condition of respecting certain conditions of use, a UST™ rim can officially, and without risk, be combined with a classic tire and a tube.

USE OF A UST™ TUBELESS RIM WITH A UST™ TUBELESS TIRE

Especially after building a UST™ TUBELESS rim and mounting a UST™ TUBELESS tire, we recommend making sure the wheel/tire unit is airtight by proceeding as follows:

- 1 Immerse the tire/wheel unit in the container of water.
- 2 Make sure the unit is airtight, by inspecting the tire and the rim (especially around the spokes) looking for air bubbles.
- 3 If there is a leak:
 - Between the tire and the rim: replace or repair the UST™ TUBELESS tire.
 - Around the UST™ valve : replace the UST™ valve.
 - Around the hollow screws, spoke nipples or Zicral spoke screws: replace the rim.

Caution: the air contained between the 2 bridges of the rim will naturally have a tendency to escape because of the pressure of the water and could be the origin of the air bubble. Therefore, check this phenomena before planning on replacing the rim.

USE OF A UST™ TUBELESS RIM WITH A CLASSIC TIRE AND A TUBE

The 3 main conditions for using a UST™ tubeless rim with a classic tire and a tube are:

- only use ETRTO compatible tires.
- only use tubes with a Presta type of valve (ø 6,5);
- use a UST™ Tubeless rim WITHOUT rim tape;

Once the UST™ Tubeless valve has been removed, you can only insert a Presta type of tube (small valve, ø 6.5 mm) into the valve hole of the UST™ Tubeless rim.

Caution: never try to make the valve hole bigger or to drill it. If you do, you could permanently damage the rim and would not be able to use the UST™ valve, which is necessary to keep the rim airtight.

When mounting a classic tire on a UST™ Tubeless rim, follow the same procedure as when using a UST™ Tubeless tire. That is:

- 1 Abundantly moisten the rim tape and tire beads with soap and water ;
- 2 Insert the first tire groove into the bottom of the rim groove ;
- 3 Place the Presta tube in the classic manner;
- 4 Then install the second bead by starting on the opposite side of the valve and finishing at the valve ;
- 5 Center the heels of the tire on both sides of the valve ;
- 6 Rotate the tire to make sure the beads are properly placed at the bottom of the rim groove ;
- 7 Inflate the tire energetically until the tire beads lock into place. The locking action can generate a series of short sounds due to the tire rising to its final position. **Inflate up to 5 bars to be sure that the tire is firmly in place. Being locked in place does not make the tire/rim system completely airtight, but it does guarantee that the tire is properly held in place. In this way, the tire will be properly placed in the rim groove and you can ride without risk of it rolling off the rim.**
- 8 Adjust the tire pressure to your type of riding and preference. Caution: When using a UST™ rim with a classic tire and tube, the adjustment of the pressure is not "without risk", just like on "all UST™" assembly (tire + rim).



SSC™ BRAKES, TOOLS AND CUSTOMER SERVICE

SSC™ BRAKES

WEIGHT : 314 g a pair of calipers.

REFERENCE : M70037

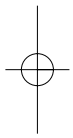
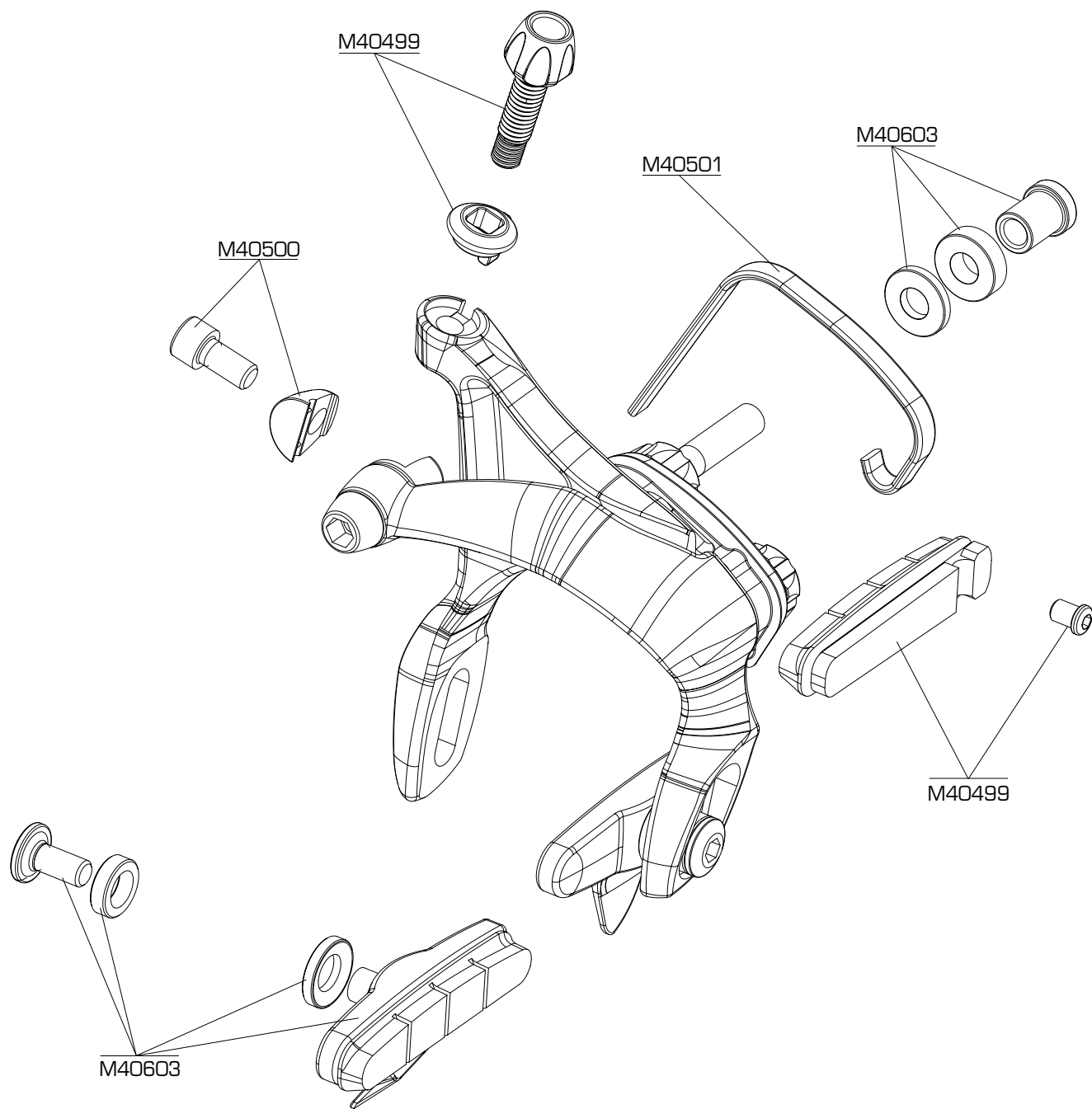

BRAKE MAINTENANCE

Tools needed:

- 1 x 5 mm Allen wrench
- 1 x 4 mm Allen wrench
- 1 x 2.5 mm Allen wrench
- Grease

REPLACING THE SPRING M40501 :

- 1 Unclip the spring by depressing the rectilinear part of the spring.
 - 2 Replace the spring.
 - 3 Insert the new spring in the caliper by first inserting the spring hook and finishing with the rectilinear part (to be inserted behind the caliper pin).
 - 4 Make sure the spring is well-placed by manipulating the caliper at least 10 times.
- It is not necessary to remove the caliper from the frame to replace the spring.

REPLACING THE CABLE CLAMP KIT M40500 :

- 1 Loosen the cable clamp screw using the 4 mm Allen wrench.
- 2 Replace the cable clamp and the screw.
- 3 Put grease on the cable clamp screw thread.

Caution : do not put grease on the cable clamp groove.

- 4 Install the cable clamp and cable clamp screw unit by passing the brake cable in the groove.
- 5 Adjust the tension of the cable and tighten the cable clamp screw using the 4 mm Allen wrench. **Torque : 7 - 9 Nm.**

REPLACING THE BRAKE PAD SET / BRAKE SHOES M40497

- 1 Loosen the brake shoe screw using the 4 mm Allen wrench.
- 2 Loosen the brake pad screw using the 2.5 mm Allen wrench.
- 3 Replace the brake pad.

Caution : make sure the brake pad corresponds to the brake shoe (left brake pad L/ right brake pad R).

- 4 Install the brake pad in the brake shoe and tighten the brake pad screw using the 2.5 mm Allen wrench. **Torque: 0.8 Nm.**
- 5 Install the brake shoe on the caliper with the support washer under the head of the screw and the joint on the brake shoe.
- 6 Place the brake shoe in the proper position in relationship to the braking surface on the rim and tighten the screw using the 4 mm Allen wrench. **Torque: 4 - 6 Nm.**







It is possible to remove the brake pad without removing the brake.

REPLACING THE ADJUSTABLE CABLE STOP M40499 :

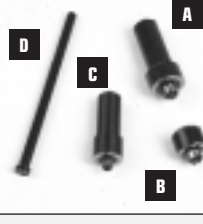
- 1 Loosen the cable clamp screw using the 4 mm Allen wrench and remove the brake cable.
- 2 Loosen the adjustable cable stop.
- 3 Replace the adjustable cable stop and the brake cable stop.
- 4 Grease the thread on the adjustable cable stop.
- 5 Install the brake of the adjustable cable stop in the caliper groove.
- 6 Tighten the adjustable cable stop so it is in contact with the adjustable cable stop brake.
- 7 Install the brake cable and tighten the cable clamp screw using the 4 mm Allen wrench.

Torque : 7 - 9 Nm.

MAVIC® TOOLS

REFERENCE	NAME	PRODUCT
M40119	Bearing press kit for the wheels: Crossmax™, Crossmax™ UST, Crossmax™ XL and Crossmax™ SL (rear wheel only) Crossmax™ Disc, Crossmax™ UST Disc, Crossmax™ XL Disc and Crossmax™ SL Disc Crossland Deemax and Deemax® UST (rear wheels only) Hélium Ksyrium SSC, Ksyrium SSC SL Ksyrium Elite (rear free wheel side only)	
M40120	Bearing press kit for the wheels: Cosmic® Carbone, Cosmic® Carbone SSC Classics Pro, Classics Pro CD, Classics SSC Cosmic® Pro, Cosmic® Expert, Cosmic® Equipe Comète Crossmax™ SL (front wheel only)	
M40631	Bearing press kit for the wheels: Crossroc™ UST Crossroc™ UST Disc	
M40373	Bearing press kit and guide ring for the wheels: Crosslink, Crosslink Disc Crossride, Crossride Céramic Classics Elite, Cosmic® Elite (1st and 2nd generation) Cosmos™ (all colors) Ksyrium Elite (except rear free wheel side) iO™ Speedcity™	
M40218	Bearing press kit for the Deemax® and Deemax® UST front wheel.	
M40410	Mavic® abrasive eraser for cleaning the braking surface of the rim, Ceramic or UB Control.	
M40413	Mektronic tester Function : this tester checks the function of the different elements in the Mektronic system installed on a bike. Installation : this tester is positioned in place of the Mektronic computer originally installed on the bike. After reading the user's guide delivered with this tester, it allows you to easily, quickly and efficiently detect a possible breakdown of any one of the different elements in the Mektronic system. Then you just have to replace the identified element and initialize the system (see page 31 in the 2001 Technical Manual).	

A+B : Bearing press kit for the front wheel.









A+C : Bearing press kit for the rear wheel.

D : Bearing press kit for the front and rear wheels.

E : Bearing press kit for front and rear wheels.

F : Guide ring for the 12 mm Allen wrench needed for removing the free wheel on the wheels Crossroc™ UST, Crossroc™ UST Disc, Crossride®, Crossride® Céramic, Cosmos® and Cosmic® Elite.

MAVIC® TOOLS

REFERENCE	NAME	PRODUCT
M40001	Spoke adjustment wrench for the Cosmic® Carbone SSC	
M40494	Wrench kit for maintenance and spoke tension on the wheels: Crossmax™ UST, Crossmax™ XL and Crossmax™ SL Crossmax™ UST Disc, Crossmax™ XL Disc and Crossmax™ SL Disc Ksyrium™ SSC and Ksyrium™ SSC SL.	
M40567	Wrench for aerodynamic spokes.	
M40652	Zamac wrench for adjusting spokes on the wheels: Crossmax™ UST, Crossmax™ XL and Crossmax™ SL Crossmax™ UST Disc, Crossmax™ XL Disc and Crossmax™ SL Disc Ksyrium™ SSC and Ksyrium™ SSC SL	
M40630	Wrench for adjusting screwed eyelets on the wheels : Deemax® UST , Crossroc™, Crossroc™ Disc, Ksyrium Elite and on the rims D3.1 Disc , X3.1 Disc and X3.1 .	
M40123	Hub wrench for adjusting the free play on Mavic® hubs, except Crossroc™ and Crossroc™ Disc.	
M40122	Mavic® mineral oil for lubricating the FTS and FTS-L free wheel bodies Capacity 60 ml.	
M40315	Mavic® thread lock.	

GENERAL PROCEDURE FOR ANY REQUEST FOR SERVICE SUPPORT

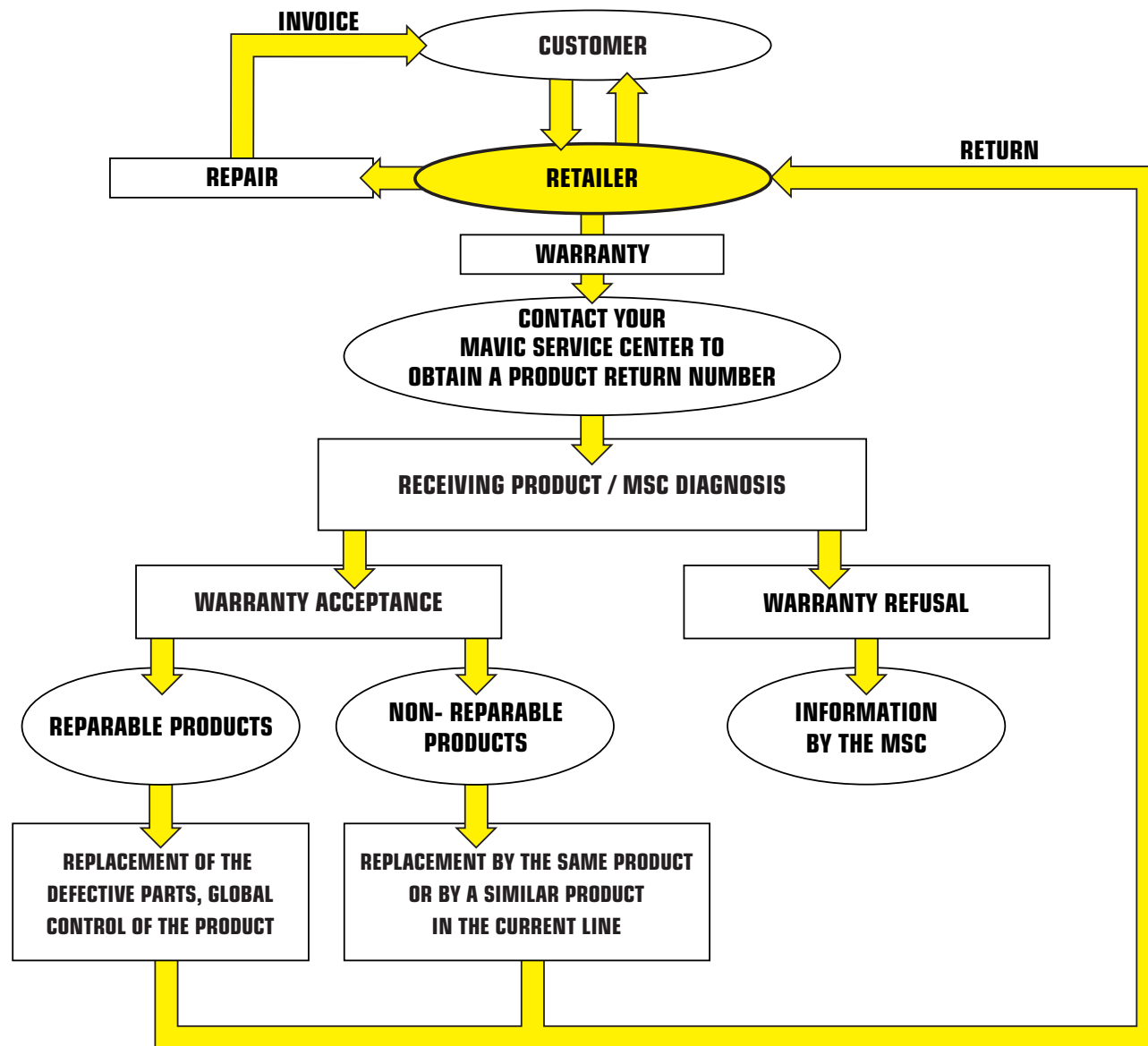

- 1** Contact the Mavic® Service Center in your geographical zone to obtain a **PRODUCT RETURN** number.
- 2** Follow the directions given from your Mavic® Service Center, send the damaged part or product directly to them with a note containing the following information :
 - Your name and address
 - The product return number that was given to you. This number should also be indicated on the outside of your package.
 - Reason for return.
 - **Proof of date of purchase attesting that the product was sold within the last 2 years (receipt or warranty card filled out).**

CAUTION : The wheels must be sent without the tire, cassette, skewer, bag, or anything else in order to avoid any risk of loss or damage.
To be able to process your request as quickly as possible, we request that you follow this procedure. ANY OTHER TYPE OF RETURN WILL BE REFUSED.
- 3** After the Mavic® Service Center receives your package, it will make a diagnosis and will declare whether the damaged product will be covered by the warranty or not. Then, the product will be exchanged or repaired.
 NB. : If the warranty is refused, your Mavic® Service Center will inform you about the cost of the repair.
 If the product cannot be repaired, the Mavic® product will be destroyed after acceptance by the customer.
 If you decide to repair the Mavic® product yourself, please read the preceding pages.

Your Mavic® Service Center is available for information regarding repairs and the Mavic® warranty. Please do not hesitate to contact them.

MAVIC® WARRANTY AND CUSTOMER SERVICE

MAVIC® WARRANTY

Mavic® products are guaranteed against manufacturing and material defects for a period of 2 years from the date of original purchase.

OBLIGATIONS

Mavic® will replace or repair the product or the part considered to be defective by Mavic®. This is Mavic's only liability. Complementary warranties may exist according to regional laws.

LIMITATIONS

This warranty does not apply to damage or defects resulting from misuse in shipping, storage (accidents, negligence, shocks, or falls), failure to follow the instructions for use, improper installation or installation with incompatible products, poor maintenance or normal wear and tear, abnormal or improper use, modification or alteration of the product.

This warranty does not cover parts that can wear down such as rims (with rim braking system), brake pads, rear derailleur jockey wheels, ...

This warranty does not cover products whose repair has not been authorized by Mavic® Customer Service or its representative in certain countries (1).

This warranty does not cover any product whose item number or identification has deteriorated or been removed.

This warranty does not apply to "Mavic® Special Service Race " (2) or sponsorship products.

APPLICATION PROCEDURE

Retailers-dealers are authorized and responsible to manage all claims under the warranty. Retailers-dealers must obtain an authorization from Mavic® Customer Service (or its representative in certain countries (1)) prior to returning the defective product (3).

The complete product with proof and date of purchase (receipt, copy of the warranty card...) has to be sent by the retailer-dealer to Mavic® Customer Service (or its representative in certain countries (1)) who will ensure the proper procedures.

The new or repaired product will be returned to the retailer-dealer.

WARRANTY CARD

The customer should save the warranty card for use in claims.

(1) Updated lists are available upon request at : Mavic® - 74996 Annecy Cedex 09 or on the Mavic® website: <http://www.mavic.com>.

(2) Products engraved with "SSC®" or for which the serial numbers have been used by the "Mavic® Race Department".

(3) Any claims made by any other means or without prior agreement for the return cannot be taken into account.

TO CONTACT YOUR MAVIC® SERVICE CENTER

COUNTRY	TELEPHONE	FAX
MSC AUSTRALIA	(+61) 039 888 9882	(+61) 039 888 9902
MSC AUSTRIA	(+43) 066 2636 24519	(+43) 066 2636 2455
MSC BENELUX	(+32) 01 434 7470	(+32) 01 432 39 04
MSC CANADA EAST	(+1-514) 332 1320 or 1-800 363 0693	(+1-514) 335 1691
MSC CANADA WEST	(+1-604) 324 6900 or 1-800 363 0693	(+1-604) 258 9343
MSC CZECH REPUBLIC	(+420) 616 624 336	(+420) 616 626 240
MSC FRANCE	(+33) 04 50 65 72 81	(+33) 04 50 65 71 45
MSC GERMANY	(+49) 08033 305163	(+49) 08033 305169
MSC HOLLAND	(+31) 049334 1674	(+31) 049334 2550
MSC ITALY	(+39) 03 5499 3975	(+39) 03 5499 3912
MSC JAPAN	(+81) 04 8997 4501	(+81) 04 8997 2701
MSC NEW ZEALAND	(+64) 4 528 3608	(+64) 4 528 3601
MSC POLAND	(+48) 07137 21 570 or (+48) 07132 19 690	(+48) 07132 78 092
MSC SPAIN	(+34) 09 36 34 06 30	(+34) 09 36 34 12 91
MSC SWITZERLAND	(+41) 02 6677 2226	(+41) 02 6677 1971
MSC UK	(+33) 04 50 65 72 88	(33) 4 50 65 71 45
MSC USA	(+1-888) 466 28 42	(+1-978) 373 1113

MAVIC® SA
Metz Tessy
74996 Anancy Cedex 9
Tel: (+33) 04 50 65 71 71
Fax : (+33) 04 50 65 71 96

GERMANY
 Mavic Vertretung
 Geigelsteinstrasse 10
 83080 Oberaudorf
 Tel: (+49) 08033 305 210
 Fax : (+49) 08033 305 199
 Bestell-Hotline
 Tel: (+49) 08033 305 200
 Fax : (+49) 08033 305 299

AUSTRALIA
GROUPE SPORTIF
PTY LTD
 20 Harker Street
 Burwood, Victoria 3125
 Tel: (+61) 03 9888 9882
 Fax : (+61) 03 9888 9902

AUSTRIA
FUNBIKE
 Salzachweg 1
 5061 Salzburg-Elbethen
 Tel: (+43) 0662 636245 19
 Fax : (+43) 0662 636245 5

BENELUX
CODAGEX
 Zanbergen 10
 2480 Dessel Belgium
 Tel: (+32) 014 34 74 74
 Fax : (+32) 014 32 39 04

CANADA
OUTDOOR GEAR DIST.
 2708 Diab -
 Ville St Laurent,
 QC H54 1E8
 Tel: (+1-514) 332 1320
 Fax : (+1-514) 335 1691

SPAIN
EUROBIKE
 Ave. Can Lluçh 23-25
 08690 Sta Coloma Cervello
 Tel: (+34) 09 36 34 06 30
 Fax : (+34) 09 36 34 12 91

FRANCE
MAVIC
 Metz Tessy
 74996 Anancy Cedex 9
 Tel: (+33) 04 50 65 71 71
 Fax : (+33) 04 50 65 71 96

ITALY
VITTORIA
 Via Papa Giovanni XXIII, 1
 24040 Madone (BG)
 Tel: (+39) 035 499 39 11
 Fax : (+39) 035 499 39 12

JAPAN
MAVIC
 2-1-14 Sarugaku-cho
 Chiyoda Ku
 Tokyo 101 - 0064
 Tel: (+81) 3 5281 7166
 Fax : (+81) 3 5281 7167

NEW ZEALAND
CYCLES ETC
 151 Neilson Street
 Onehunga - Auckland
 Tel: (+64) 4 528 3608
 Fax : (+64) 4 528 3601

CZECH REPUBLIC
KASTAR
 Brodska 10
 CZ 591 01 Zdar n/Sazavou
 Tel: (+420) 616 624 336
 Fax : (+420) 616 626 240

SWITZERLAND
LOUP SPORT
 1587 Montmagny
 Tel: (+41) 026 677 22 26
 Fax : (+41) 026 677 19 71

U.S.A.
MAVIC INC
 17 Parkridge Road
 Haverhill, MA 01835
 Tel: (+1-888) 466 28 42
 Fax : (+1-978) 373 1113

www.tech-mavic.com



**TECHNICAL
 MANUAL**



03

Printed in France © MAVIC® S.A.

Groupe adidas Salomon - 2002

All rights reserved RCS Anancy 379 696 255 - 00056 - APE 364 Z - Limited company with a capital of 8.280.000 €.

This document is not legally binding. MAVIC® S.A. reserves the right not to sell all products in certain countries and to effect any useful or necessary changes. All rights reserved. Reproduction prohibited - Indicated wheel weights +/- 5 %, without rim tape, or quick release skewer but with valve for the Tubeless wheels on the industrial pre-series models. Rim weight +/- 10 %. Carefully read the recommendations for rim use inside.

Photos : Didier Brandelet - Blue / Eric Leprince.

Design graphic : Eric Leprince - Sébastien Bouvier / Realisation : Didier Brandelet - Blue.

