



SAN ANDREAS



MOHO CXS



MOHO STS

MOUNTAIN CYCLE

www.MOUNTAINCYCLE.COM

2494 Victoria Avenue
San Luis Obispo, CA 93401
tel. 805.545.8004 fax. 805.545.9790
VOL II 1999

fold here

Return Address:

Place
Stamp
Here



To: Mountain Cycle™
2494 Victoria Avenue
San Luis Obispo, CA 93401
USA

TABLE OF CONTENTS

INTRODUCTION 3
INSERT STEERER STOP INSTRUCTIONS 4
 Installation 5
 Positioning 5
 Bolt Selection 6
 Maintenance 6
 A Note on Loctite 6
SANANDREAS™ ADJUSTMENTS 7
 Subframe Adjustment 7
 Rear Wheel Travel Adjustment 8
 Head Angle Adjustment 8
 Shock Selection 9
 San Andreas Maintenance 9
SANANDREAS™ SPECIFICATIONS 10
 Figure 1 - San andreas™ 10
 Table 1 - San andreas™ Specifications 10
SANANDREAS™ DHS SPECIFICATIONS 11
 Figure 2 - San andreas™ DHS 11
 Table 2 - San andreas™ DHS SPECIFICATIONS 11
MOHO™ STS “SOFTAIL” & MOHO™ CXS 12
 MOHO™ STS & MOHO™ CXS Framesets features: 12
 MOHO™ CXS Maintenance: 12
MOHO™ STS SPECIFICATIONS 13
 Figure 3 - MOHO™ STS 13
 Table 3 - MOHO™ Specifications 13
MOHO™ CXS SPECIFICATIONS 14
 Figure 4 - MOHO™ CXS 14
 Table 4 - MOHO™ CXS Specifications 14
AFTERSHOCK™ INSTRUCTIONS 15
 Fine Tuning: Aftershock™ 15
 Figure 5 - AfterShock™ Spring Changing Instructions 15
SHIMANO DERAILLEUR COMPATIBILITY 16
 Table 5: Chain ring size 16
MOUNTAIN CYCLE™ ACCESSORIES 17
WARRANTY 18
CUSTOMER RESPONSIBILITY 19
 Warranty Exclusions 19
MOUNTAIN CYCLE™ PRODUCTS 20 - 21
ORDER FORM 22
WARRANTY REGISTRATION CARD 23

WARRANTY REGISTRATION CARD

First Name: _____ MI: ____ Last Name: _____

Age: _____ Male: _____ Female: _____

Address: _____

Telephone: (____) _____ - _____ Fax: (____) _____ - _____

Dealer Name: _____

Dealer Address: _____

How did you hear about Mountain Cycle™ products? _____

_____ Dealer _____ Magazine _____ Internet _____ Other

What magazines do you read regularly?:

- Mountain Biking Velo News Bicycling
 Mountain Bike Mt. Biker Norba News
 Mountain Bike Action Other

What new products would you like to see? _____

What is your reason for choosing a Mountain Cycle™ Product:

- Friends Product performance Cost
 Suspension Frameset Style & Design Other

Do you own other full suspension frames? Yes No

Do you plan to purchase a:

- Disc Brake Kit: Front Rear
 Suspension Frameset
 “Softail” Frameset

Do you:

- Race? Dual Slalom? Cross Country:
 Downhill? Road? Attend Races?

Are you NORBA Registered? Yes No

How many bicycles do you own?

Mountain _____ Road _____ BMX _____

Purchase price (US\$) _____

Do you have front suspension? _____ What brand? _____

Rock Shox _____ Manitou _____ Other _____

Would you be interested more in a:

Mountain Cycle™ Frameset _____ Complete bike by Mountain Cycle™

Comments: _____

ORDER FORM

	DESCRIPTION	SIZE	COLOR	QTY.	PRICE EACH	AMOUNT
1	Mountain Cycle Jersey (xs, s, m, l, xl, xxl)				\$52.00	
2	Mountain Cycle Jacket (xs, s, m, l, xl, xxl)				\$59.00	
3	Mountain Cycle Bike shorts (xs, s, m, l, xl)				\$45.00	
4	Mountain Cycle Cotton T-shirts. Available in only in white (m, l, xl)				\$16.00	
5	ProStop Cotton T-shirt. Available only in white (m, l, xl)				\$16.00	
6	Mountain Cycle Hat's - Embroidered logo (one size)				\$18.00	
7	ProStop Hat's - Embroidered logo (one size)				\$18.00	
8	ProStop Disc Brake Kit				Prices vary, call for pricing	
9	Sticker Kit				\$14.00	
10	Mountain Cycle logo mugs				\$8.00	
11	Mountain Cycle hub salt & pepper shakers				\$29.00	

(A 10% discount will be given to orders received with frame registration.)

Total, minus 10% with frame registration

CA Residents add 7.25% sales tax

Add: Shipping & Handling

Total

Enclose Check or
Money Order Payable to:

Mountain Cycle
2494 Victoria Ave.
San Luis Obispo, CA 93401

Please allow 2 to 4 weeks for processing and delivery.

Mailing Label: Please Print

Name: _____

Street: _____

City: _____ State: _____

Zip Code: _____ Tel: () _____

Method of Payment: () Check / Money Order _____
() Visa () MasterCard

Credit Card No.: _____

Card Type: _____ Expiration Date: _____

OR ORDER FROM OUR WEBSITE: WWW.MOUNTAINCYCLE.COM

CONGRATULATIONS!

The San Andreas™, San Andreas™ DHS, MOHO™ CXS fully suspended framesets and the MOHO™ STS “Softail” are three of the most sophisticated bicycle systems ever designed. Our engineers have spent countless hours innovating and perfecting concepts that you will find on no other framesets. Concepts driven by the desire to create bicycles that withstand the rigors of racing, as well as enhance your everyday riding. The San Andreas™, MOHO™ CXS, and the MOHO™ framesets are the results of that desire. We are confident that your Mountain Cycle™ products will greatly enhance your riding pleasure and performance.

All Mountain Cycle™ framesets are manufactured from HMI/Monocoque 6061-T6 Aluminum, and incorporate a Delta Box/HMI-Monocoque design that increases strength and eliminates flex while providing superior handling characteristics. All framesets include the new Mountain Cycle™ lightweight S-series aluminum seatpost collar. New for 2000 is the Mountain Cycle Original Universal Steerer Stop System, found on the MOHO STS, MOHO CXS, and the San Andreas framesets. This system prevents damage from the use of double triple clamp fork setups, which can cause quite nasty dents in crash situations.

The San Andreas™ with its Monocoque Swingarm provides optimum rear wheel traction with neutral, “anti-squat” performance. The Delta Box Mainframe provides great rigidity at the headtube and bottom bracket. The San Andreas’s modular design allows for varying rear wheel travel (42.2-43.7”) and customizable rider cockpit area.

The MOHO™ STS “Softail” frameset features a Delta Box/Monocoque Mainframe which transitions to larger diameter tubes for superior stiffness. The square tubing used in the rear triangle increases the frame rigidity, while the CNC wishbone coupled with the monostay provide a modicum of shock dampening, leading to a smoother, “softer” ride. The MOHO™ is available in Off-Road, Road and Triathlon versions.

The MOHO™ CXS is a fully suspended frameset featuring 3.75” of rear wheel travel. The frame’s four bar linkage is specifically designed to have an exceptionally laterally rigid rear end, with the utmost rigidity in the front from its monocoque front triangle. This frame has an exceptionally “neutral” feel and has performance unequalled by any cross-country frame available on the market today. Every pivot is fully scaled and greaseable, assuring the frame a long life when properly maintained.

Although the San Andreas™ and MOHO™ framesets come with the main components assembled, this document includes step by step instructions for the setup, adjustment, and maintenance of each component, as options may require.

WARRANTY

** Please fill out the warranty registration card and return to Mountain Cycle™ immediately. Warranty registration form provided with this manual must be filled out and returned to Mountain Cycle™ within 30 days of purchase or your warranty is void.



UNIVERSAL STEERER STOP

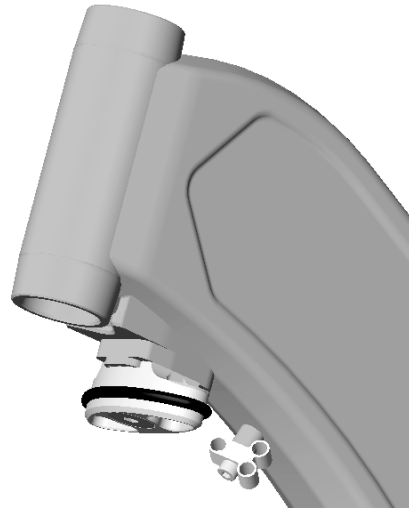

Mountain Cycle™ is continuing our forefront technology with the introduction of the Universal Steerer Stop System. For the first time in the bicycle industry, reliable protection from double-triple clamp fork damage is available for virtually every fork on the market. In 1996, Mountain Cycle™ introduced the first steerer stop with the San Andreas™ DHS frameset, which was compatible with Risse and Mr. Dirt forks. This innovation is now available on all our framesets: the ShockWave™, the San Andreas™, the San Andreas™ DHS, the MOHO™ STS, the MOHO™ CXS, and the AfterShock™ BMX.

As the proud owner of a Mountain Cycle™ frameset, you demand the best for racing performance. We at Mountain Cycle™ know this, we also know that practice makes perfect. With this in mind, we have designed the Universal Steerer Stop System to make sure that the unavoidable crash doesn't harm more than your pride. This system provides:

- ⚡ Bullet proof protection from frame damage due to double-triple clamp fork collisions
- ⚡ "Rubber Bumper Collision System" protects against marring of fork crown
- ⚡ Compatibility with most manufacturers: Answer, Bullet, Hanebrink, Marzocchi, Risse, RST, Stratos and White Bros.
- ⚡ Adjustability to accommodate new and different designs

MUGS
\$8 USD



STICKER KITS
\$14 USD



AVAILABLE DIRECT FROM MOUNTAIN CYCLE (see enclosed form)

OR VISIT OUR WEBSITE: www.MountainCycle.com

(A 10% discount will be given to orders received with frame registration.)

JERSEYS
\$52 USD



JACKET
\$59 USD

SHORTS
\$45 USD



Mountain
Cycle™
HATS
\$18 USD

ProStop™
T-SHIRTS
\$16 USD



ProStop™
HATS
\$18 USD

Mountain
Cycle™
T-SHIRTS
\$16 USD



ProStop™
DISC BRAKE
KITS
Prices Vary

INSTALLATION

For Installation, you will need the following tools:
6mm Allen Wrench
Blue Loctite
That's it.

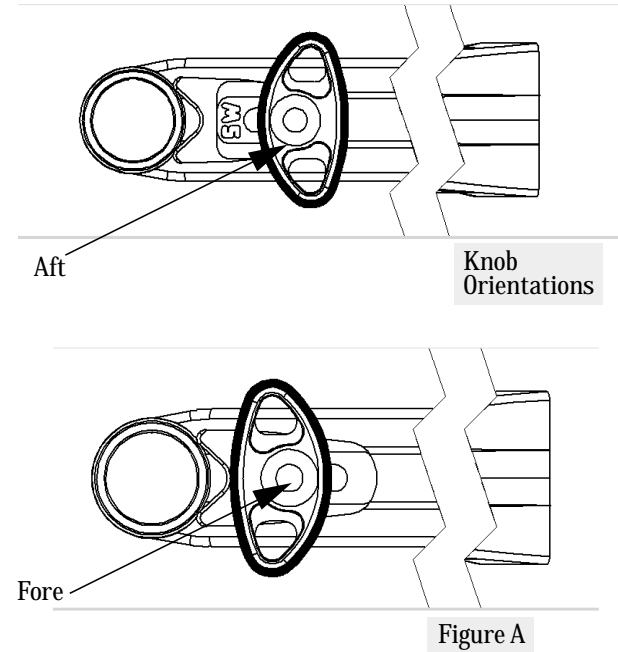

POSITIONING

The Universal Steerer Stop System has been designed to accommodate varying fork crown profiles. There are three modes of adjustability:

1. Fore/Aft mounting Position (Fig. A)
 2. Steerer Stop Knob Orientation (Fig A)
 3. Steerer Stop Knob Height Adjustment (with 1/4" Spacer) (Fig. B, page 6)
- The combination of the above adjustability features will depend on the profile of the lower crown of the fork you have chosen. There are two guidelines you must follow when installing the system to ensure optimum protection. They are:

- Use the spacer in order to locate the “contact patch” as close to the middle of the height of the crown (Fig C, page 6)
- Use the Fore or Aft Hole position combined with the Knob Orientation to provide maximum turning radius while preventing fork contact with the frame. (If any part of the fork comes into contact with the frame, the stop is not installed properly and severe damage can occur.)

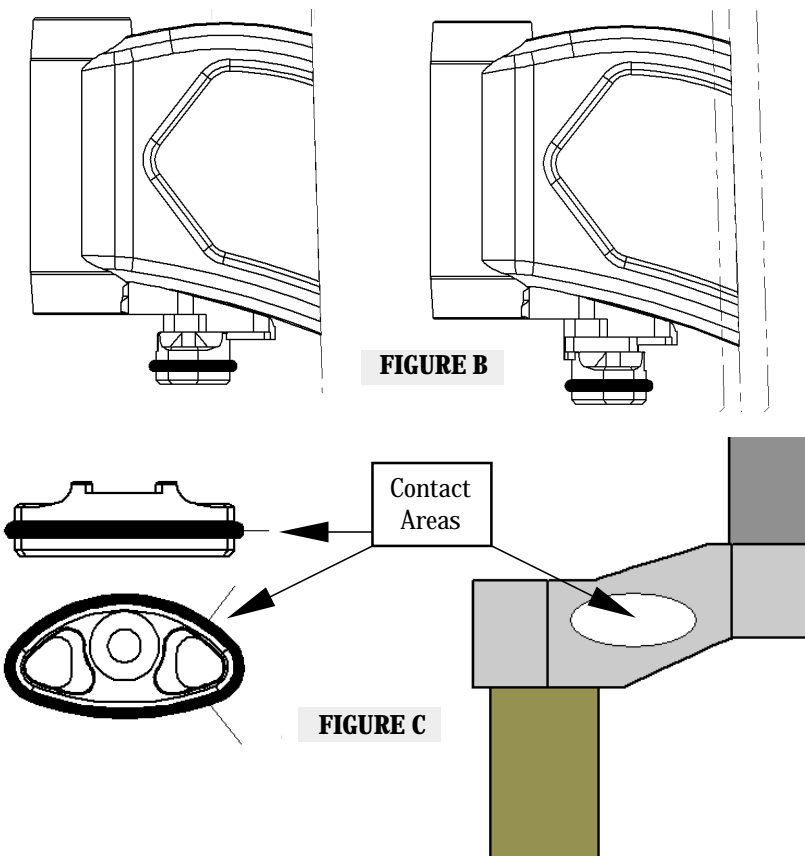

FIGURE B

FIGURE C

BOLT SELECTION

Three CounterSunk Cap Screws have been included with your kit. This is to accommodate differences in thread depth due to hole position, and use of the spacer unit. Use the screw that assures maximum thread engagement without hitting the bottom of the thread hole.

MAINTENANCE

As with all your components, you should periodically check for any crash damage and loosening of screws. If you have a screw loose, tighten it. If your Steerer Stop Knob shows any signs of damage, contact Mountain Cycle™ for a professional appraisal.

A NOTE ON LOCTITE









It is very important that Blue Loctite (or a commercial substitute) is used on the screw that holds the Steerer Stop Knob in place. Without Loctite, screws may come loose and rattle out at the most inconvenient times (such as at the top of a drop off or at very high speeds.)



CUSTOMER RESPONSIBILITY

All warranties are subject to the consumer following maintenance guidelines as specified for Individual Mountain Cycle™/ProStop™ products. Any modification made by the user to Mountain Cycle™/ProStop™ products will render the warranty null and void.

WARRANTY EXCLUSIONS

-  This warranty covers only the original retail purchaser of the frameset or product and is not transferable.
-  This warranty does not cover failure due to accident, abuse, misuse, neglect, normal wear and tear, and frame fading or rust, improper assembly, improper fit, improper maintenance or use of unauthorized parts.
-  This warranty does not cover any personal injuries, damage, failure of bicycle used in any competitive event, including bicycle racing, bicycle motocross, stunt or similar activities or accessories inconsistent with the use intended by Mountain Cycle™ will negate this warranty.
-  This warranty does not cover failure due to unlawful acts.
-  This warranty is void when the bicycle is used by many and unspecified persons such as rent-a-bicycle businesses.
-  This warranty is void when the Mountain Cycle™/ProStop™ products are used for racing purposes.
-  This warranty does not cover natural phenomena, which result from operation of the bicycle such as vibrations or sounds.
-  This warranty is void when maintenance items outlined by Mountain Cycle™/ProStop™ are not followed.
-  This warranty is void if the frameset is powder coated after leaving the factory.

Important Note: Some Mountain Cycle™/ProStop™ products are designed for Off-Road use only. They may not conform to State and Federal vehicle safety standards for operation on public streets, roads or highways in your area and may be illegal. It is your responsibility to check your state and local laws, rules and regulations.



WARRANTY POLICY**Limited Five (5) Year Warranty**

For the Original Owner, from the date of sale, any Mountain Cycle™/ProStop™ product found by the factory to be defective in materials and/or workmanship within the specified time limit, will be repaired or replaced at the option of the Manufacturer, free of charge, except for shipping or dealer labor charges (if applicable) when received at the factory, freight paid. This specified time period includes (1) year of full coverage against any defect in materials and/or workmanship, not including the exclusions listed below. From years (2-5) Mountain Cycle™ will offer a prorated replacement-pricing schedule according to the item and its age. This warranty does not include wearing parts (brake pads, rotors, screws, nuts, etc.) Warranty does not include items specified in warranty exclusion.

This warranty is expressly in lieu of all other warranties, and any implied warranties of merchantability of fitness for a particular purpose created hereby, are limited in duration to the same duration as the expressed warranty herein. Mountain Cycle™ shall not be liable for any incidental or consequential damages. Some states do not allow for the exclusion or limitation of implied warranties, incidental or consequential damages, so the limitations and exclusions may not apply to you.

This Warranty gives you specific legal rights, and you may also have other rights, which vary from state to state.

All claims made under this warranty must be made to Mountain Cycle™ or a authorized Mountain Cycle™ dealer during the relevant warranty period. To obtain warranty service, the owner must contact Mountain Cycle™ to obtain a return authorization number. No returns will be accepted without a return authorization number. Please take the time to complete the questionnaire on page 15. The information you provide will validate your San Andreas™ Frameset Warranty and help Mountain Cycle™ to provide you with the products and service that will make your cycling safer and more enjoyable.

Return of this warranty registration card to Mountain Cycle™ is a condition precedent to coverage under the Frameset Warranty. Failure to return this card will result in the expiration of this warranty.

SAN ANDREAS™

The Mountain Cycle™ San Andreas™, the undisputed king of the freeride kingdom, has been improved to offer more features and adjustability than ever before! In 1991, the San Andreas™ was introduced as the very first mountain bike to offer long-travel suspension, coupled with front and rear disc brakes. Then, in 1995, the San Andreas™ DHS was introduced for the serious downhill, with over 6 inches of rear wheel travel. For 1999, the San Andreas™ combines both cross country, freeride, and downhill into one spectacular package. With one frameset: rear wheel travel can be set from 4 1/2 inches to over 6 inches, head angle can be set from between 72° and 67° and the rider cockpit area is customizable.

Due to the limit a suspension frameset can put on component placement, some styles of front derailleur will not work with your San Andreas™ Please refer to Table 1 (page 10) to determine which model you will need.

HOW DO I ADJUST THESE FEATURES?

The major change of the San Andreas™ revolves around the Subframe/Shock Mount pictured at the right. This piece controls all your adjustments.

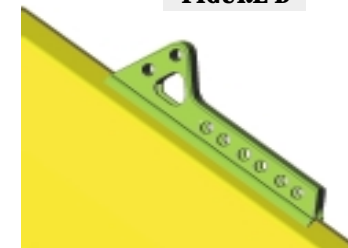
FIGURE D**SUBFRAME ADJUSTMENT**

The rider cockpit is customizable in many ways. Stem, seat size and position, and seat post all depend on a rider's preference. The San Andreas™ also incorporates an adjustable seat tower to allow the rider to vary the effective top tube length and center of gravity over the frame.

As illustrated by Figure E, the Subframe nose mounts in two positions, the Forward position and the Rear position. This offers two effective top tube lengths. The San Andreas™ also has two subframe sizes, Small and Standard. This combination adds up to four different sizes from one frameset. (All actual geometry numbers and descriptions can be found in your owner's manual at the end of this instructional packet.)

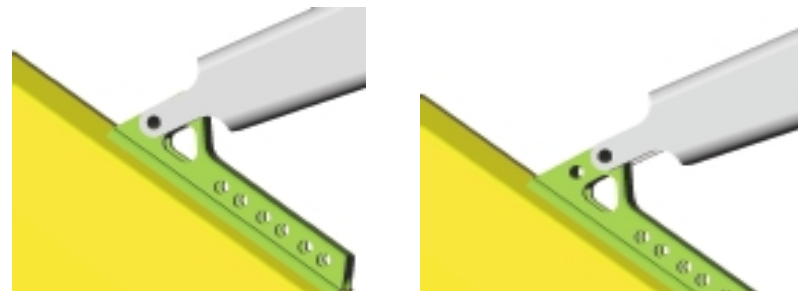
FIGURE E**Forward****Rear**

REAR WHEEL TRAVEL ADJUSTMENT

Rear wheel travel is adjustable from 4 1/2 to 6 inches by changing shocks. The stock Mountain Cycle™ AfterShock™ offers 4 1/2 inches of travel with compression adjustment. By using a Stratos Helix Pro, travel can be extended to 6 inches. (Please see the section entitled “Shock Selection” (page 9) for available shock options.)

FIGURE F

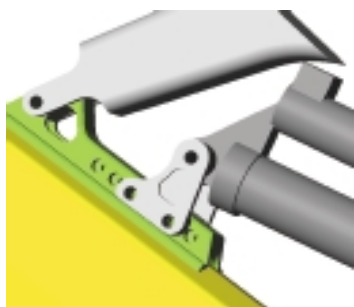

AfterShock

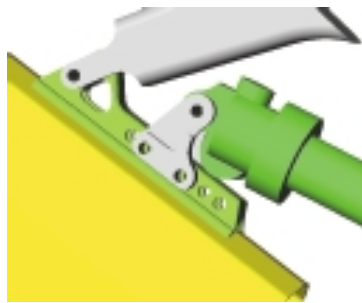

Stratos Helix Pro

HEAD ANGLE ADJUSTMENT

The head angle of the San Andreas™ varies greatly with fork selection. Forks are available with travel varying from 2 1/2 all the way to 9 inches. This will affect your headtube angle (and ride height) drastically. The San Andreas™ does offer some fine-tuning. As seen in Figure G (illustrated in the long travel position) the shock mount plates have two positions (for each shock selection.) The position shown in the left of Figure G (“tight”) is the position that will give a steeper head angle. By switching to the position shown in the right of Figure G (“slack”) drops the headtube angle by approximately 2°. (Actual angles will depend on fork and tire combinations, and will vary greatly with preference of static sag.)

FIGURE G

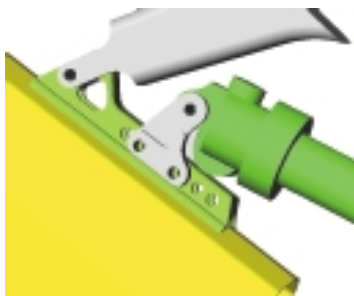

“tight”

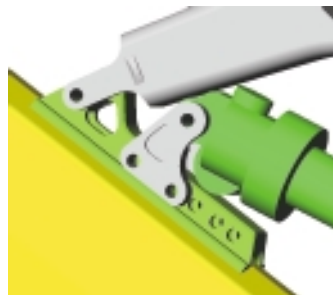

“slack”

ACCESSORIES

Look for these and other Mountain Cycle™ products available through the world wide web (www.MountainCycle.com) or your local authorized dealer.

Framesets:

- ||- MOHO™ (ROAD, CXS, STS, TRI)
- ||- SAN ANDREAS™ and SAN ANDREAS™ DHS
- ||- AfterShock™ BMX

Shocks:

- ||- Mountain Cycle™ AfterShock™ (Alternate Spring Rates Available.)
- ||- Fox Shocks
- ||- Risse Racing Air/Oil Shock - Standard or Long Travel
- ||- Stratos Shocks

Brake Parts:

- ||- ProStop™ Brake Mounting Kits for MOHO™ CXS and AfterShock™ Frameset

Clothing:

- ||- Shop Aprons
- ||- T-shirts
- ||- Hats
- ||- Sweatshirts
- ||- Racing Jerseys
- ||- Jackets

Miscellaneous:

- ||- Frame Decal Kits
- ||- ProStop™ & International Disc Brake Mounts for MOHO™ STS and MOHO™ CXS
- ||- Universal Chainguide for San Andreas™, MOHO™ CXS and MOHO™ STS: 38-48 tooth chainring capacity.
- ||- Mountain Cycle™ logo mugs
- ||- ProStop™ logo wheel, hub salt & pepper shakers.

**TABLE 5
CHAIN RING SIZE**

	MODEL	STYLE	48T	46T	44T	42T
SAN ANDREAS™						
XTR	FD-M901	Top Swing	◆	◆		
	FD-M950	Conv.	☑	☑		
XT	FD-M739	Top Swing	◆	◆	◆	◆
	FD-M738	Conv.	☑	☑	☑	☑
LX	FD-M567	Top Swing			◆	◆
	FD-M566	Conv.			☑	☑
MOHO™ CXS						
XTR	FD-M901	Top Swing	◆	◆		
	FD-M950	Conv.	☑	☑		
XT	FD-M739	Top Swing	◆	◆	◆	◆
	FD-M738	Conv.	☑	☑	☑	◆
LX	FD-M567	Top Swing			◆	◆
	FD-M566	Conv.			☑	◆
MOHO™						
XTR	FD-M901	Top Swing	☑	☑		
	FD-M950	Conv.	☑	☑		
XT	FD-M739	Top Swing	☑	☑	☑	☑
	FD-M738	Conv.	☑	☑	☑	☑
LX	FD-M567	Top Swing			☑	☑
	FD-M566	Conv.			☑	☑

☑ Compatible
◆ Not recommended

SHOCK SELECTION

The San Andreas™ 1999 has been designed to work around certain shocks. Due to geometric differences between shocks and design constraints, only Mountain Cycle™ approved shocks can be used with your San Andreas™ frame. Use of unapproved shocks will void your warranty, and could cause serious or fatal injury.

Rear wheel travel is dependent on shock length and shock stroke. A 7 1/2 inch eye to eye length shock will give over 6 inches of rear wheel travel, while a 6 1/8 inch eye to eye length shock will give 4 1/2 inches. The mounting specifications and compatibility are listed below:

7 1/2" SHOCK

Make/Model	Stroke	Bottom Spacing	Top Spacing
Stratos Helix Pro	2.0-2.25"	0.650"	1.25" (0.860")
Stratos Helix Expert	2.0-2.25"	0.650"	1.25" (0.860")
Fox Vanilla R	2.0"	0.650"	1.25" (0.860")

6 1/8" SHOCK

Make/Model	Stroke	Bottom Spacing	Top Spacing
MC AfterShock	1.5"	0.650"	1.25" (0.860")
Stratos Helix Pro	1.5"	0.650"	1.25" (0.860")
Stratos Helix Expert	1.5"	0.650"	1.25" (0.860")
Fox Vanilla R	1.5"	0.650"	1.25" (0.860")

**Note: All replacement/upgrade shocks must be purchased through a Mountain Cycle authorized dealer.

SAN ANDREAS™ MAINTENANCE:

Swingarm Pivot Bearing

The Swingarm Pivot Bearing on your San Andreas™ will need to be periodically lubricated depending on the frequency and severity of your riding.

In order to lubricate the bearing properly you will need high quality grease that is compatibility with plastic bearings. Remove the pivot shaft end caps and inspect for the grease port. It is a small hole on one side of the pivot shaft. Insert the applicator tip of a grease gun into the pivot shaft until it reaches the grease hole. Pump grease into the bearing until you see the grease escape from the outer edge of the bearing seal. Remove applicator and wipe off excess grease from surrounding area. Perform this procedure monthly or weekly as may be needed.

To remove any mud, grease or foreign matter from the frameset, spray lightly with a mild cleaner (Formula 409 or Simple Green) and rinse off using a gentle stream of water. Dry immediately with soft towel or cloth.

WARNING! *Do not* use solvents or harsh abrasives to clean any part of the San Andreas™ frameset.



FIGURE 1- SAN ANDREAS™

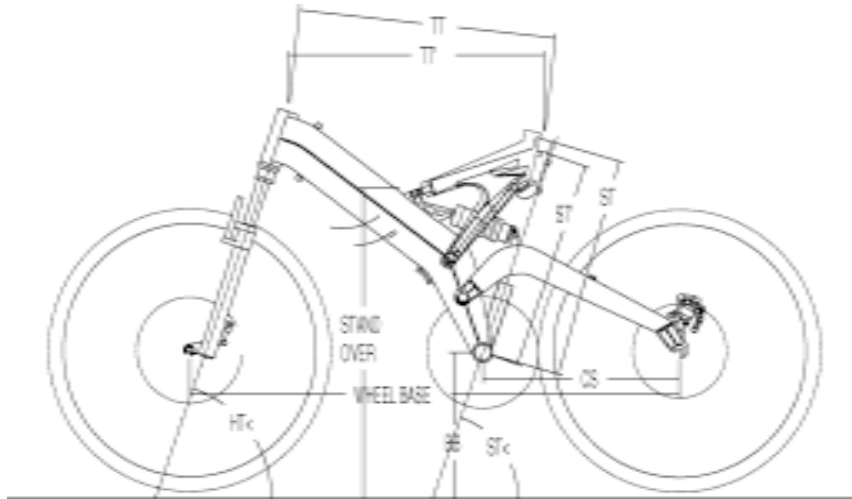

**TABLE 1 - SAN ANDREAS™ SPECIFICATIONS
SEE FIGURE 1**

(English)	SMALL	REGULAR	(Metric)	SMALL	REGULAR
TT	21.9/20.9	23.0/22.3	TT	55.6/53.1	58.2/55.6
TT'	21.8/20.8	22.8/21.8	TT'	55.4/52.8	57.9/55.4
ST	18.8/19.2	19.5/19.9	ST	47.8/48.8	49.5/50.5
ST'	17.8/18.0	18.4/19.0	ST'	45.2/45.7	46.7/48.3
Wheelbase	42.2/43.5	42.2/43.5	Wheelbase	107.2/110.5	107.2/110.5
BB	12.7/13.3	12.7/13.3	BB	32.3/33.8	32.3/33.8
CS	17/16.7	17/16.7	CS	43.2/42.4	43.2/42.4
ST°	71.2°/69.8°	69.6°/68.4°	ST°	71.2°/69.8°	69.6°/68.4°
	76.3°/74.9°	75.2°/73.8°		76.3°/74.9°	75.2°/73.8°
HT°	68.5°/70°	68.5°/70°	HT°	68.5°/70°	68.5°/70°
Standover	27.5/27.2	27.5/27.2	Standover	69.9/69.1	69.9/69.1

Derailleur Mount Tube = 31.75mm

NOTE: TT, TT', ST, ST' adjusted by moving the subframe position (rear/forward)

Wheelbase, BB, CS, ST°, HT° and Standover adjusted by moving the shock mounting position (rear/forward)

FINE TUNING: AFTERSHOCK™

Your rear shock can be fine tuned by making simple adjustments to the pre-road adjustment screw on the shock body. Adjustment is achieved by turning the preload adjuster clockwise to stiffen the shock or counterclockwise to soften it.

FIGURE 5 - AFTERSHOCK™ SPRING CHANGING INSTRUCTIONS

Step 1: Take Aftershock™ in hand and turn spring retaining collar until it reaches the base position.



Step 2: Slide retaining cap inward to expose the flat portion of the spring end.



Step 3: Place the flat edge of the spring against the edge of your workbench or table

Hint: Placing a rag between the spring and table will prevent both from scratching.

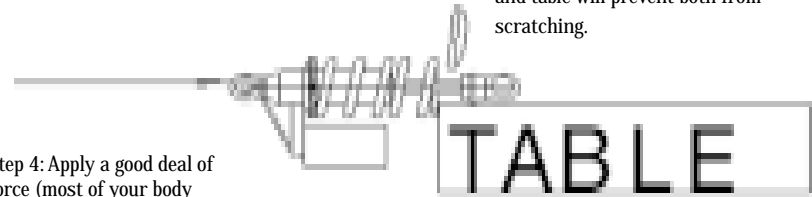

Step 4: Apply a good deal of force (most of your body weight) against the shock end. As the spring compresses, the plate will be free to remove.

Step 5 Remove old spring, and place new spring in it's place.



Step 7: Once again, apply force to the end of the shock. As the spring compresses, the retaining cap will slide further.

Step 6: Place retaining cap as shown. Leave the flat portion of the spring exposed.

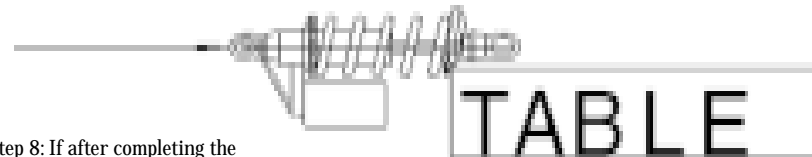

Step 8: If after completing the above steps. The retaining cap is still not in place, flip it over, and give the edge a good whack. It should pop into place.

Hint: (A cloth will still prevent scratching.)

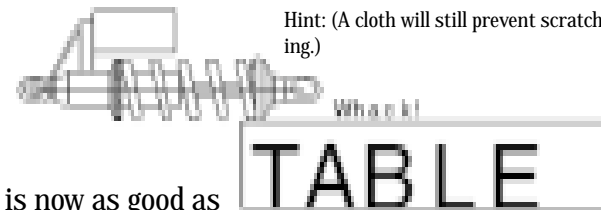

Your Aftershock™ is now as good as new mount it up and go ride!

FIGURE 4 - MOHO™ CXS

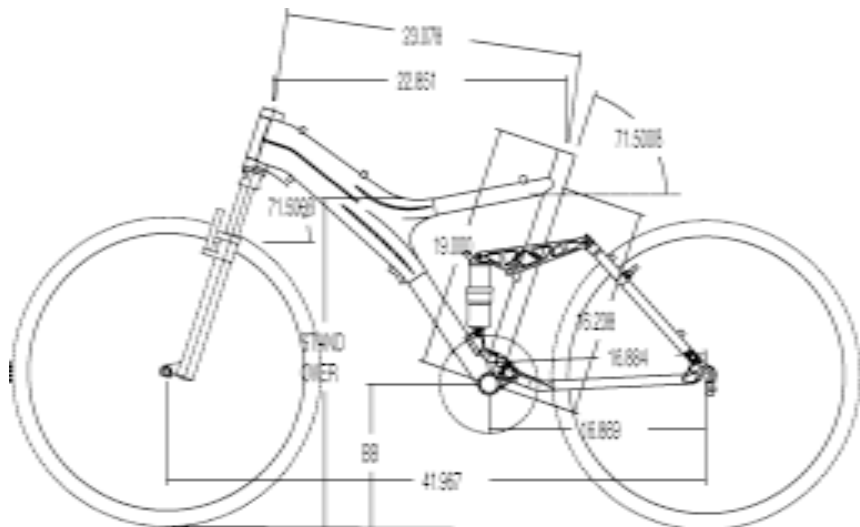
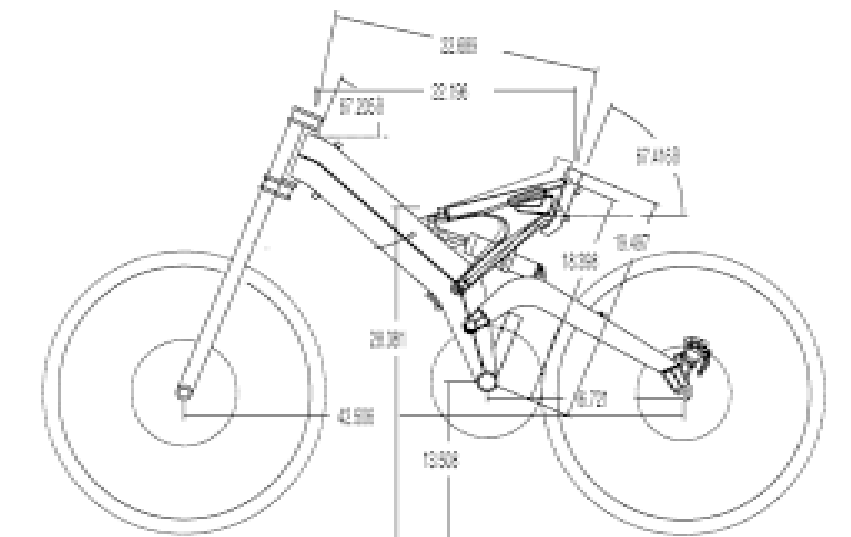

**TABLE 4 - MOHO™ CXS SPECIFICATIONS
SEE FIGURE 4**

(English)	XS	SM	MD	LG	(Metric)	XS	SM	MD	LG
TT	21.0	23.0	23.1	23.3	TT	53.2	58.3	58.6	59.1
TT'	20.5	22.0	22.9	23.2	TT'	52.0	55.8	58.2	58.9
ST	17.5	18.0	19.0	20.0	ST	44.5	45.7	48.3	50.8
ST'	15.8	16.1	16.3	17.7	ST'	40.1	41.0	41.5	44.8
Wheel Base	40.9	41.9	41.9	41.9	Wheelbase	103.9	106.4	106.4	106.4
BB	12.3	12.3	12.3	12.3	BB	31.2	31.2	31.2	31.2
CS	16.7	16.8	16.9	16.9	CS	42.5	42.8	42.8	42.8
CS,	16.9	16.9	16.8	16.8	CS'	42.8	42.8	42.8	42.8
ST°	74.4°	73.2°	73°	73°	ST	74.4	73.2	73.0	73.0
HT°	71.9°	12.3°	72.3°	72.3°	HT	71.9	72.3	72.3	72.3
Stand Over	26.6	26.6	26.6	26.6	Standover	67.6	67.6	67.6	67.6

Derailleur Post = 34.9

FIGURE 2 - SAN ANDREAS™ DHS



**TABLE 2 - SAN ANDREAS™ DHS SPECIFICATIONS
SEE FIGURE 1**

(English)	SMALL	REGULAR	(Metric)	SMALL	REGULAR
TT	21.9/20.9	23.0/22.0	TT	55.6/53.1	58.2/55.6
TT'	21.8/20.8	22.8/21.8	TT'	55.4/52.8	57.9/55.4
ST	18.8/19.2	19.5/19.9	ST	47.8/48.8	49.5/50.5
ST'	17.8/18.0	18.4/19.0	ST'	45.2/45.7	46.7/48.3
Wheelbase	42.7/43	42.7/43	Wheelbase	108.5/109.2	108.5/109.2
BB	15.2/14.5	15.2/14.5	BB	38.6/36.8	38.6/36.8
CS	16.4/16.7	16.4/16.7	CS	41.7/42.4	41.7/42.7
ST°	69.9/68.2	69.9/68.3	ST°	69.6/68.2	69.9/68.3
	74.7/73.4°	73.6/72.3°		74.7/73.4	73.6/72.3
HT°	67/68.5°	67/68.5°	HT°	67.8/68.5	67/68.5
Standover	29.8/29.1	29.8/29.1	Standover	75.7/73.9	75.7/73.9

Derailleur Mount Tube = 31.75mm

NOTE: TT, TT', ST, ST' adjusted by moving the subframe position (rear/forward).

Wheelbase, BB, CS, ST°, HT° and Standover adjusted by moving the shock mounting position (rear/forward).

The MOHO™, designed with short chain stays and low bottom bracket height is ideal for cross-country and dual slalom racing. It also offers the same high-tech features and quality craftsmanship as the San Andreas™. The MOHO™ CXS frameset is now fully suspended.

MOHO™ STS & MOHO™CXS FRAMESETS FEATURES:

- ⚡ HMI/Monocoque 6061-T6 Aluminum frame - Sturdy monocoque main frame transitions to large diameter round tubing for superior stiffness and lightweight.
- ⚡ Wishbone-Style Seatstays - Monostay connected to CNC wishbone provides a shock dampening quality. Hence the “Softail.”
- ⚡ CNC'd Wishbone Chainstays - Machined aluminum wishbone with square tubing chainstays increase BB and rear triangle stiffness.

MOHO™ CXS MAINTENANCE:

There are grease ports located at six positions on the MOHO™ CXS:

- ⚡ Top of the rocker arm pivot lug
- ⚡ The top of each drop out
- ⚡ The center-top of the seatstay wishbone
- ⚡ A' the back of each chainstay wishbone

Before leaving the Mountain Cycle™ Factory, these ports have been filled with Teflon fortified grease. To grease these areas, remove the dot, and inject grease into the sealed ports using a needle-style grease injector once this is completed, clean the area using an all-purpose cleaner, and dry.

Due to the limits suspension framesets put on component placement, some styles of front derailleur will not work with your MOHO™ CXS. Please refer to Table 4 (page 14) to determine which model you will need.

FIGURE 3 - MOHO™ STS

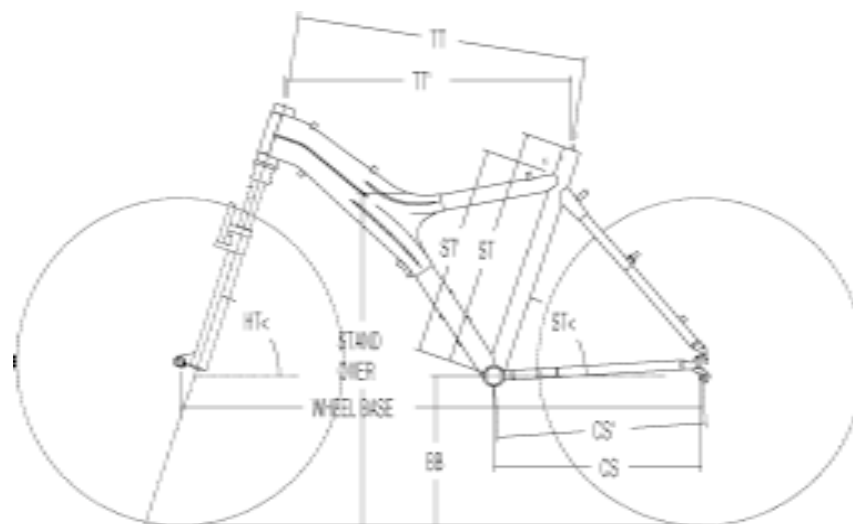

**TABLE 3 - MOHO™ SPECIFICATIONS
SEE FIGURE 3**

(English)	XS	SM	MD	LG	(Metric)	XS	SM	MD	LG
TT	21.0	22.3	23.1	23.3	TT	53.2	56.6	58.6	59.1
TT'	20.5	21.9	22.8	23.2	TT'	52.1	55.6	57.9	58.8
ST	17.5	18.0	19.0	20.0	ST	44.5	45.7	48.3	50.8
ST'	15.8	15.9	16.2	17.5	ST'	40.1	40.4	41.1	44.5
Wheel Base	40.5	41.5	41.5	41.5	Wheelbase	102.9	105.4	105.4	105.4
BB	11.9	11.9	11.9	11.9	BB	30.2	30.2	30.2	30.2
CS	16.5	16.5	16.5	16.5	CS	41.9	41.9	41.9	41.9
CS'	16.5	16.5	16.5	16.5	CS'	42.0	42.0	42.0	42.0
ST°	74.4°	73.0°	73°	73°	ST°	74°	73°	73°	73°
HT°	71.5°	71.5°	71.5°	71.5°	HT°	71.5°	71.5°	71.5°	71.5°
Stand Over	26.2	26.2	26.2	26.2	Standover	66.5	66.5	66.5	66.5
Derailleur Post = 34.9									