

Instructional  
Manual



**SUPER  
FLY**



**bomber**

MARZOCCHI SINCE 1949 MARZOCCHI SINCE 1949 MARZOCCHI SINCE 1949



**INDEX**

	Page
OWNER'S INFORMATION .....	2
GENERAL SPECIFICATIONS .....	3
GENERAL RULES FOR A CORRECT OVERHAULING AND MAINTENANCE .....	3
SPECIFIC TOOLS .....	4
FAILURES, CAUSES AND REMEDIES .....	4
RECOMMENDATIONS FOR USE .....	5
INSTALLATION .....	5
ADJUSTMENTS .....	5
DISASSEMBLY .....	6
DISASSEMBLY DIAGRAM .....	6
REASSEMBLY .....	11
FORK EXPLODED VIEW .....	15

The figures and descriptions in this pamphlet are provided as a guide.  
 We reserve the right to make changes to the products without notice in line with our policy of continuous improvement.

**Always respect Nature when riding !**

**OWNER'S INFORMATION**

**IMPORTANT:** Installing a Marzocchi suspension system is a very delicate operation that must be carried out with extreme care. These installation and maintenance instructions are designed for experienced bicycle mechanics and must be followed exactly as written and specified. Failure to precisely follow these instructions could cause damage to one or more components of the Marzocchi suspension system. This damage may not be readily visible or apparent and could lead to unexpected failure on one or more components of your suspension to such extent that the rider may loose control of the bicycle and suffer severe injury.

**The responsibility of the owner**

- 1) The Marzocchi suspension system is designed to absorb the shocks of an uneven road surface in order to give the rider more control over this bicycle. It is not designed to absorb the forces generated by jumps or other acrobatic maneuvers. If you subject the Marzocchi suspension system to repeated jumps or other acrobatic maneuvers, you could cause one or more of the components of the suspension system to unexpectedly break, resulting in a loss of bicycle control and serious injury to the rider.
- 2) Some of the parts of the bicycle, such as the brakes, steering, tires, wheel assembly and shifters may not have been adjusted at the time the Marzocchi suspension system was installed on the bicycle. Before you ride the bicycle, be sure all the parts of the bicycle were properly adjusted and functioning properly.
- 3) All of the components of the suspension system must be correctly assembled and tightened exactly to the specified torque values. Periodically check the torque of these components to insure that they are correct. Failure to properly assemble and tighten the components could cause one or more of the components to unexpectedly break, resulting in a loss of bicycle control and serious injury to the rider.
- 4) There are obvious risks associated with mountain biking and other types of bicycle riding. Despite the use of all safety equipment for the bicycle and the rider, either injuries or damages may occur. This is the responsibility of the rider. To reduce the risk of injury, all activities must be under proper supervision and only after proper training and experience. Good physical condition of the rider and the good state of the bicycle are essential to be a safe and successful rider.
- 5) Be sure to read and follow all the instructions and warnings which originally accompanied your bicycle. In addition, it is recommended for added safety and protection while riding that a good quality bicycle helmet be worn and that other safety devices such as lights, reflectors, or reflective clothing be used. Some cities and states may require the use of a helmet and other safety equipment. Follow all traffic rules and all other laws about safety equipment and use your bicycle where you are permitted to ride.
- 6) For any further information you might need, please call or write to this addresses:

**LARM**

Via Ca' dell'Orbo, 36 -  
 40055 Villanova di Castenaso (Bologna) - Italy  
 ☎ ++51/6053460 - Fax ++51/6053411

**MSC CORPORATION USA**

28231 Avenue Crocker - Unit 100  
 VALENCIA CA, 91355  
 ☎ +1 (805) 257-6630 - Fax +1 (805) 257-6636

**It is your responsibility to make sure the assembly instructions in this book are precisely followed.**

**Always ride safely and carefully.**



## GENERAL SPECIFICATIONS

- Special air/oil damped cross-country fork.
- Each leg uses pressurized air blown through a special valve before each slider as damping medium.
- Rebound damping is controlled by an adjuster reachable from the bottom of each slider.
- Oversized stanchions and full length bushings for superior rigidity.
- Parts subjected to friction are cooled and lubricated by a specially formulated oil collected on the bottom of each leg.
- Stanchions designed with a special safety feature to eliminate any chance of the stanchions becoming separated from the crown.
- Brake cable support kit available on request.
- Stanchion protection on request.

**Steer tube:** EASTON aluminum steer tubes available for 1 1/8" diameter, threadless.

**Crown:** Forged and CNC-machined BAM\* aluminum alloy.

**Arch:** Forged and CNC-machined "BAM" aluminum alloy.

**Stanchions:** EASTON aluminum with variable butting.

**Sliders:** Cast and CNC-machined "BAM" aluminum alloy.

**Air valve:** "Schraeder" type with cap. Use Marzocchi pump (item 60.02) to blow required air.

**Pilot bushing:** Full length bushing composed of a copper base and impregnated with an anti-friction coating.

**Seals:** Computer designed oil seals guarantee the highest quality seals available.

**Oil:** Specially formulated oil which eliminates foaming and viscosity break down while providing complete stiction-free performance.

**Fork leg oil:** type EBH 16 - SAE 7.5.

50 c.c each leg

**Lubrication oil:** 7 c.c. each leg

\* **BAM: Bomber Aerospace Material.**

Special alloy developed from aerospace material.

### Size:

- stroke: 65 mm (2.5 inches)
- crown to axle length: 433.2 mm
- stanchions outer diameter: 30 mm
- fork leg distance between centers: 130 mm
- cantilever boss distance between centers: 80 mm
- pilot bushing length: 92 mm

### This fork is supplied with:

- Warranty card
- Owners manual
- Technical Specifications
- Air blow adapter
- Wrench to set rebound

## GENERAL RULES FOR CORRECT OVERHAULING AND MAINTENANCE

1. Where specified, assemble and disassemble the shock absorption system only using the LARM or MARZOCCHI special tools, as shown in the table below.
2. On reassembling the suspension system, always use new seals.
3. If two screws are close one to the other, always tighten using a 1-2-1 sequence. In short, screw the first screw just up to the point it is well tightened, then tighten the second screw and then go back to the first one and screw it tighter.
4. Clean all metal parts with a special, preferably biodegradable solvent, such as trichloroethane or trichloroethylene.
5. Before reassembling, lubricate all parts in contact with each other using silicone fat spray or special oil for seals.
6. Always grease the lip seal rings before reassembling.
7. Use wrenches with metric size only. Wrenches with inch size might damage the fastening devices even when their size is similar to that of the wrenches in metric size.

## SPECIFIC TOOLS

Ref.	Item./Art.	Description and use
A	536003AB	Slider protector: to remove the oil seal from the slider
B	R 5068	Oil seal press: to press oil seal into the slider
C		Driver to fit seal pack onto the pumping rod

The diagram illustrates three tools used in the overhaul process. Tool B is a cylindrical oil seal press with a textured top surface. Tool A is a C-shaped slider protector. Tool C is a small cylindrical driver with a wider top section.

**These are the specific tools necessary for an overhaul, you may find it necessary to use common tools found in your shop.**

## FAILURES, CAUSES AND REMEDIES

This paragraph reports some failures that may occur when using the fork. It also indicates possible causes and suggests a remedy. Always refer to this table before doing any repair work.

FAILURES	CAUSES	REMEDIES
Excessive oil build up on slider	<ol style="list-style-type: none"> <li>1. Oil seal is worn out</li> <li>2. Stanchion tube is scored</li> <li>3. Excessive dirt on slider oil seal</li> </ol>	<ol style="list-style-type: none"> <li>1. Replace oil seal</li> <li>2. Replace oil seal and stanchion tube</li> <li>3. Clean the oil seal seat and replace it</li> </ol>
Oil leaking through the bottom of slider	O-ring for cartridge / slider seal damaged	Replace the O-ring
Fork has not been used for some time and is locked out	Oil seals and dust seals tend to stick to stanchion tube	Raise dust seal and lubricate stanchion tube, dust seal and oil seal with silicone grease
Pressure drop	<ol style="list-style-type: none"> <li>1. Inflating valve slow or damaged</li> <li>2. Valve seal damaged</li> </ol>	<ol style="list-style-type: none"> <li>1. Screw spreading some medium-strong glue or change the valve</li> <li>2. Change the seal</li> </ol>
The fork reaches its end of stroke easily	1. Seal pack at the bottom of the stanchion damaged	1. Change seals
Fork rebounds too fast even though the adjuster is on the max. damping position	<ol style="list-style-type: none"> <li>1. Piston ring(s) damaged</li> <li>2. Seal pack at the bottom of the stanchion damaged</li> </ol>	<ol style="list-style-type: none"> <li>1. Change piston ring(s)</li> <li>2. Change seals</li> </ol>
Excessive play of stanchions in the sliders	Pilot bushing worn out	Replace bushings
Fork rebounds too fast in any adjuster position	Legs dirty	Clean carefully and change oil
Fork is noisy during use	Pilot bushings poorly lubricated	Pour lubrication oil at the bottom of the stanchions after cleaning
Compression damping too soft, though pressure in the legs is OK	Air is leaking from the bottom into the top section of stanchion	Loosen fork leg cap just enough to let air out of the upper section of stanchion. Tighten cap and check pressure.

## RECOMMENDATIONS FOR MAINTENANCE

MARZOCCHI forks are based on advanced technology, supported by year-long experience in the field of professional mountain biking. In order to achieve best results, we recommend to check and clean the area below the oil seal and the stanchion tube after each use and lubricate with silicone oil.

**Polished** forks should be treated with bodywork polish at regular intervals to preserve their original finish.

## INSTALLATION

Installing the SUPERFLY fork on a bicycle is a very delicate operation that should be carried out with extreme care. The installation should always be checked by one of our Technical Service Centers.

**⚠ WARNING:** Steer tube/headset mounting and adjustment must be carried out in compliance with the headset manufacturer's instructions either when a threaded steer tube or an "A-Head Set" steer tube is installed. Improper installation may jeopardize the safety of the rider. The SUPERFLY fork is supplied with a proper steer tube to comply with type (A-Head Set or threaded), length and diameter of the frame on which it should be fitted. The steer tube is pressed into the crown. To replace it, contact one of our Technical Service Centers with the required tools.

**⚠ WARNING:** In case of improper installation of the steer tube into the crown, the rider might lose control of his/her bicycle, thus jeopardizing his/her safety.

Check the torque of the bolts fastening the stanchions to the crown and attaching the arch to the sliders. For recommended torque settings, see the table below:

Thread diameter	Tightening torque	
	Nm	lb ft
M4	4	2.9
M5	9	6.6
M6	11	7.5

To remove the fork legs from the crown, loosen the bolts (39, FIG. A), and remove the safety ring (1, FIG. A). For easier removal, insert a small screwdriver between the ring and its seat and then remove the complete fork legs.

**⚠ WARNING:** Be sure to install the fork legs safety rings when reassembling, so that the fork legs do not become separated from the crown even though the bolts have become loose.

## ADJUSTMENTS

**⚠ IMPORTANT:** both fork legs should be adjusted on the same position.

### FORK LEG PRESSURIZATION (FIG. B)

Blow pressurized air through the valves (16) beside the brake support boss to set COMPRESSION damping. SUPERFLY is set at the factory to a standard value of 2.5 bar. To change the pressure value, remove the protection cap (15) and depressurize each leg with the closed end. To facilitate pressurization of the fork assembled to the bicycle, use the right-angle adapter (R) supplied with the fork. Fully tighten the pump connection (P) on valve (16) or on adapter (R) and pressurize until the required value is reached. Unscrew the adapter - if fitted - and refit the cap (15). This adjustment is essential in order to have the right SUPERFLY response for the rider's weight and riding style.

FIG. A

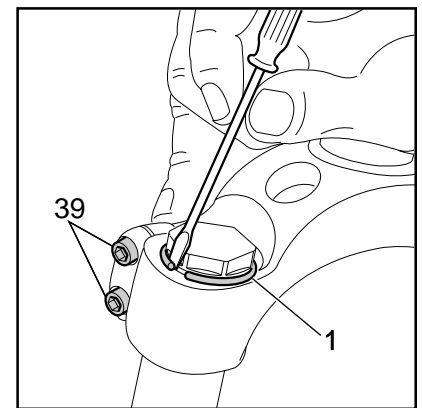
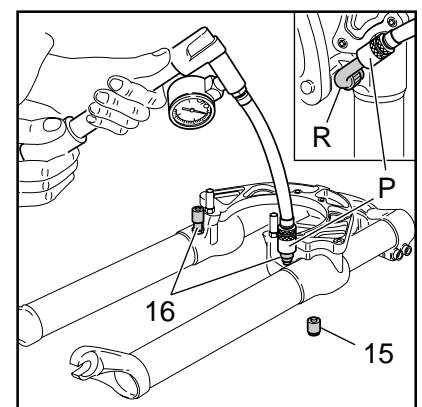


FIG. B



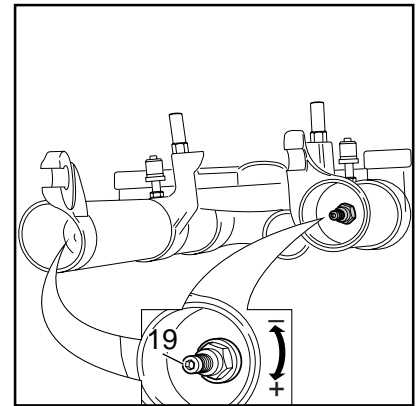


### REBOUND ADJUSTMENT (FIG. C)

Each fork leg is equipped with an adjuster screw (19) for COMPRESSION and REBOUND damping. Turn the adjuster with the 2.5 mm Allen wrench supplied with the fork. When turned, the adjuster - integral with the inner pumping rod - will change the area in which fluid flows, thus determining the rate of compression & rebound damping. To adjust, always start from the minimum damping setting, i.e. with the screw fully turned clockwise.

**⚠ IMPORTANT:** do not force the adjuster (19) over its limit.

FIG. C

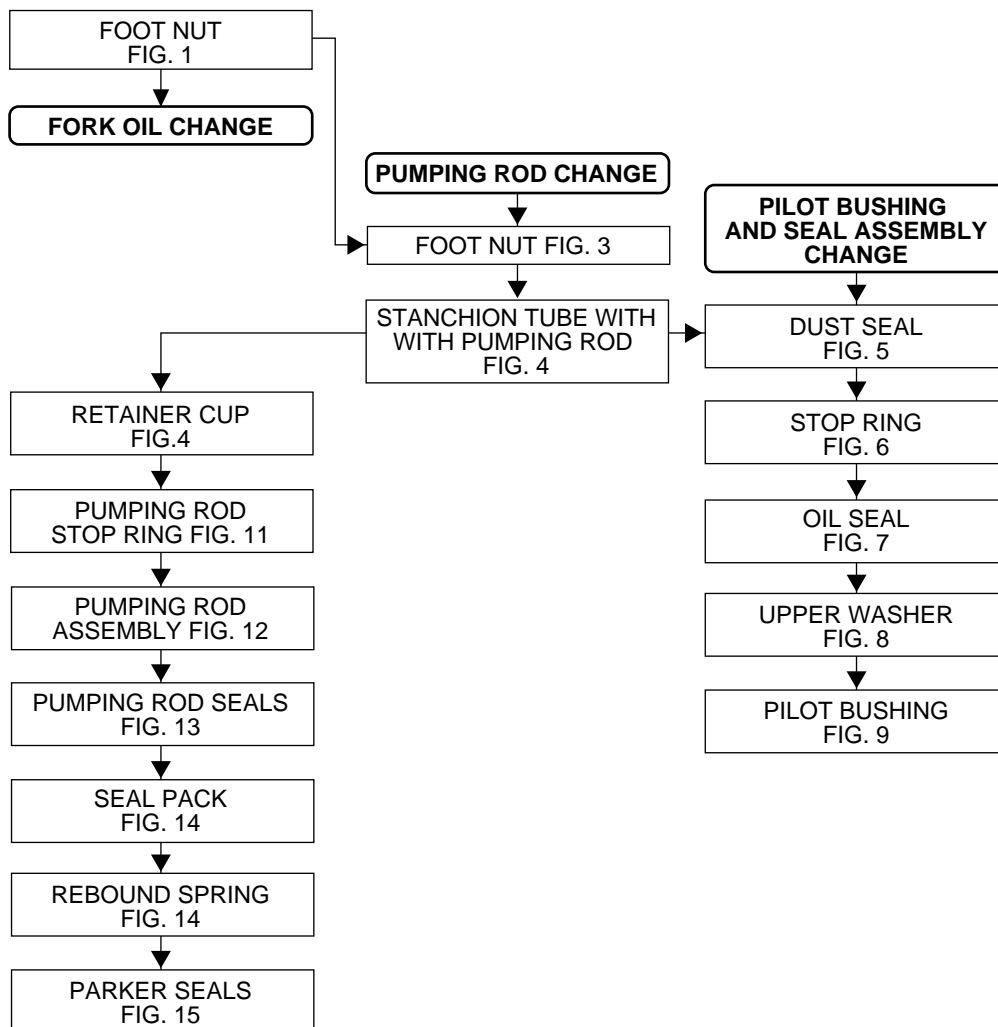


### DISASSEMBLY

#### GENERAL

- The reference numbers given in this section relate to the components shown in the fork exploded view on page 15.
- These operations refer to the fork legs having already been removed from the crown and disassembled from the brake arch.
- Before starting any operation, please read the diagram below. It shows the quickest procedure and the exact sequence in which it should be disassembled. Locate the part you need to remove in the diagram, then look at the arrows to determine which other parts you will need to remove first.

#### DISASSEMBLY DIAGRAM

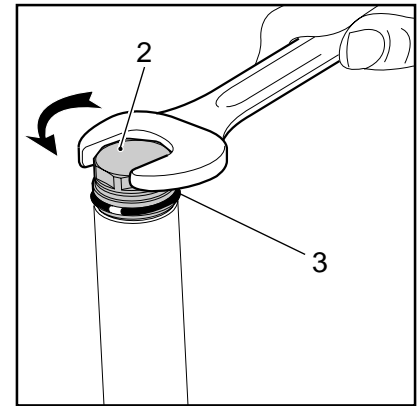


**STANCHION**

**FIG. 1**

Discharge inner pressure of each fork leg (see page 22).  
Place the stanchion tube in a vice making sure it is not damaged or dented in the process and unscrew the cap (2) with a 26 mm box wrench.  
Remove the cap complete with O-ring (3) from the stanchion tube.

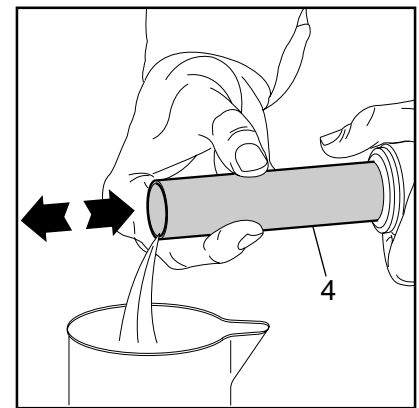
**FIG. 1**



**FIG. 2**

Push the stanchion (4) into the slider (10-11) and let all the oil drain out from the fork leg.  
Pump the stanchion several times to help oil drain off.

**FIG. 2**



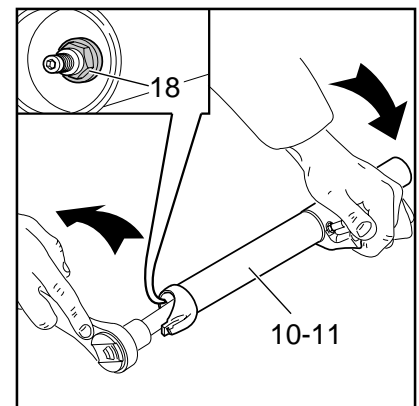
**WARNING:** Remember to always recycle any used oil.

To change the fork leg oil follow the procedure as described in section "REASSEMBLY" from FIG. 30 to FIG. 32

**FIG. 3**

**FIG. 3**

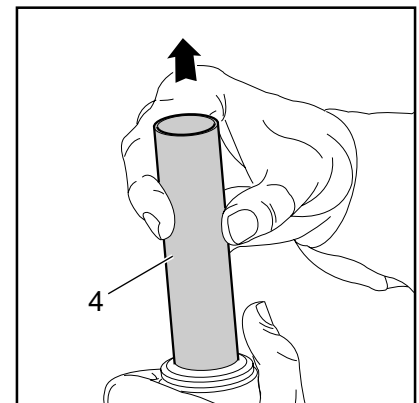
Turn the slider over and hold it steady with your hands. Unscrew the foot nut (18) with a 10 mm socket wrench. Should this operation be difficult, counteract by inserting an 8 mm Allen wrench from the stanchion top (4). Insert the wrench end into the pumping rod hex. hole (30) so that the pumping rod cannot turn.



**FIG. 4**

Pull the stanchion tube (4) complete with pumping rod (10-11) out of the slider.

**FIG. 4**

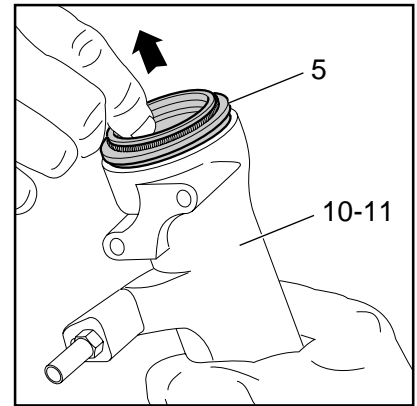


**PILOT BUSHING AND SEAL ASSEMBLY**

**FIG. 5**

Remove the dust seal (5) from the slider top (10-11).

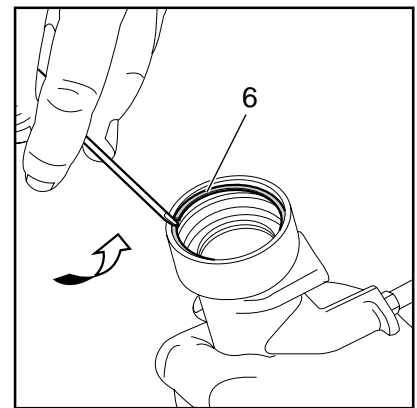
**FIG. 5**



**FIG. 6**

Remove the stop ring (6) from the slider by placing the screwdriver bit in one of the three openings on the stop ring and carefully lifting the ring out of place.

**FIG. 6**

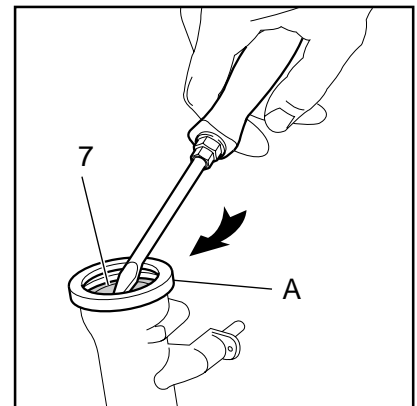


**⚠ IMPORTANT:** make sure not to damage the slider seat when removing the stop ring.

**FIG. 7**

Fit the slider protector (A) onto the slider and remove the oil seal (7) with the help of a large slot screwdriver.

**FIG. 7**

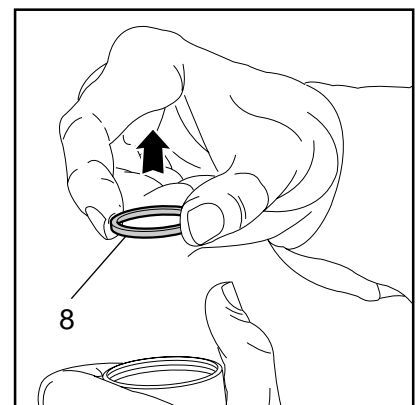


**⚠ IMPORTANT:** when removing the oil seal, make sure not to damage its seat. Once removed the oil seals should not be used again.

**FIG. 8**

Remove the upper washer (8) from the slider.

**FIG. 8**

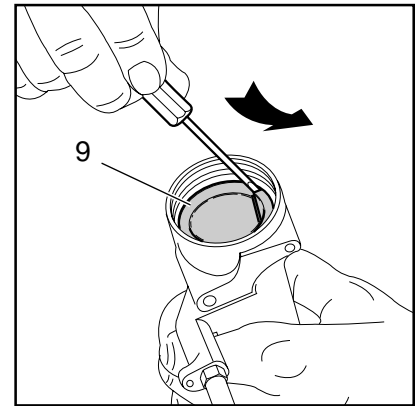




**FIG. 9**

Fit the bit of a small screwdriver into the upper edge slot of the pilot bushing (9) and lift gently. Pull the bushing out of the slider and make all necessary changes.

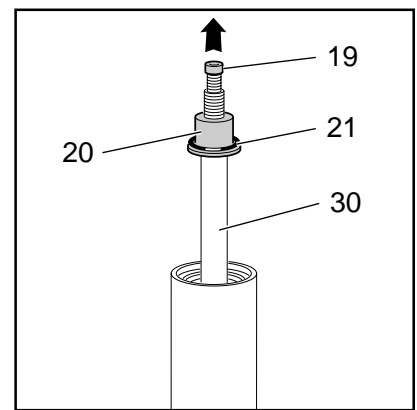
**FIG. 9**



**FIG. 10**

Pull out the retainer cup (20) complete with O-ring (21) from the pumping rod (30) top. Make sure the adjuster (19) is properly tightened on the inner rod top (34). If not, unscrew the adjuster and spread a medium-strong glue to avoid it gets loose during use.

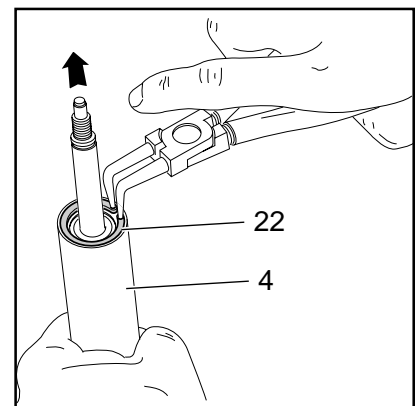
**FIG. 10**



**FIG. 11**

Remove the stop ring (22) from the stanchion tube bottom (4) with bit pincers.

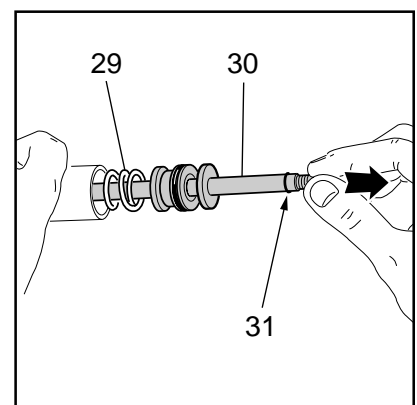
**FIG. 11**



**FIG. 12**

Push with a rubber drift –inserted from the stanchion top- and remove the pumping rod (30) with rebound spring (29). Remove the O-ring (31) at the pumping rod bottom (30).

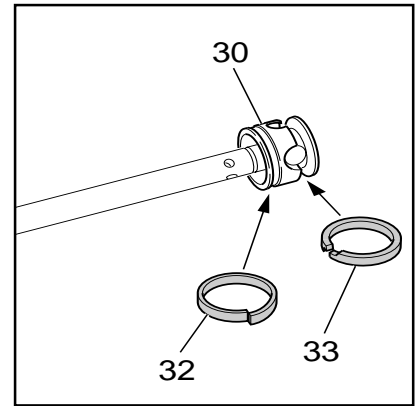
**FIG. 12**



**FIG. 13**

Two seal rings are fitted on the pumping rod. The upper ring (33) is thicker and has fitting joints, whereas the lower ring (32) is slimmer and should be in good conditions for proper fork operation.

**FIG. 13**



**PARKER SEAL DISASSEMBLY**

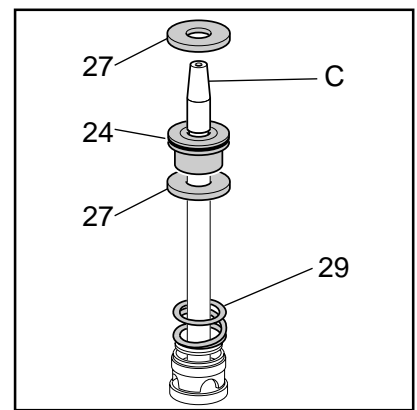


**IMPORTANT:** perform this operation only in case of fork complete overhauling or improper operation.

**FIG. 14**

Remove the lower washer (27).  
Use a proper driver (C) screwed on the pumping rod thread so not to damage seal pack (24).  
Pull out the seal pack (24) complete with seals, upper washer (27) and rebound spring (29) from the pumping rod.

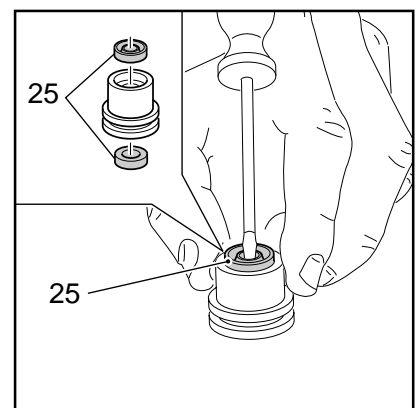
**FIG. 14**



**FIG. 15**

Remove the upper and lower Parker seals (25) from the seal pack (24) with a small screwdriver.

**FIG. 15**



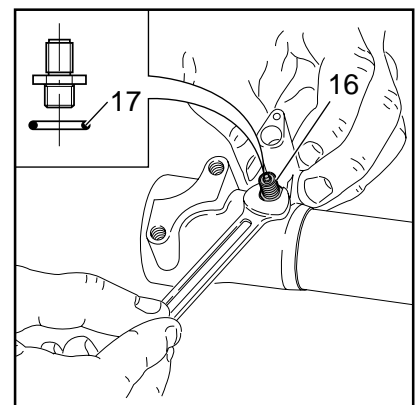
**IMPORTANT:** once removed, Parker seals should not be used again.

**AIR VALVE DISASSEMBLY**

**FIG. 16**

In case of pressure drops, remove the air valve (16) and its OR (17) using an 8 mm Allen wrench.


**FIG. 16**



**IMPORTANT:** if the air valve is disassembled with the fork leg still assembled, keep the leg vertical so as to avoid any oil leakage.

When reassembling, slightly lubricate the OR (17) and screw the air valve (16) until it stops without forcing.

**REASSEMBLY**

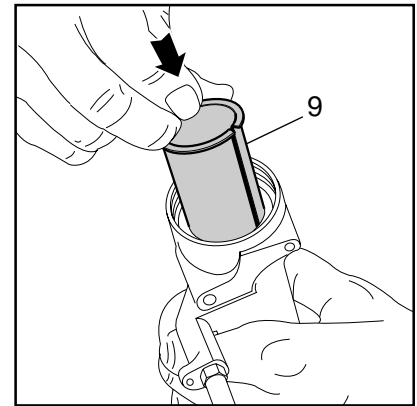
 **CAUTION:** before reassembling, all metal parts should be washed carefully with inflammable and biodegradable solvent and dried with compressed air.

**PILOT BUSHING AND SEAL ASSEMBLY**

**FIG. 17**

Check that no dirt or debris is between slider and bushing. Insert the pilot bushing (9) into place so that it adheres to the slider.

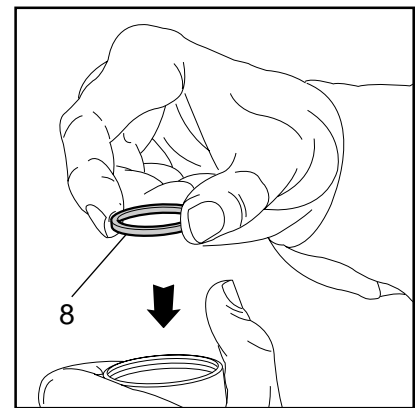
**FIG. 17**



**FIG. 18**

Fit the upper washer (8) into the slider so that it touches the pilot bushing.

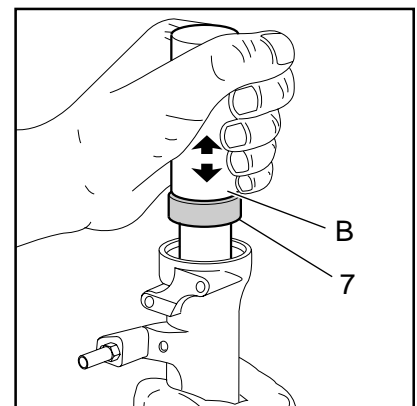
**FIG. 18**



**FIG. 19**

Lubricate the oil seal (7) and place it onto the seal press (B) with the hollow side toward the slider. Press the oil seal into place until it touches the lower washer by using the above seal press.

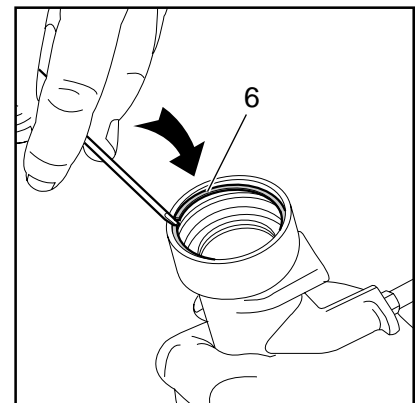
**FIG. 19**



**FIG. 20**

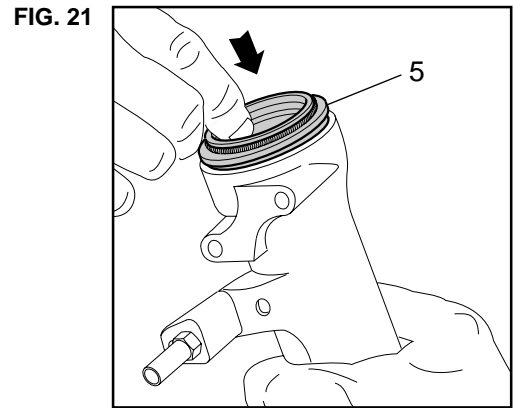
Insert the stop ring (6) making sure it is properly seated in place.

**FIG. 20**



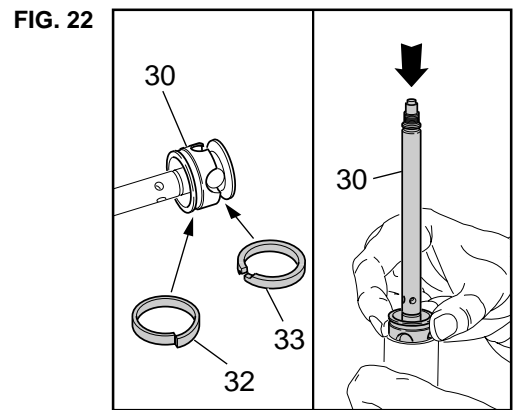


**FIG. 21**  
Lubricate the dust seal (5) and insert it into the top of the slider.



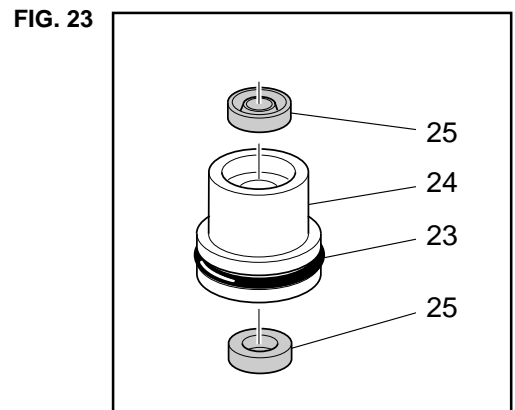
**PUMPING ROD**

**FIG. 22**  
Fit the lower (32) and upper (33) rings on the pumping rod (30). Insert the pumping rod into the bottom of the stanchion, ring side first. Push it into the stanchion, pressing the rings with your fingers.

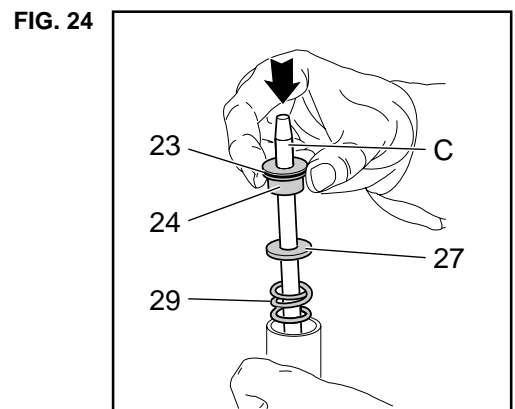


**SEAL PACK**

**FIG.23**  
Insert the lower Parker seal (25) with the hollow side downward into the pack (24) from the OR seat side. Fit the upper Parker seal (25) with the hollow side upward.  
Fit the OR (23) duly greased in the pack outer seat.



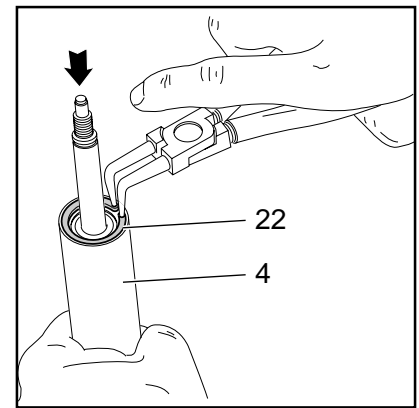
**FIG. 24**  
Screw the driver (C) on the pumping rod.  
Insert the rebound spring (29), the upper washer (27) and the seal pack (24) with the OR (23) side toward the inside.



**FIG. 25**

Push the seal pack all the way into the stanchion and fit the lower washer (27).  
Fit the outer stop ring (22).  
Make sure it is completely seated into the stanchion (4).

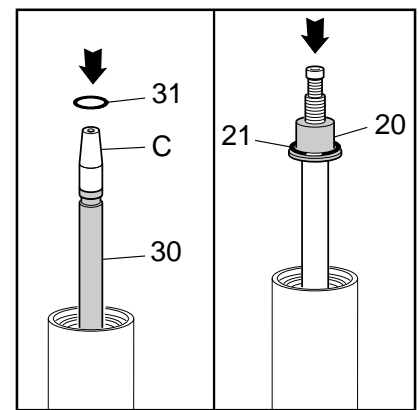
**FIG. 25**



**FIG. 26**

Fit the OR (31) duly greased in its seat in the pumping rod (30). Remove the driver (C) and fit the retainer cup (20) and the OR (21) duly greased.

**FIG. 26**

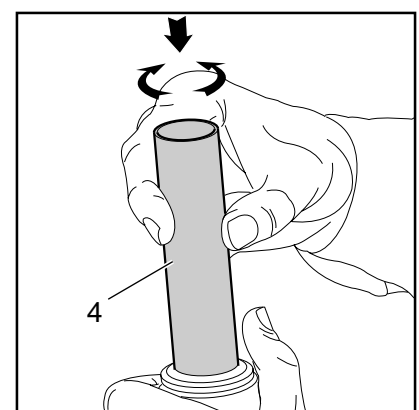


**STANCHION TUBE**

**FIG. 27**

Pull the pumping rod fully out of the stanchion.  
Insert the stanchion tube (4) gently into the dust seal. Rotate the stanchion tube while inserting it into the seal to facilitate installation and reduce the chance of damaging the seals. Push the stanchion into the slider until the rod end comes out from the slider hole.

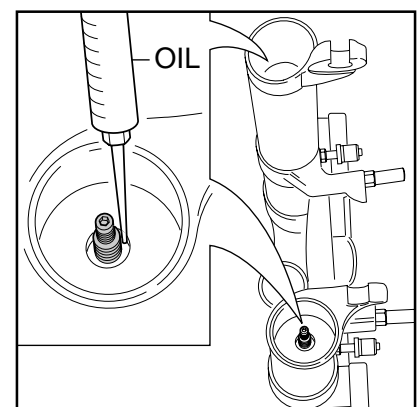
**FIG. 27**



**FIG. 28**

Turn the leg upside-down and inject 77 c.c. of lubrication oil between pumping rod end and slider with a syringe.  
Then push the pumping rod into the stanchion with a rubber drift, making sure the retainer cup (20) is visible from the slider bottom.

**FIG. 28**



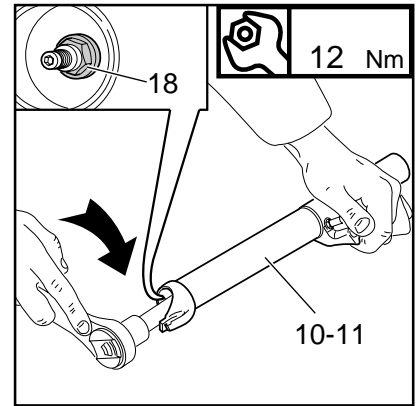
**FIG. 29**

Screw the foot nut (18) on the pumping rod treading. Hold the slider (10-11) tightly and tighten the nut at 12 Nm.

Check to see that the stanchion tube slides unrestricted by cycling the fork up and down several times.

The tube should slide freely inside the seal assembly without any play. In the event it is too hard or too soft, repeat the previous steps described above checking to ensure that components are not damaged.

**FIG. 29**

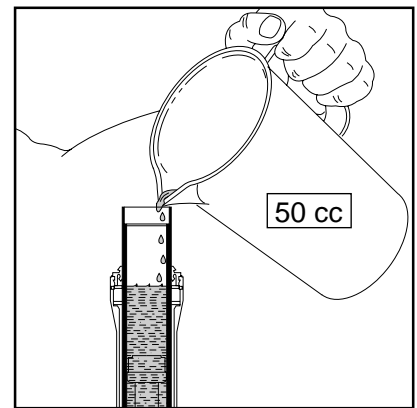


**HOW TO FILL WITH OIL**

**FIG. 30**

Unscrew the adjuster (19) to the min. position and then pour 50 c.c. of oil little by little and pump the stanchion to facilitate filling.

**FIG. 30**

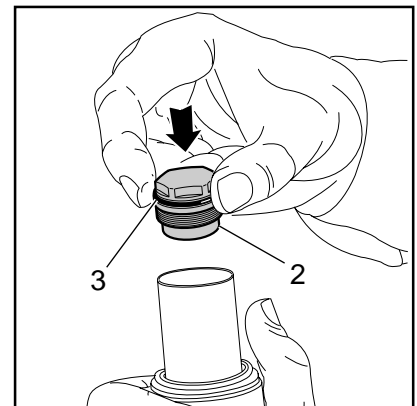


**FIG. 31**

Lubricate the OR (3) on the cap (2).

Lift the stanchion (4) and fit the cap (2) by hand.

**FIG. 31**

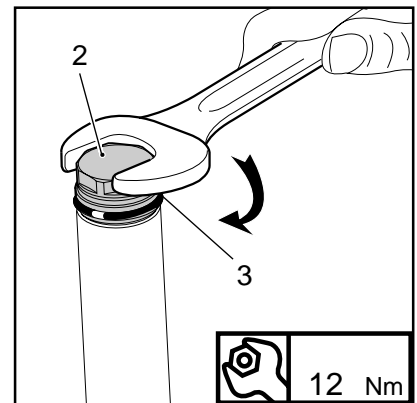


**FIG. 32**

Place the stanchion in a vice. Place the stanchion tube in a vice. Be sure it is not damaged or dented in the process and tighten the cap at 12 Nm. Pressurize as described on page 22.

At this point the brake arch can be assembled with the fork legs, which should be fitted onto the crown as specified in section "INSTALLATION".

**FIG. 32**



**FORK EXPLODED VIEW**

**Ref. Description**

- 1 Safety ring
- 2 Cap
- 3 O-ring
- 4 Stanchion
- 5 Dust seal
- 6 Stop ring
- 7 Seal ring
- 8 Upper washer
- 9 Pilot bushing
- 10 R.H. slider
- 11 L.H. slider
- 12 Arch
- 13 Screw
- 14 Cantilever boss
- 15 Valve cap
- 16 Air valve
- 17 O-ring
- 18 Foot nut
- 19 Adjuster
- 20 Retainer cup
- 21 O-ring
- 22 Safety ring
- 23 O-ring
- 24 Seal pack
- 25 Parker seal
- 26 Bushing
- 27 Washer
- 28 Safety ring
- 29 Rebound spring
- 30 Pumping rod
- 31 O-Ring
- 32 Lower seal ring
- 33 Upper seal ring
- 34 Rod
- 35 O-ring
- 36 L.H. sticker
- 37 R.H. sticker
- 38 Crown and steer tube
- 39 Screw
- 40 Sticker

