

ANSWER
MANITOU

1997
OWNER'S
MANUAL
INTERNATIONAL

Internationale Betriebsanleitung
Manual internacional
Manuel international
Manuale internazionale

Answer Products, Inc.
28209 Avenue Stanford, Valencia, CA 91355
Phone: 805-257-4411 • Sales Fax: 805-294-4179

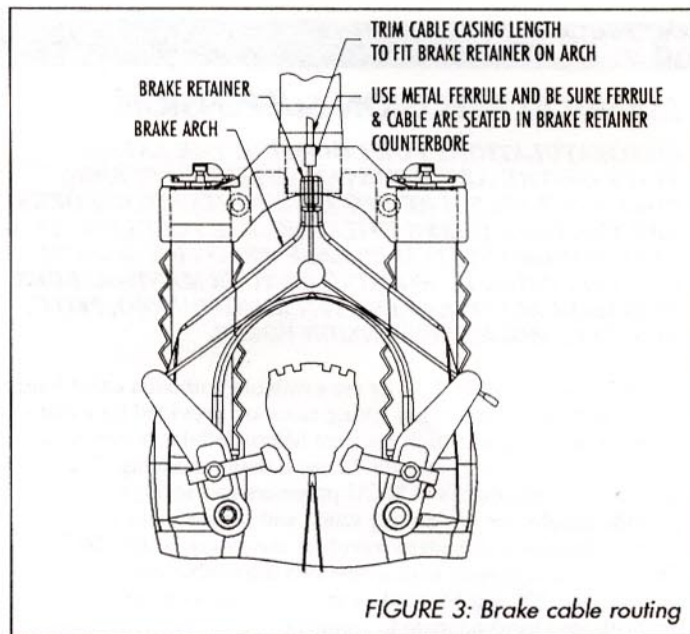
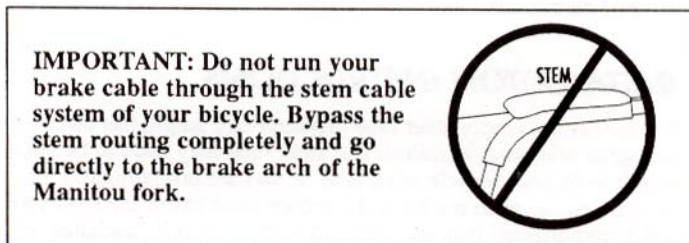
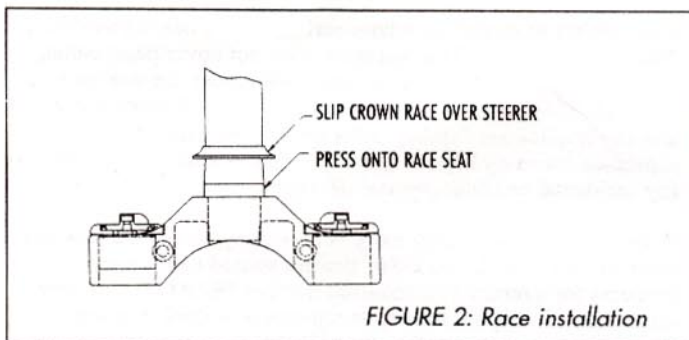

SPARE PARTS

Spare parts can be ordered through your local dealer. If you have any problems that you cannot resolve with your dealer or distributor in your country you may call Answer Products Technical / Warranty Service Department at (805) 257-4411, 8:00 AM to 5:00 PM, Pacific Standard Time, Monday through Friday.

MAINTENANCE

NOTE: The Manitou fork should not be used if any parts appear to be or are damaged. Contact your local dealer or Answer Products for replacement parts.

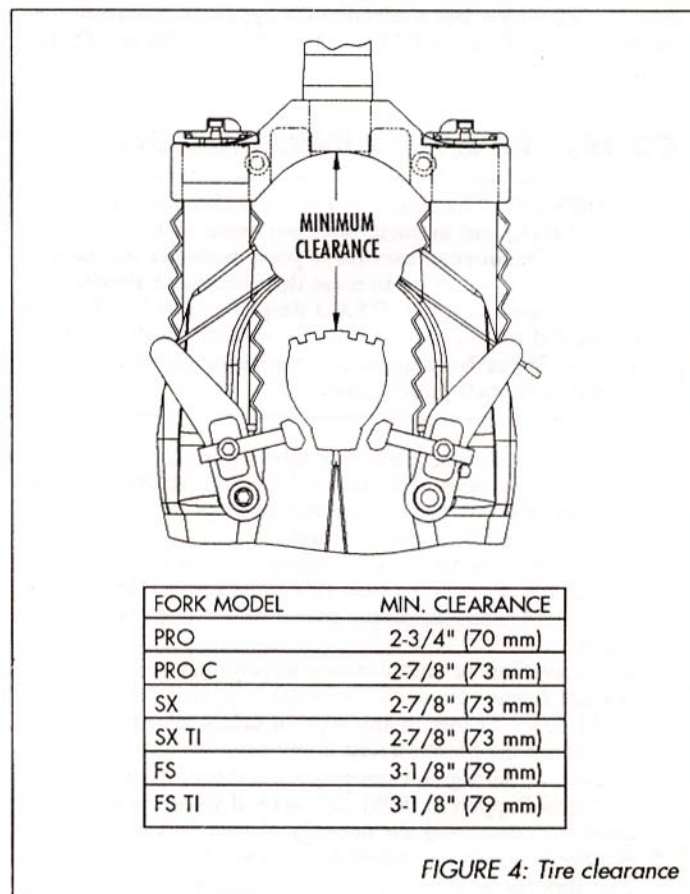

Before every ride you should:

1. Ensure that quick release skewers are properly adjusted and tight.
2. Wipe the inner legs clean and check entire fork for any obvious damage.
3. Check headset slack.
4. Insure that the front brake cable is properly seated in the cable retainer and check brake adjustment.

ADJUSTING RIDE QUALITIES

Manitou forks offer a wide adjustment range to suit individual riding preference and rider weight by simply changing the MCU elastomers or springs. Each production fork comes with a compression stack and a stock spring appropriate for an aggressive rider of 155-180 lbs. Softer, blue and harder, yellow MCU's and soft and firm spring kits for Manitou forks are available from your Manitou dealer.

Fine Tuning Pro and Pro C Models:

Fine tuning adjustments are made by removing the adjuster assembly, removing the adjuster clip and replacing it in a different groove (Figure 5). The groove closest to the top is the softest setting, while the groove closest to the bottom provides maximum preload and is the firmest setting.

Compression Stack Replacement Tuning:

Normal riding should result in 2-3/8" (60 mm) of travel. Large hits should use full travel, 2-3/4" (70 mm). Using a zip-tie as shown in Figure 6 is a good way to measure travel. To do this you must remove the fork boots, test ride, and then replace the fork boots. An excessively soft compression stack will rely too heavily on the second stage elastomer. A mushy feel with frequent noticeable bottoming will occur. An excessively firm compression stack will not use full travel. If your forks are too soft or too firm and need elastomer replacement remove the adjuster assemblies, replace the MCU's and test ride.

Fine Tuning SX and FS Models:

Fine tuning adjustments for the SX and FS are made by rotating the adjuster knobs located on top of the crown (Figure 7). Rotating the knobs clockwise will firm the ride, adding preload to the compression stack. This will firm the initial travel for small bumps but will not limit the full travel for large bumps. Rotating the knobs counter clockwise will soften the ride. Five revolutions of the adjuster knobs will take the adjuster from full soft to the extreme firm ride setting, changing the preload 1/2 inch (12.7 mm). It is not necessary to have the right and left adjusters set exactly the same.

Fine Tuning the Damping SX and FS Models:

Fine tuning damping adjustments, SX and FS models are made by rotating the damper adjuster knob located at the bottom of the left dropout (Figure 7). Rotating the knob clockwise will increase the low speed compression and the rebound damping, rotating the knob counter clockwise will reduce the amount of low speed compression and rebound damping. Full adjustment, nine clicks of the detent, will almost lockup the fork preventing it from returning after compression. It is not recommended to ride the fork with full damping. Large changes to the compression damping can be accomplished by disassembling the left damper leg and changing the shim stack and/or oil weight. The damper is built at the factory with SAE 5 weight oil. It is not recommended to exceed SAE 7 weight.

Compression Stack Replacement Tuning SX and FS Models:

Normal riding should result in 2-3/8" - 2-1/2" (60 - 63.5 mm) of travel SX and 2-5/8" - 2-3/4" (67 - 70 mm) FS. Large hits should use full travel, 2-3/4" (70 mm) SX and 3" (76 mm) FS. Using a zip-tie as shown in Figure 6 is a good way to measure travel. To do this you must remove the fork boots, test ride, and then replace the fork boots. An excessively soft compression stack will rely too

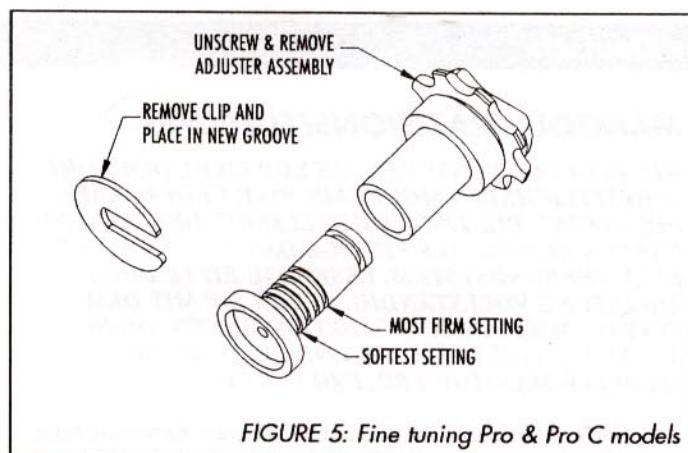

FIGURE 5: Fine tuning Pro & Pro C models

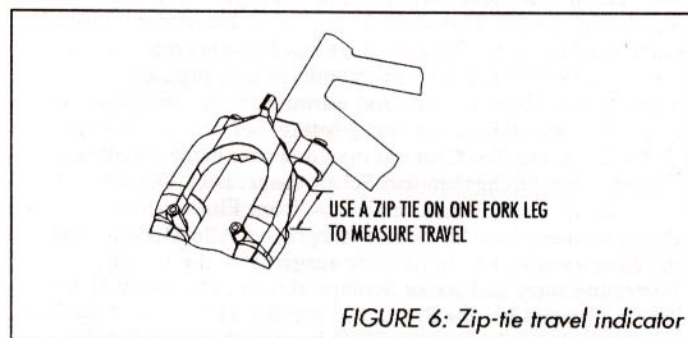

FIGURE 6: Zip-tie travel indicator

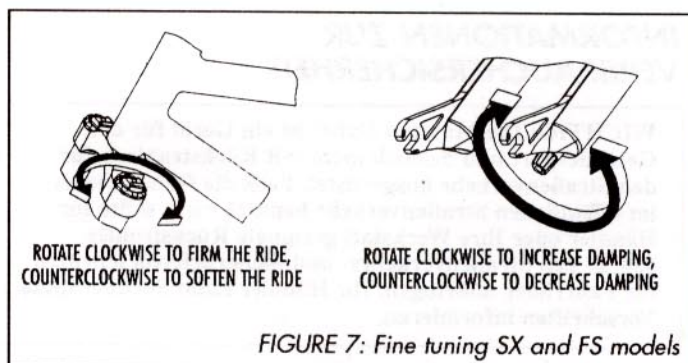

FIGURE 7: Fine tuning SX and FS models

heavily on the second stage elastomer. A mushy feel with frequent noticeable bottoming will occur. An excessively firm compression stack will not use full travel. If your forks are too soft or too firm and need elastomer replacement remove the adjuster assemblies, replace the MCU's and test ride.

Disassembly of the fork is not required. Soft and firm ride kits are available through your dealer as an accessory. The soft ride MCU kit for Manitou forks consists of six blue MCU's. The firm ride kit consists of six yellow MCU's. Any combination of MCU's can be used to obtain the ride that suits your preference, although it is not recommended to use a soft MCU like blue in a stack of hard MCU's like yellow. The soft MCU will be overpowered by the firm ones. The TI spring kits contain two blue and two red MCU's. Most tuning of titanium sprung models should be accomplished by changing out MCU's provided, but firm and soft TI spring kits are available if greater range is needed. ■

FIGURE 9: • 97 PRO C, SX & SX TI FORK SCHEMATIC

- SCHEMATISCHE DARSTELLUNG DER 97 PRO C, SX und SX TI GABELN
- ESQUEMA DE LAS HORQUILLAS 97 PRO C, SX y SX TI
- SCHÉMA DES FOURCHES 97 PRO C, SX et SX TI
- VISTA ESPLOSA DELLE FORCELLE 97 PRO C, SX e SX TI

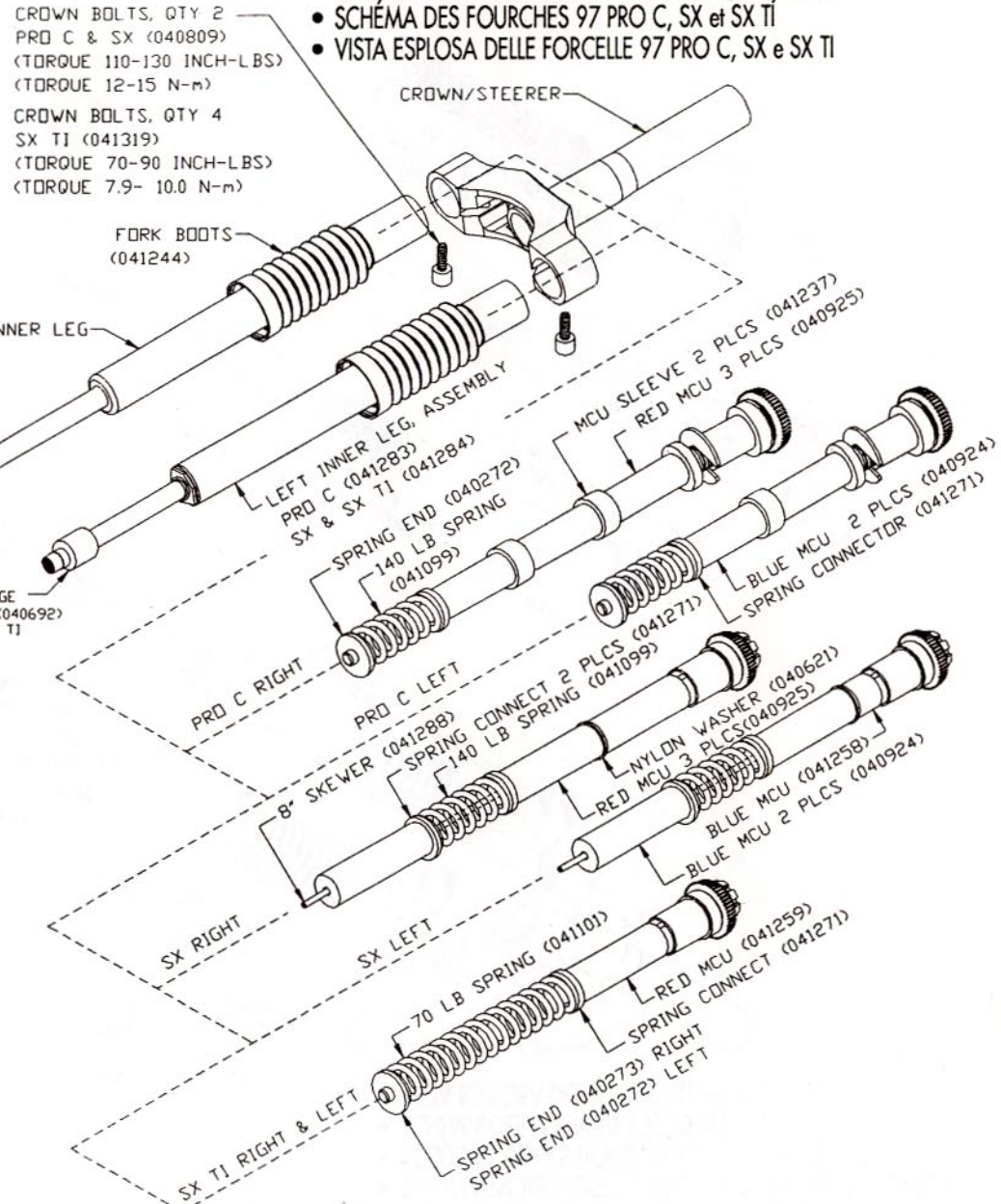
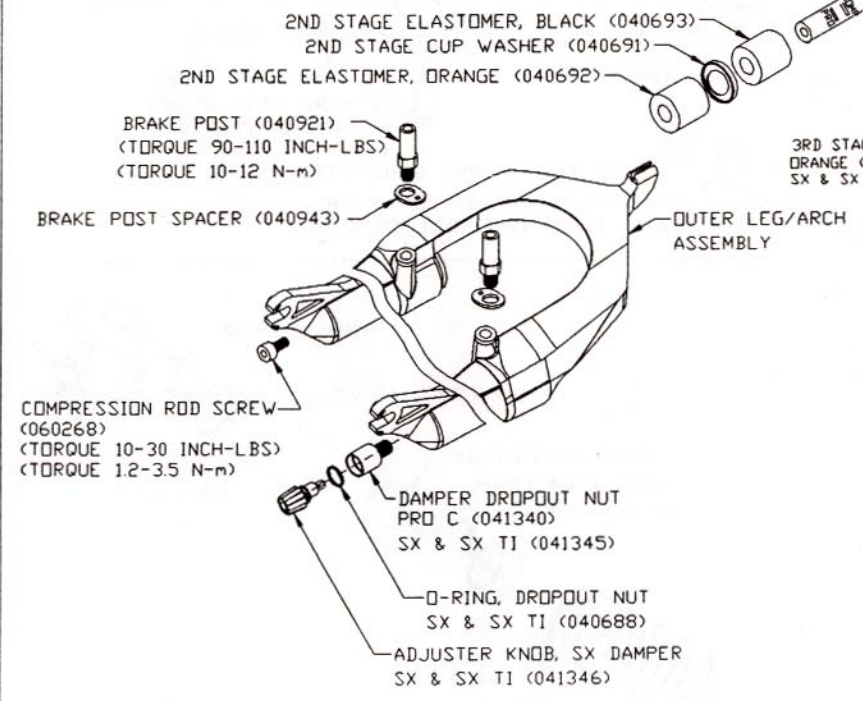
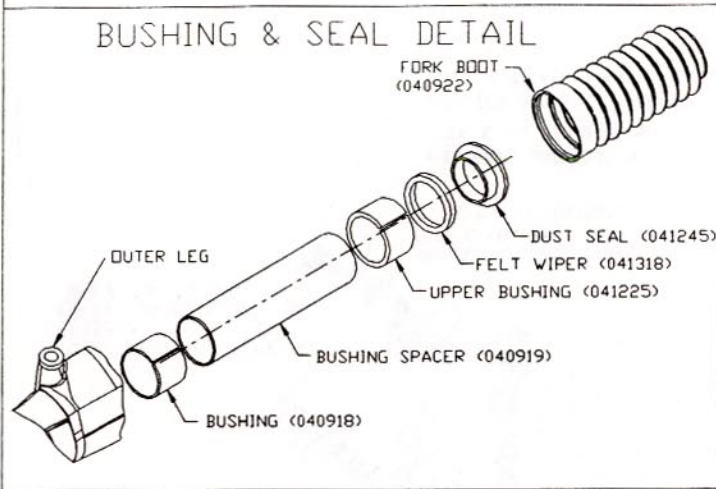

FIGURE 10: • 97 FS & FS TI FORK SCHEMATIC
 • SCHEMATISCHE DARSTELLUNG DER 97 FS und FS TI GABELN
 • ESQUEMA DE LAS HORQUILLAS 97 FS y FS TI
 • SCHEMA DES FOURCHES 97 FS et FS TI
 • VISTA ESPLOSA DELLE FORCELLE 97 FS e FS TI

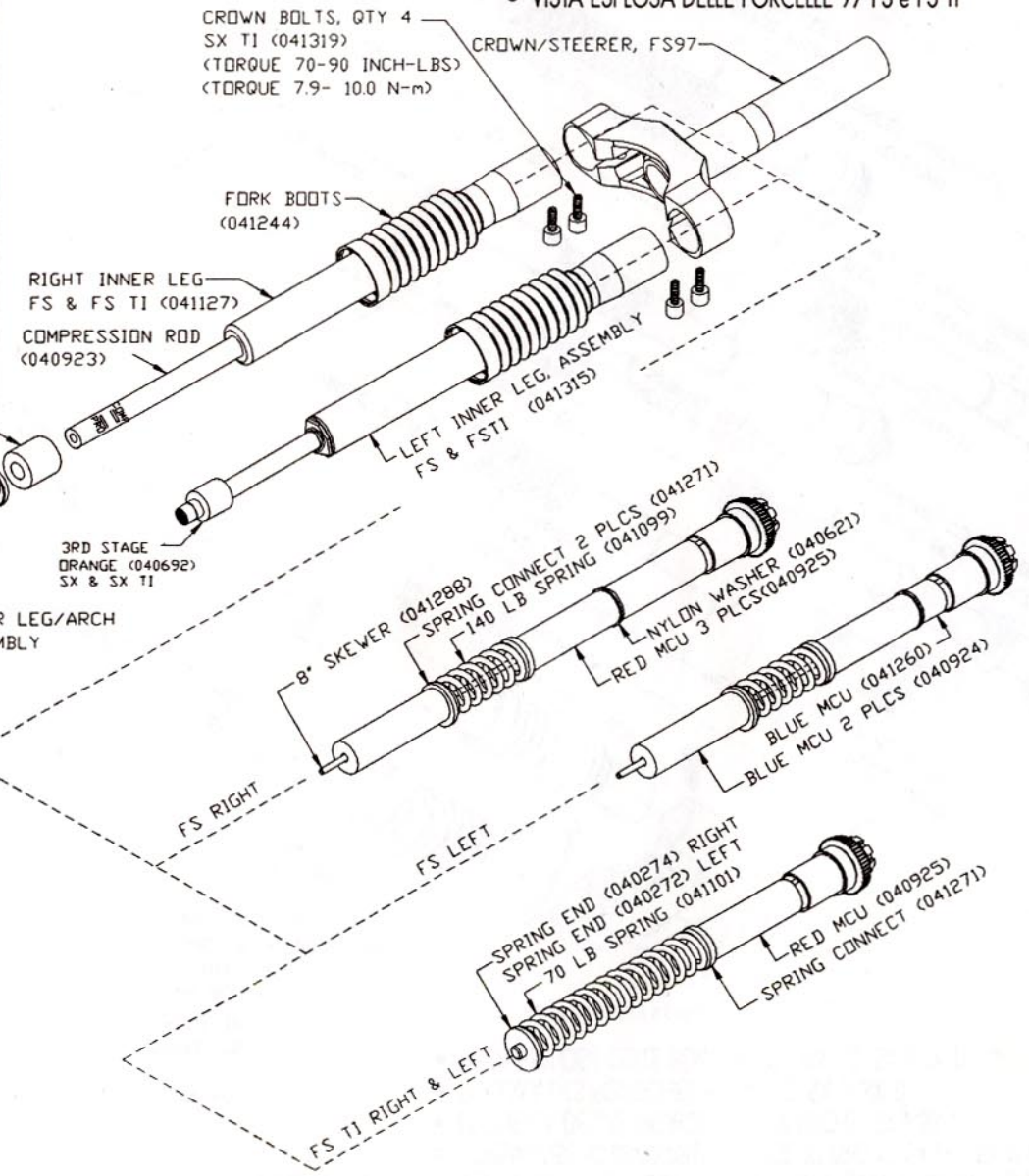
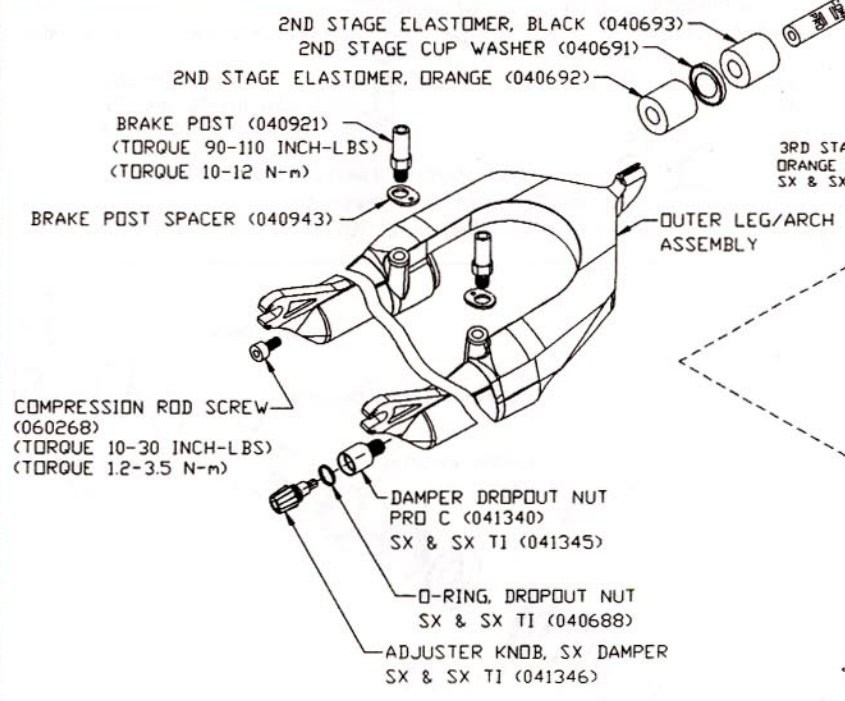
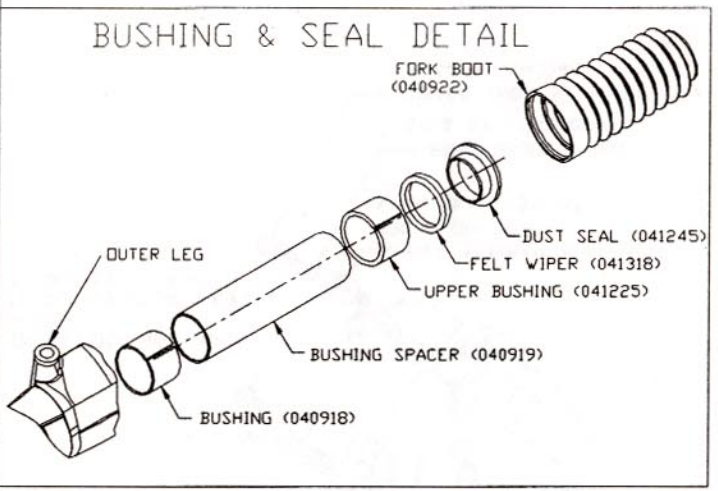

FIGURE 8:

- MACH 5 97 PRO FORK SCHEMATIC
- SCHEMATISCHE DARSTELLUNG DER MACH 5 97 PRO GABEL
- ESQUEMA DE LA HORQUILLA MACH 5 97 PRO
- SCHÉMA DE LA FOURCHE MACH 5 97 PRO
- VISTA ESPLOSA DELLA FORCELLA MACH 5 97 PRO

