



this manual covers the 1996 SRAM Corporation product line of



shifter components

SRAM™ CORPORATION
CHICAGO, ILLINOIS
U.S.A.
THE NETHERLANDS, IRELAND
TAIWAN, CHINA

GRIP SHIFT REFERENCE CHART

This chart represents SRAM's recommendations for use of GRIP SHIFT shifters with Shimano derailleurs. These recommendations include using Shimano cranks, chains, cassettes and chain rings.

Front Shifters

Shimano Front Derailleurs

	XTR	DEORE XT	DEORE LX	STX RC
<i>SRT 800-11</i>	*	*	*	
<i>SRT 800-32</i>	*	*	*	*
<i>SRT 600-11</i>	*	*	*	*
<i>SRT 600-32</i>	*	*	*	*
<i>SRT 450-11</i>				*
<i>SRT 450-32</i>				*
<i>SRT 400-11</i>				*
<i>SRT 400-32</i>				*
<i>SRT 300i-11</i>				*
<i>SRT 300i-32</i>				*
<i>SRT 200i-11</i>				
<i>SRT 200i-32</i>				
<i>MRX 100-11</i>				
<i>MRX 100-32</i>				
<i>QS 60-11</i>				
<i>QS 60-32</i>				

Rear Shifters

Shimano Rear Derailleurs

	XTR	DEORE XT	DEORE LX	STX RC
<i>SRT 800-81</i>	*	*	*	
<i>SRT 600-81</i>	*	*	*	
<i>SRT 600-71</i>				*
<i>SRT 450-71</i>				*
<i>SRT 400-71</i>				*
<i>SRT 300i-71</i>				*
<i>SRT 200i-61</i>				
<i>SRT 200i-51</i>				
<i>MRX 100-71</i>				
<i>QS 60-61</i>				
<i>QS 60-51</i>				

Front Shifters, cont'd

Shimano Front Derailleurs

	STX	ALIVIO	ACERA X	ALTUS	TOURNEY
<i>SRT 600-11</i>	*	*	*		
<i>SRT 600-32</i>	*	*	*		
<i>SRT 450-11</i>	*	*	*		
<i>SRT 450-32</i>	*	*	*		
<i>SRT 400-11</i>	*	*	*		
<i>SRT 400-32</i>	*	*	*		
<i>SRT 300i-11</i>	*	*	*	*	
<i>SRT 300i-32</i>	*	*	*	*	
<i>SRT 200i-11</i>				*	
<i>SRT 200i-32</i>				*	
<i>MRX 100-11</i>		*	*	*	*
<i>MRX 100-32</i>		*	*	*	*
<i>QS 60-11</i>				*	*
<i>QS 60-32</i>				*	*

Rear Shifters, cont'd

Shimano Rear Derailleurs

	STX	ALIVIO	ACERA X	ALTUS 7spd	ALTUS 6spd	TOURNEY 5spd
<i>SRT 600-71</i>	*	*				
<i>SRT 450-71</i>	*	*				
<i>SRT 400-71</i>	*	*	*			
<i>SRT 300i-71</i>	*	*	*			
<i>SRT 200i-61</i>					*	
<i>SRT 200i-51</i>						*
<i>MRX 100-71</i>		*	*	*		
<i>QS 60-61</i>					*	
<i>QS 60-51</i>						*

***** ESP 900 Shifters and ESP Derailleur System ¹**

Front Shifters ³

Front Derailleurs

	XTR	DEORE XT	DEORE LX
<i>ESP 900-11</i>	*	*	*
<i>ESP 900-32</i>	*	*	*

Rear Shifter ²

Rear Derailleur

	ESP
<i>ESP 900-81</i>	*

1. The ESP Derailleur System is designed to work with current Shimano 8spd MTB cassettes and chains.
2. The ESP rear shifter is compatible only with the ESP rear derailleur.
3. The ESP front shifters are compatible with Shimano XTR, XT and LX front derailleurs.



INTRODUCTION

For model year 1996 we have improved and expanded our product line with several new models and upgrades. Foremost, we are introducing the SRAM ESP Derailleur System, a complete rework in high performance/all condition MTB gear shifting. The SRT 450 integrated shifter/brake lever is also new this year, as are Dual Seals for the ESP 900 & X-RAY 800's, and wide spread spec of stainless steel springs and better shifter cables.

This manual covers the entire 1996 Grip Shift shifter line-up, plus the ESP 900 shifter and the Bassworm seal; maintenance and parts descriptions. We've also included a bird's eye view of modern index shifting design, a trouble shooting guide, and a 'glossary' to steer you through the SRAM nomenclature.

What hasn't changed is our commitment to keeping things simple and effective, not to mention serviceable. SRAM products are designed to be properly maintained, conventionally, with as little cost and inconvenience as possible. Please contact us or your local distributor for further information regarding system and spare parts availability.

WARRANTY

SRAM Corporation will warranty any Grip Shift system, unit or part for up to two years from the date of purchase, that is found by the manufacturer or its authorized agents to be defective in materials and/or workmanship.

The ESP Derailleur System and the Bassworm are warranted against defects in materials and workmanship for up to one year from the date of purchase as found by SRAM Corporation or its authorized agents.

Replacement or repair will be executed at the option of SRAM Corporation. Breakage or damage that occurs as the result of misuse and/or abuse is not covered under warranty. Alterations or modifications of any SRAM components by the user, render the warranty null and void.

Normal wear of rubber grip covers and stationary grips will not be covered under warranty. These parts are covered for manufacturing defects only.



TABLE OF CONTENTS

<i>index shifting</i>	<i>pages 3 & 4</i>
<i>shifter cleaning & lubrication</i>	<i>pages 5 & 6</i>
<i>basic trouble shooting</i>	<i>page 7</i>
<i>glossary</i>	<i>page 8</i>
<i>shifter installation</i>	<i>pages 9 & 10</i>
<i>ESP shifters</i>	<i>pages 11 - 14</i>
<i>X-RAY & SRT 600</i>	<i>pages 15 - 18</i>
<i>SRT 450</i>	<i>pages 19 - 22</i>
<i>SRT 400</i>	<i>pages 23 - 26</i>
<i>SRT 300i¹</i>	<i>pages 27 - 30</i>
<i>MRX 100 & Quick Shift</i>	<i>pages 31 - 34</i>
<i>installing grip covers</i>	<i>page 35</i>
<i>the Bassworm seal</i>	<i>page 36</i>

Notes

1. The 18 speed SRT 200i & 21 speed SRT 300i share the same assemblies, parts and maintenance.



MODERN INDEX SHIFTING

Efficiently shifting chain from sprocket to sprocket in modern indexing systems essentially relies on how effectively the drive train components can bend/change chain angle under load (front or rear shifting) to allow the destination cog(s) or chainring(s) to smoothly pick-up the chain; i.e. complete the gear shift.

Component compatibility and proper set-up is necessary for any precision shifting system:

- both front and rear indexing relies on basic principles such as correct frame alignment and derailleur positioning
- low friction/accurately tensioned cable system connections between shifter and derailleur
- correct spatial relationship of rear cog set cluster to the derailleur shifting geometry crank/chainring spatial relationship to the front derailleur shifting geometry.
- other factors that determine quality shifting include chain specification and general wear and tear of drive train components.

CABLE & HOUSING

In current indexing systems, the clicks or detents are in the shifter not the derailleur. Obviously for there to be a reliable relationship between a shifter click and a derailleur position, the cable connection between them must be precise. In this context, precise means rigid and slippery. Rigid because we want the derailleur to land in the same position relative to the cog set/chainring regardless of whether we got to that

sprocket by pulling or releasing cable (compressing housing or decompressing housing). Slippery because most of the work of shifting is actually expended overcoming friction in the cable. Therefore a flexible, smooth surface, corrosion resistant cable traveling against a low friction surface improves indexing. It happens that the frictional drag in the cable is proportional to the tension of the cable.

Further, precise index systems require properly sized, lined and capped *compressionless housing* (compressionless made rigid by small wires oriented primarily parallel with a slight helical rap), not flat coiled cable housing i.e. brake cable housing.

REAR SHIFTING/DERAILLEUR

Vital to rear indexing is an efficient (consistent & small *) *chain gap* between the top, guide pulley and the cog set. The idea is to create sufficient chain angle for the chain to move to the destination sprocket with the least derailleur movement. This is affected by the combination of:

- chain length, cleanliness
- derailleur total capacity/pulley cage size
- b-tension screw adjustment and derailleur dropout location
- derailleur dropout alignment with respect to maintaining correct geometry as the derailleur swings through its full gear range
- degree (low) of friction in the moving linkages & pulleys of the derailleur based on lubrication and wear and tear.

* Too small is a problem as the chain will not be able to get out of its own way to make the transition to the next cog; pulley chatter in the largest cogs is characteristic. Screw in the B-tension screw to open the chain gap.



MODERN INDEX SHIFTING

FRONT SHIFTING/DERAILLEUR

Vital to front shifting (index and friction) is the combination of the following factors: (primarily these properties reflect mountain bike component specifications for which we currently design our shifters) chain line, as a measurement described in this figure, should not exceed the the desired range of 47.5mm to 50mm; accurate derailleur cage positioning; staying within the given total capacity and max./min. chainring teeth tolerances of the front derailleur and drive train. Front indexing (Shimano™ Dual SIS®) relies on strict adherence to these factors in addition to a specific difference in chainring to chainring spacing from conventional, even, spaced cranks. This is linked to the system design intention: "light" & indexed front derailleur spring actuation by the shifter.

COGS, CHAIN, & CHAINRINGS

A final and major factor of quality indexing is the physical interaction between the chain and cog/chainring during shifting. The use of gated ramps on the cog /chainring face along with strong narrow chains with flared inner and outer plates makes for a more efficient chain pick up under load, by the destination cog/chainring. "Efficient" means less over shift is required of the derailleur to change gears. The transition the chain makes is smoother, especially under load. Primarily this technology applies wonderfully to shifting the chain to a larger sized cog/chainring.

**Chainline* measurement:
center of seat tube to
center of middle chainring
in millimeters. Generally 47.5mm to
50 mm is desirable.**

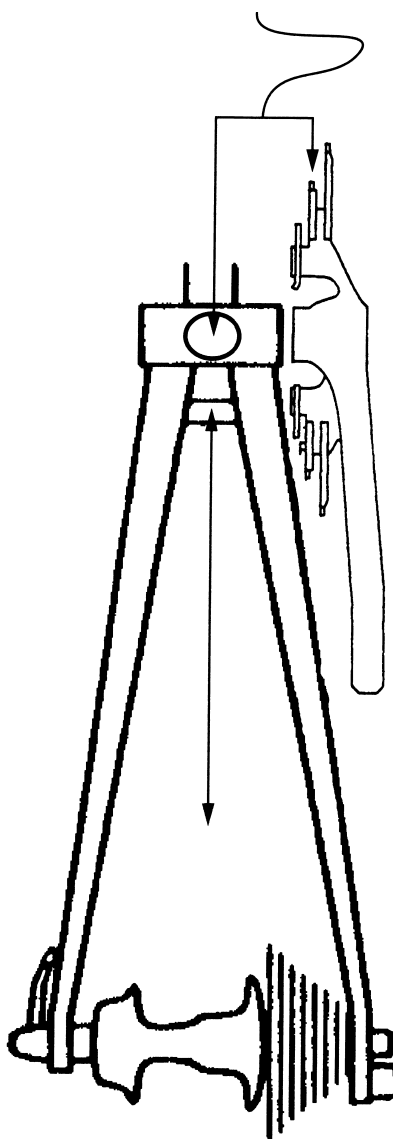

* note: use metric vernier calipers for a precision measurement



JONNISNOT

Jonnisnot is the factory installed lubricant in all Grip Shift shifters . It is specially formulated to reduce friction in the plastic to plastic and metal to plastic interfaces that exist in our shifters. It does not bloat, alter or disintegrate plastics as ordinary “bearing” greases and lube’s do and is resistant to dissipation by water. Jonnisnot and the new Finish Line™, “Grip Shift Approved” grease are the only lubricants that we currently recommend for use on our shifters. Any other possible lubricant must read “Grip Shift Approved”.

Jonnisnot is currently available in this 30cc (2 oz.) syringe from any normal Grip Shift distributor or dealer.

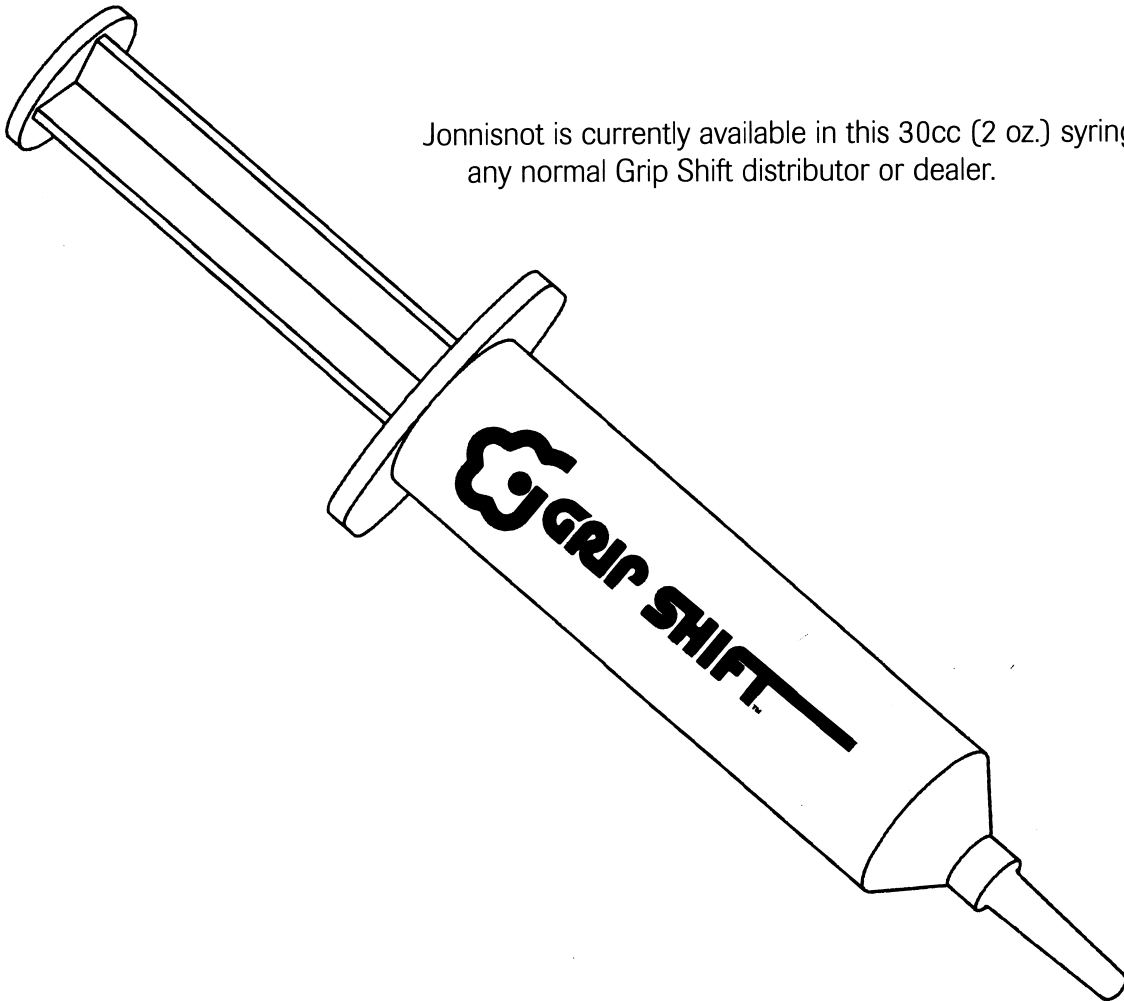

CLEANING AND LUBRICATION

We recommend that cleaning and lubrication of Grip Shift shifters should be initiated only when the shifter interior has become excessively contaminated and shifting performance deteriorates as a result: in our experience it is contamination of the cable and housing system that causes high friction build up in a shifting system and this should be examined first.

Caution: when cleaning the handle bar area of the bicycle do not use any degreasers or cleaners potential harmful to plastics and rubber compounds. Additionally, do not pressure wash or directly hose this area or any other drivetrain, brake or bearing system component as you may force contamination into these parts.

The best way to clean a Grip Shift shifter is to wipe out debris from the interior with a cotton swab. If the shifter is thoroughly contaminated it should be removed from the handlebar, dismantled and washed with a small brush in a mild dish soap and water solution. All shifter parts should then be rinsed in clean water, let air dry and relubricated as shown below. Use only Grip Shift Jonnisnot brand grease (plastics specific), or other "Grip Shift Approved" lubricants: other, normal, bike shop lubricants due to their chemical make-up can soften/bloat plastics and therefore increase friction in moving plastic parts and will damage some plastics.

1 Wipe shifter interior clean with a cotton swab or a clean cloth (if necessary, wash shifter components in a dish soap and water solution, rinse and dry).

2 Lightly re-apply "jonnisnot" to shifter as in diagram. Also add Jonnisnot to the binder bolt or set screw.

3 Re-assemble shifter and check performance.

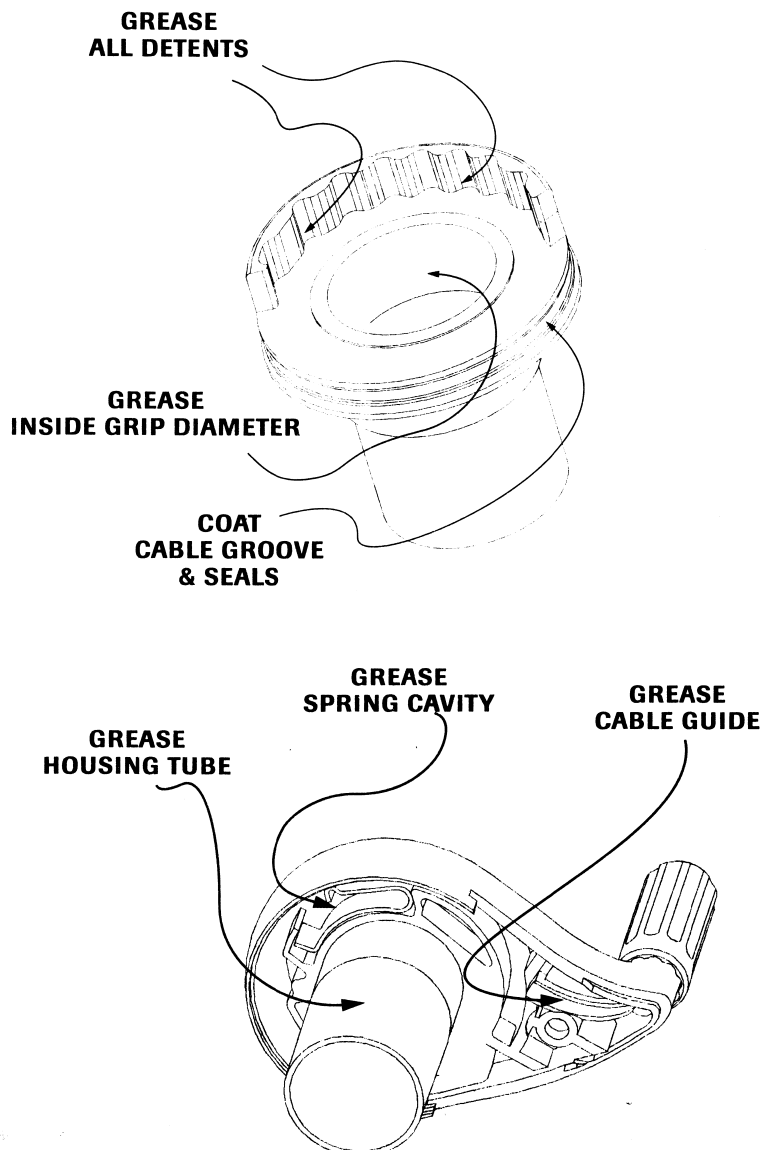



TROUBLE SHOOTING

TROUBLE SHOOTING

The following is a list of things to keep in mind if shifting goes sour.

- **High torque required to twist shifter:**

high friction in cable and housing (dirty, poor quality housing, cut too short, poor frame routing and/or braze-on placement)

shifter contaminated with dirt or wrong grease

no washer(s) between the shifter and stationary grip; stationary grip fit too tight to shifter.

handlebar diameter too small for our clamp (.875 inch +/- .01) is forcing clamp to deform shifter housing

cable clamped to wrong side of derailleur binder bolt

shifter spring facing the wrong direction or deformed: *see illustration below.*

- **Inaccurate rear indexing:**

inconsistent spec in components (inferior chain, pulleys)

high friction in cable and housing restricting rear derailleur spring back during up shifts (dirty and/or over greased, poor quality housing, sealed housing ferrules, housing lengths cut too short, kinked cable, poor frame routing and/or braze-on placement)

poor derailleur positioning and drop-out hanger alignment; cog set spaced too far or too close for derailleur actuation geometry ("d" dimension: outboard face of small cog to outboard face of hanger drop-out = .48 inches)

inconsistent spacing in the cog set (8 speed should run .48 cm (.190 inches) cog center to cog center, 7 speed = .50 cm (.197 inch)

worn or sticky pivot points in derailleur.

- **Inaccurate front shifting:**

chain line measurement, i.e. chain wheel placement exceeds front derailleur/shifter capacity (page 6)

inconsistent spec in components * (chainring sizes could be inconsistent with c-ring to c-ring tooth difference or front derailleur total capacity, compact vs. non compact drive, chains, inferior or worn chainring)

poor derailleur positioning, limiter settings

cable bound to incorrect side of derailleur binder bolt.

* when matching our FFS (short rotation front) shifters with older model front derailleurs, the level of torque required to shift may seem excessive due to the higher spring force of these earlier units.

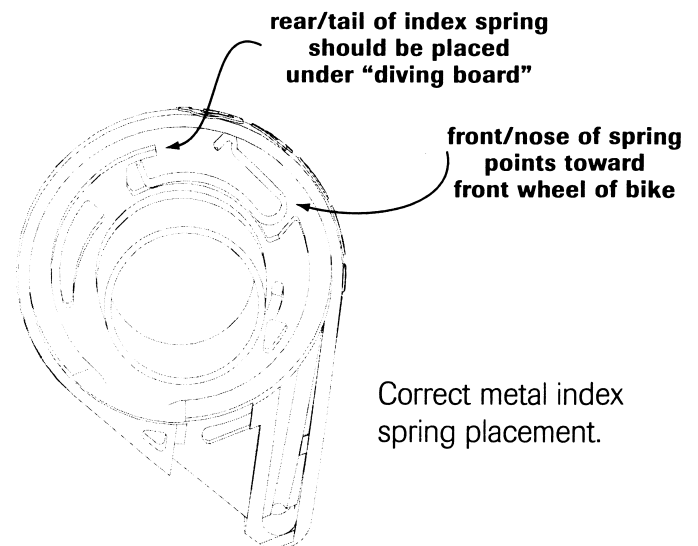



SRAM GLOSSARY

Bassworm seal: a simple stationary seal (seal moves with rear shifter cable during actuation) designed to prevent contamination of rear section of rear derailleur cable housing, adding pre-load via the elastic body of the seal can help boost cable tension/derailleur response to shifter commands.

compressionless housing: recommended index shifting specific cable housing. Stiff structure is characterized by small wires wound in a helical fashion to bend uniformly. Available in lined 3.6mm, 4mm, & 5mm outer diameter sizing (SRAM SS cables will work with all three). Slippery interior liner does not require additional lubrication.

die-drawn cable: 1.2mm zinc coated steel index shifting cable with ultra smooth exterior surface. Designed for use with 5mm cable housing. Found on the 1996 SRT 450, SRT 400, SRT 300i, and MRX-100 shifter systems.

Dual Seal: inboard and outboard seal technology located on the grip portion of the shifter assembly on the following models: ESP 900 & SRT 800 X-RAY

ESP: ...what else...?

FFS: Fastest Front Shifting. We developed this redesign in model year 1995 for our performance front shifters; effectively reducing twist rotation required for a 3 chainring shift from 140° to 70°. Found on the 1996 ESP 900, SRT 800 X-RAY, SRT 600, SRT 450 & SRT 400 shifter systems. Available in friction front and index front styles.

friction grip: multiple detent position front shifter, twist grip, designed for fine tune “trim” adjustment of the front derailleur cage.

grip: major portion of shifter assembly that the rider twists in order to shift gears. Made of hard plastic the grip is covered by a “rubber” grip cover: contains the indexing detents and seals.

grip cover: replaceable textured “rubber” sleeve mounted on the grip.

housing: other major portion of shifter assembly that the grip slides into. contains replaceable press fit handlebar clamp & bolt, cable barrel adjuster, index spring and cable guide noodle.

index grip: Dual SIS® compatible three detent position front shifter grip, available for all ESP and Grip Shift SRT systems.

noodle: replaceable low friction cable guide found in the left and right housing assemblies of the following systems: ESP 900, SRT 800 X-RAY & SRT 600.

spring: i.e. index spring, constructed in stainless steel or plastic located in the housing interior cavity.

SRAM: it’s a secret.

SRAM SS cables: ultra flexible stainless steel 1.1mm diameter index shifter cable that also has a low friction exterior profile. found in the ESP 900, SRT 800 X-RAY & SRT 600 shifter systems, and is available as an after market replacement cable. this cable will work with 5mm, 4mm & 3.6 mm compression less cable housing.

SRT: size, rotation & transition; the design goals we had for re-inventing our original straight handlebar, Grip Shift twist shifters.

ESP & SRT INSTALLATION

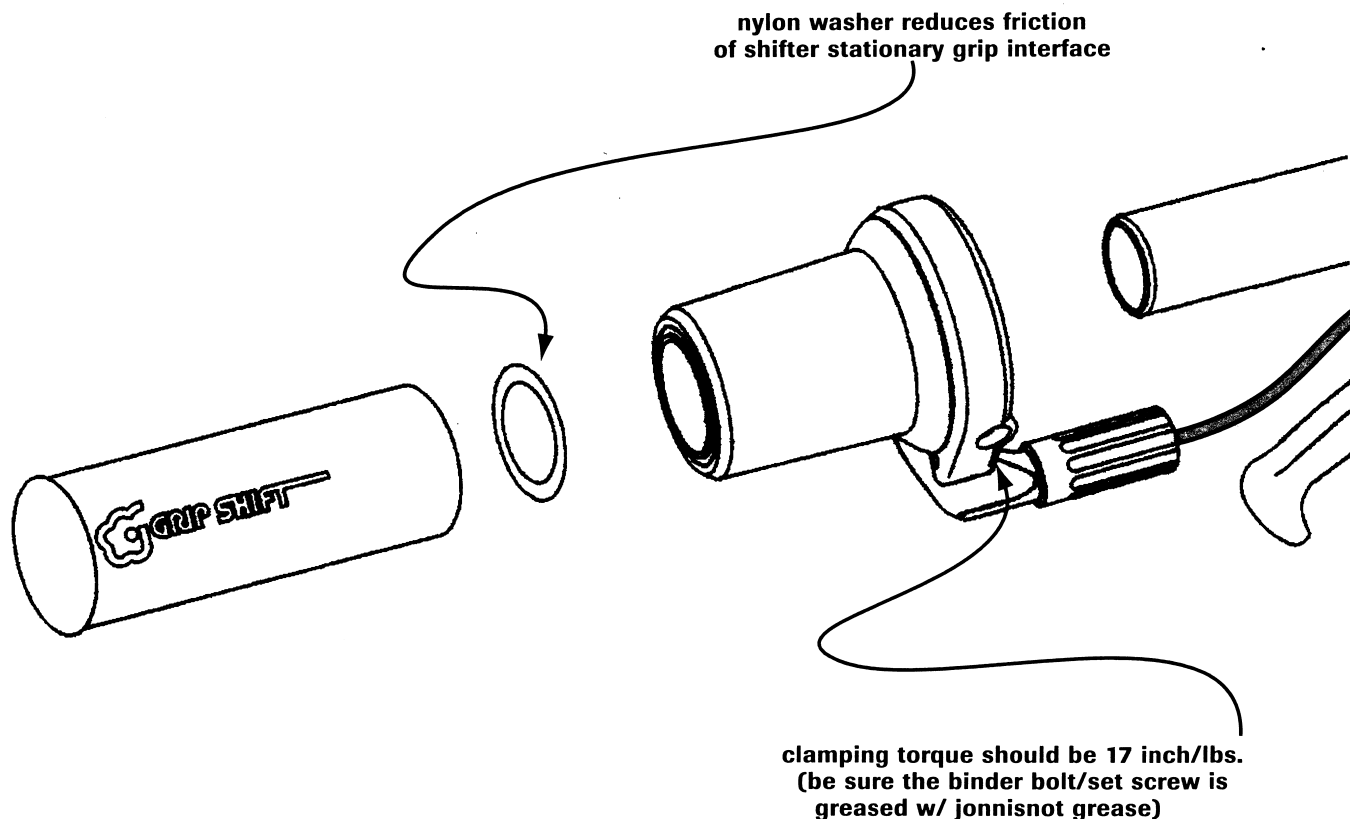

❶ Slide the shifter onto the end of the handle bar leaving adequate room for the stationary grip (and handlebar extensions). If necessary, move the brake lever to accommodate correct positioning*.

❷ Position shifter so that the derailleur cable exists beneath the brake lever (note: leave enough room for proper brake lever actuation). Fasten correctly positioned shifter and brake lever to handlebar (tightening torque for properly lubed 3mm hex bolt or 2.5mm set screw is 17 in/lbs or 20 kfg/cm)*.

**For SRT 450, correctly position shifter/brake lever assemblies into place on handlebar, leaving enough room for stationary grips (and handlebar extensions) and fasten to above torque rating. Then secure the front and rear brake cable end buttons into their respective brake levers. Thread the brake cables through their housings and braze-ons. Fasten and adjust the cables to their respective brakes per the brake manufacturer instructions.*

❸ Thread the derailleur cable through its cable housing (use new & properly measured compression less cable housing, with end-caps) and frame stops, and fasten to

ESP & SRT INSTALLATION

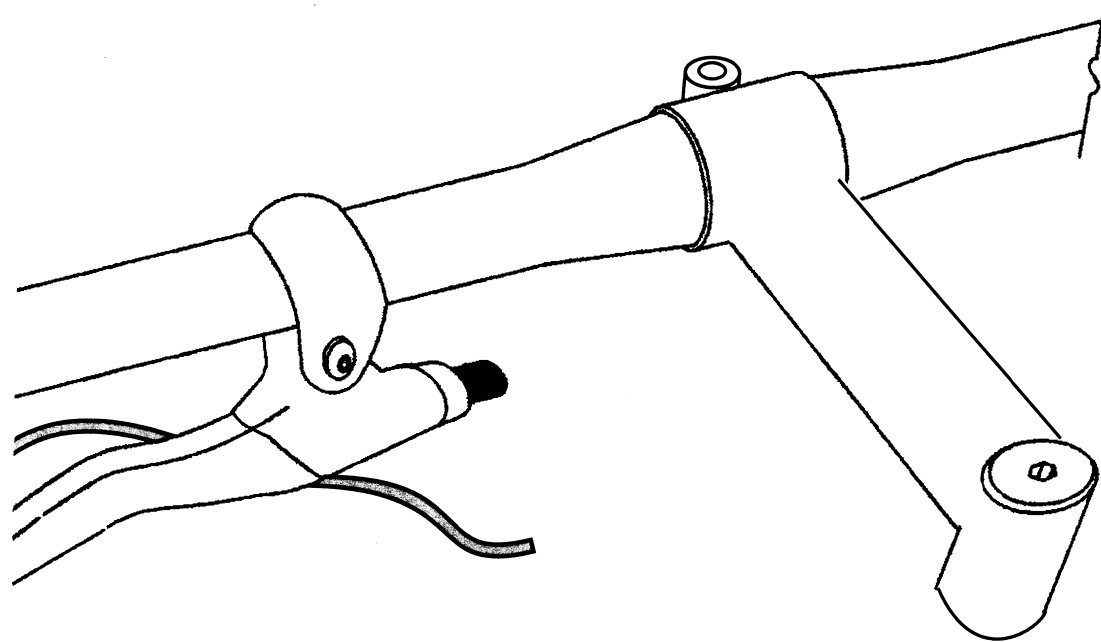

the derailleur. Adjust for proper indexing.

④ Slide the plastic 7/8" washer and then the stationary grip onto the handlebar. Do not use solvents, lubricants or hair spray to install grips: they will damage the grip rubber & possibly the shifter.

⑤ Actuate the brake levers and shifters to be certain of proper placement & installation before test riding.



ESP 900

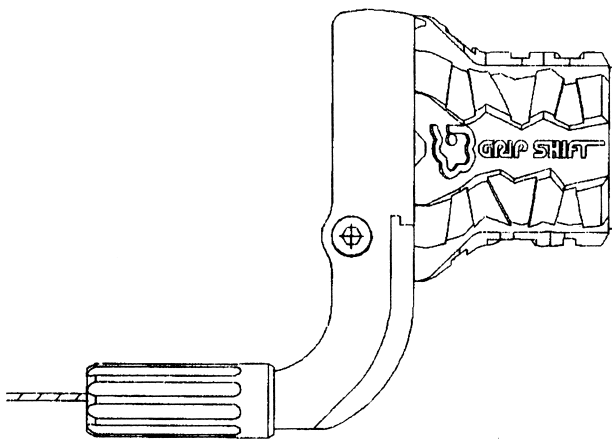

FEATURES

REAR SHIFTER SPEEDS	8 spd (ESP DERAILLEUR)
FRONT SHIFTER OPTIONS	FFS FRICTION FRONT & INDEX FRONT ¹
SEALING	DUAL SEALS
CABLE	SRAM SS 1.1mm
CLAMP STYLE	ALUM. "C", .875 INCH I.D.
BARREL ADJUSTER	INDEXING
GRIP COVER STYLE	GRANITE GRIP ²
SERVICE TOOLS REQUIRED	2.5mm & 3mm HEX KEYS, PHILLIPS HEAD SCREWDRIVER, JONNISNOT GREASE

Notes

1. Index front is Shimano Dual SIS compatible
2. ESP and X-RAY shifters can share the same rubber grip covers



PARTS, ESP 900 SHIFTERS

Part#	Description
ESP 900-11/81 ⁴	ESP Shifter System ¹
ESP 900-81	rear shifter 8 spd.
ESP 900-11	front friction shifter
ESP 900-32	index front shifter ²

REPLACEMENT PARTS

600-503	cover screw
600-502	clamping bolt
600-601	clamping collar/front
600-501	clamping collar/rear
500-609	noodle/front
500-908	noodle/rear
500-912	indexing barrel adjuster
500-807	cable cover/front
500-906	cable cover/rear
500-808	outboard seal
500-508	inboard rubber seal
600-401	index spring
200-215	housing assembly, rear ⁵
200-216	housing assembly, front ⁵
200-251	rear grip, ESP 8spd ⁶
200-249	front grip, friction ⁶
200-250	front grip, index ^{2&6}
600-901	cable set screw
700-802	replacement cable, SRAM SS 1.1mm
500-910	Granite rubber grip cover ³

Notes

1. Rear shifting is compatible only with the ESP rear derailleur.
2. Will work with DUAL SIS compatible componentry only
3. The ESP 900 & X-RAY 800 share the same grip cover options.
4. This is the *aftermarket kit system*: packaged shifter set including cables, GSR stationary grips, grease, washers, and assembly instructions.
5. This assembly includes housing body, guide noodle, clamp & bolt, and barrel adjuster.
6. This assembly includes grip, rubber grip cover and both inboard and out board seals

ESP REAR SHIFTER

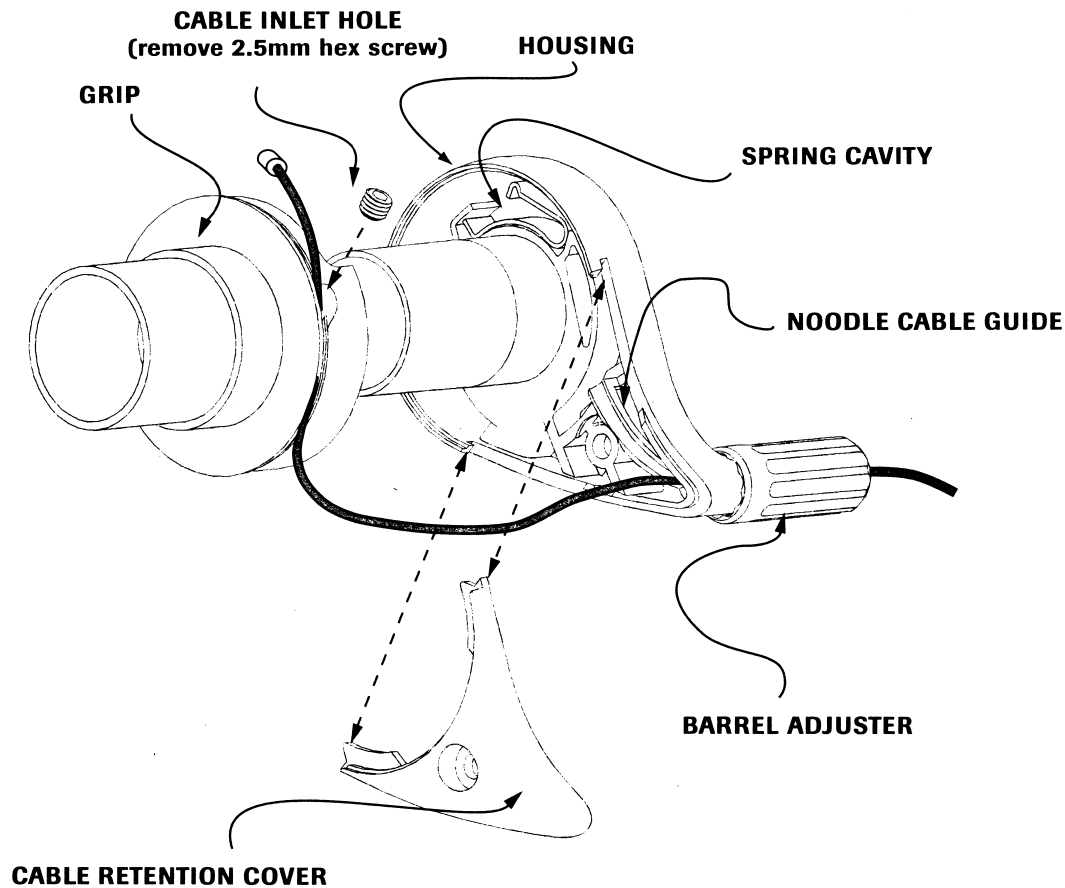

REAR SHIFTER CABLE REPLACEMENT

(note : for best results do not remove the shifters from the handlebar. Use only new and high quality cable, and compressionless housing!)

- ❶ Rotate shifter grip so that chain positions onto smallest cog or chainring. Detach the cable from derailleur.
- ❷ Slide the stationary handlebar grip away from the shifter.
- ❸ Remove the triangular shaped, cable retention cover plate with Phillips head screwdriver. Open the shifter by

sliding the GRIP away from the shifter HOUSING body. Note: the metal index spring may dislodge from its cavity in the process. REAR SHIFTER: Remove the cable button retention screw from the cable inlet hole, using a 2.5mm hex wrench.

- ❹ Remove & discard the old cable. Be sure to wipe the cable clean of debris before pulling it through the shifter (if shifter is contaminated, clean and relubricate properly before reassembling: see "Clean & Lube").

ESP FRONT SHIFTER

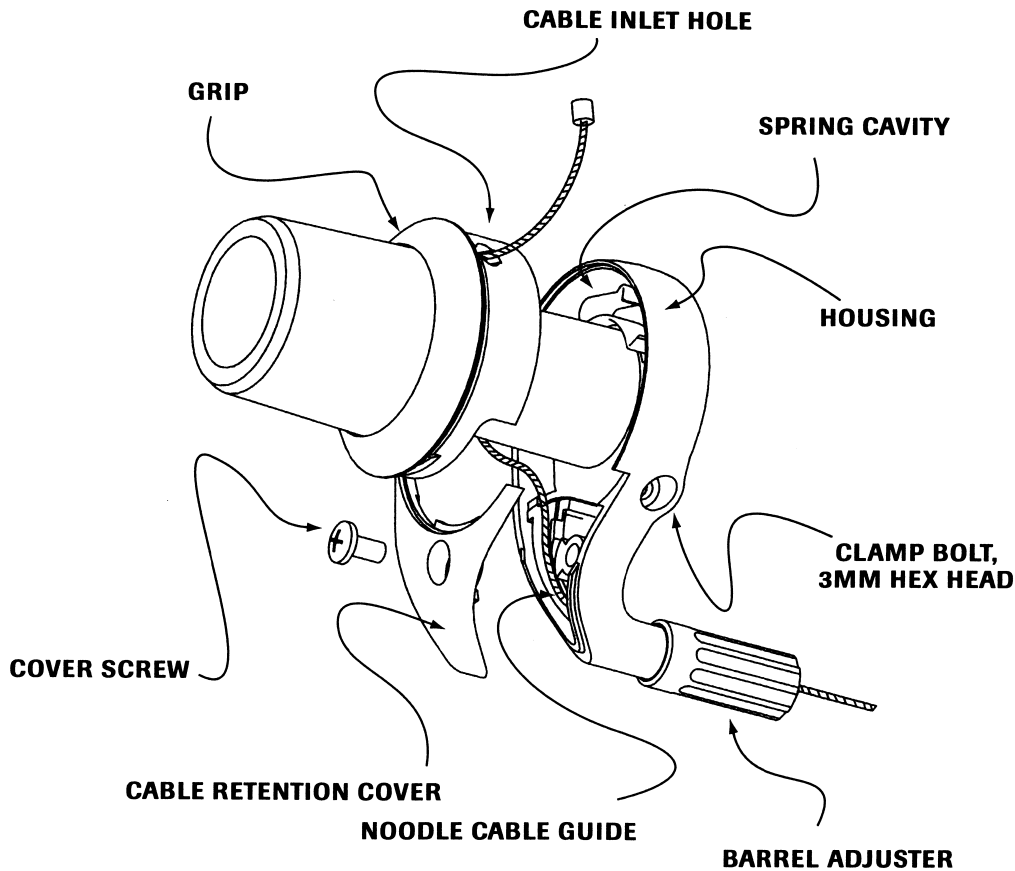

FRONT SHIFTER CABLE REPLACEMENT

cont'd

6 Install the new derailleur cable. Make sure the cable end-button is seated securely in the shifter GRIP, then replace the cable button retention screw. Thread the cable through the shifter HOUSING and out of the barrel adjuster.

6 Close shifter assembly by sliding the shifter GRIP back into the shifter HOUSING body (make sure the metal index spring is correctly seated in its cavity and that it slides into one of the GRIP detents). Be careful not to pinch the derailleur cable or dislodge the indexing spring

in the process.

7 Replace the cable retention cover plate and screw (be careful not to pinch the inboard seal or cable).

8 Check for proper assembly by rotating shifter grip and listening for clicks.

9 Thread the shifter barrel adjuster nut all the way in and back it off one half turn. Route the cable through the cable housing & frame; fasten to derailleur. Adjust for proper index shifting.

SRT 800 X-RAY & SRT 600

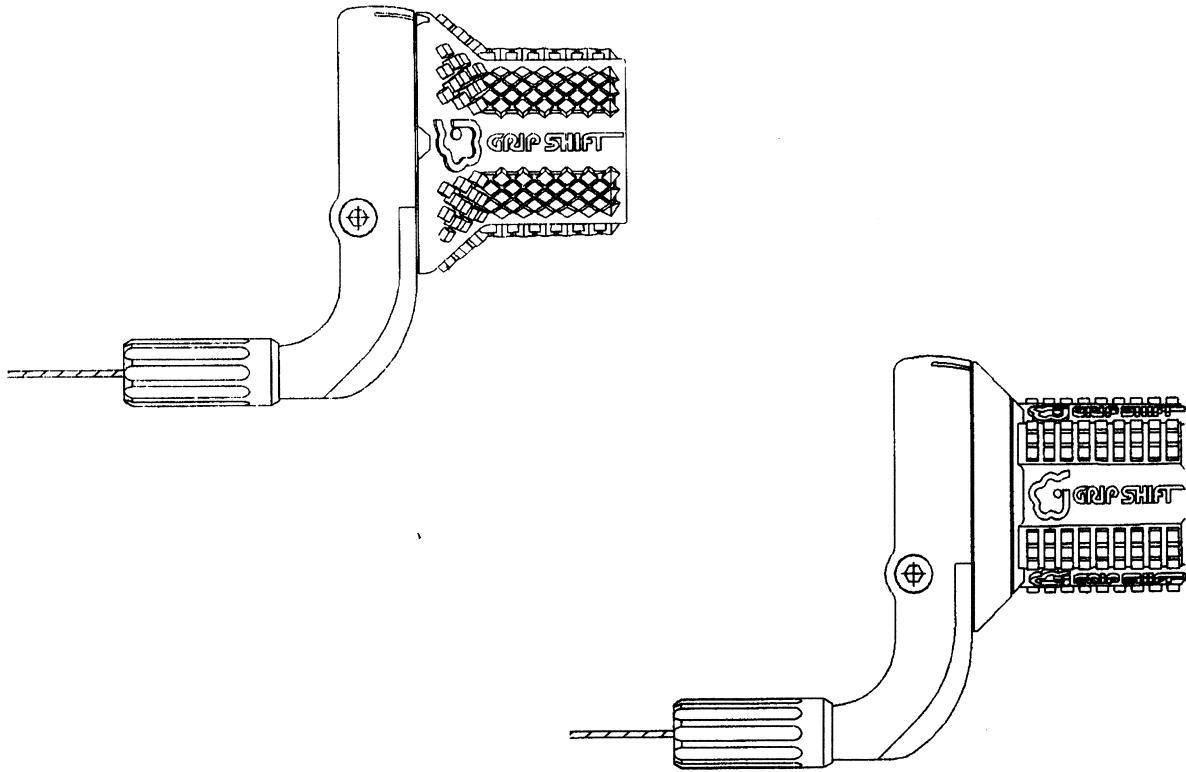

FEATURES

REAR SHIFTER SPEEDS	•••	<i>X-RAY 8 spd./ SRT 600 8 & 7 spd.</i>
FRONT SHIFTER OPTIONS	•••	<i>FFS FRICTION FRONT & INDEX FRONT¹</i>
SEALING	•••	<i>X-RAY DUAL SEALS/ SRT 600 SEALED</i>
CABLE	•••	<i>SRAM SS 1.1mm</i>
CLAMP STYLE	•••	<i>ALUM. "C", .875 INCH I.D.</i>
BARREL ADJUSTER	•••	<i>INDEXING</i>
GRIP COVER STYLE	•••	<i>X-RAY MONSTER PAW²/ SRT 600 MUD PAW</i>
SERVICE TOOLS REQUIRED	•••	<i>3MM HEX KEYS, PHILLPS HEAD SCREWDRIVER, JONNISNOT GREASE</i>

Notes

1. Index front is Shimano Dual SIS compatible
2. ESP and X-RAY shifters can share the same rubber grip covers



SRT 800 X-RAY & SRT 600 PARTS

Part#	Description	Part#	Description
SRT 800-11/81 ¹	24 spd. shifter system	600-401	index spring
SRT 600-11/81 ¹	24 spd. shifter system	200-213	X-RAY housing, rear ⁴
SRT 600-11/71 ¹	21 spd. shifter system	200-214	X-RAY housing front ⁴
SRT 800-81 X	8 spd. shifter	200-211	SRT 600 housing, rear ⁴
SRT 800-11 X	front friction shifter	200-212	SRT 600 housing front ⁴
SRT 800-32 X	front index shifter ²	200-248	rear grip, X-RAY 8spd ⁵
SRT 600-81	8 spd. shifter	200-246	front grip, X-RAY friction ⁵
SRT 600-71	7 spd. shifter	200-246	front grip, X-RAY index ⁵
SRT 600-11	front friction shifter	200-245	rear grip, SRT 600 8spd ⁵
SRT 600-32	front index shifter ²	200-244	rear grip, SRT 600 7spd ⁵
		200-242	front grip, SRT 600 friction ⁵
		200-243	front grip, SRT 600 index ⁵

REPLACEMENT PARTS

600-503	cover screw	700-802	SRAM SS cable, 1.1mm
600-502	clamping bolt	500-308	nylon washer
600-601	clamping collar/front	500-812	Monster Paw II, rubber grip cover ³
600-501	clamping collar/rear		
500-609	noodle/front	500-612	Mud paw II rubber grip cover ³
500-908	noodle/rear		
500-912	indexing barrell adjuster		
500-807	X-RAY cable cover/front		
500-806	X-RAY cable cover/rear		
500-607	SRT 600 cable cover/front		
500-505	SRT 600 cable cover/rear		
500-808	X-RAY outboard seal		
500-508	inboard rubber seal		

Notes

1. This is the *aftermarket kit system*: packaged shifter set including cables, GSR stationary grips, grease, washers, and assembly instructions.
2. Will work with DUAL SIS compatible componentry only.
3. Please see "Grip Cover " section in this manual for more rubber options
4. This assembly includes housing body, guide noodle, clamp & bolt, and barrel adjuster,
5. This assembly includes grip, rubber grip cover and inboard (and out board seals for the X-RAY)

SRT 800 X-RAY & SRT 600 REAR

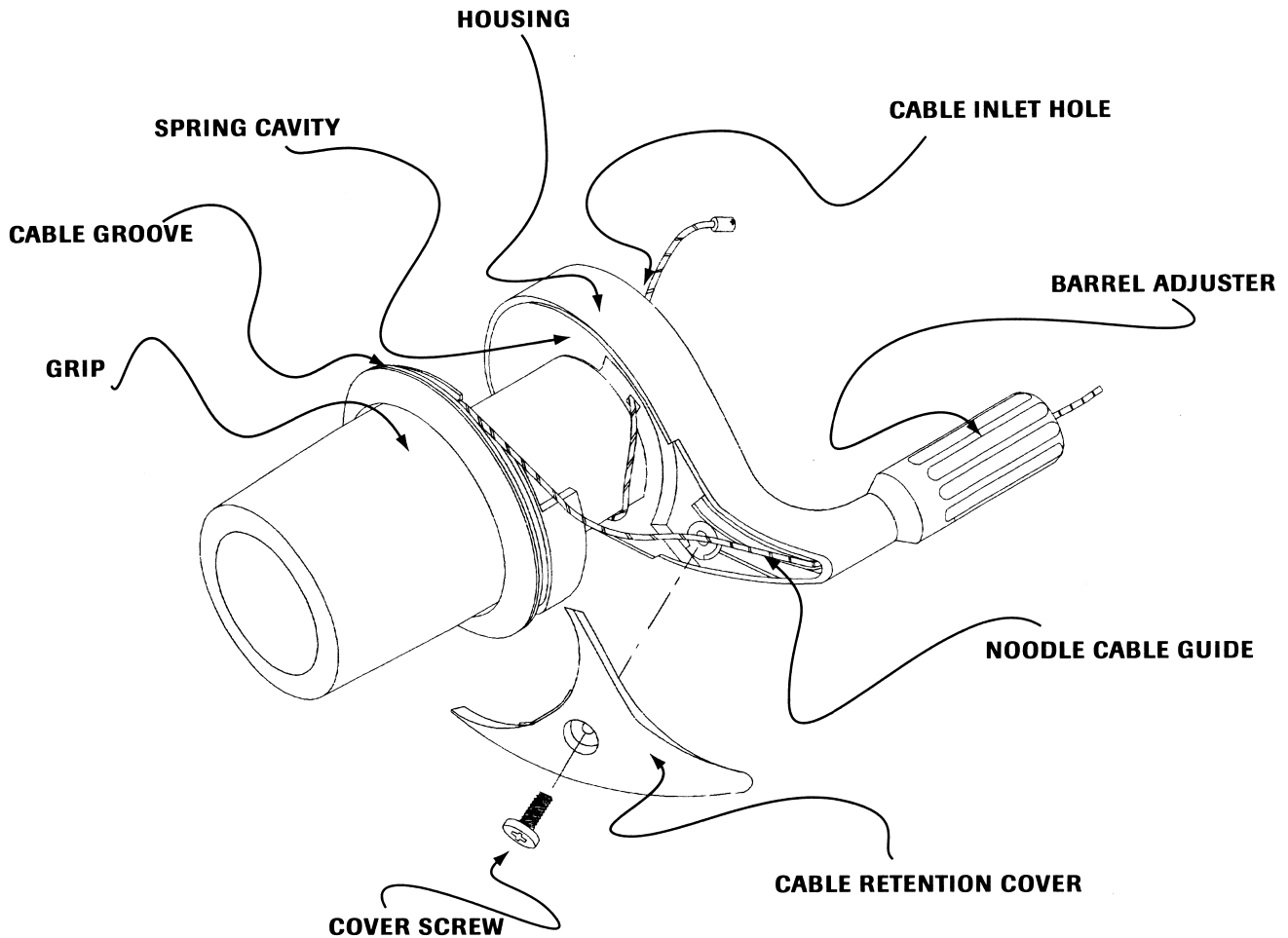

REAR SHIFTER CABLE REPLACEMENT

(note: for best results do not remove the shifter from the handlebar. Use only new and high quality cable and compression less housing.)

- 1 Rotate the shifter GRIP so that the chain positions into the smallest cog/chainring. Detach derailleur cable from the derailleur.
- 2 Slide the stationary grip and plastic washer away from shifter.
- 3 Remove the triangular cable retention cover plate using a Phillips head screwdriver: see diagram.
- 4 Open the shifter assembly by sliding the GRIP (and the loop of cable attached to it) away from the HOUSING body (note: the metal index spring may become dislodged in the process).
- 5 Remove and discard the old cable (be sure to wipe any debris from the cable before pulling it through the shifter). If the shifter interior is contaminated and/or requires lubrication refer to

"Clean and Lube".

- 6 Thread a new cable through the HOUSING via the cable inlet hole (as shown). Wrap the cable clockwise around the HOUSING tube and exit through the barrel adjuster; creating a single loop of cable (see diagram).
- 7 To close the shifter, push the GRIP back into the HOUSING, while pulling cable out from the barrel adjuster. Be sure the index spring is in place inside the housing and that it rides into a detent in the GRIP.
- 8 Replace the cable retention cover (be careful not to pinch the inboard seal or cable). Rotate the shifter GRIP and listen for proper indexing.
- 9 Thread the shifter barrel adjuster nut all the way in and back it off one half turn. Route the cable through the cable housing & frame; fasten to derailleur. Adjust for proper index shifting per the derailleur manufacturer instructions.

SRT 800 X-RAY & SRT 600 FRONT

CABLE INLET HOLE

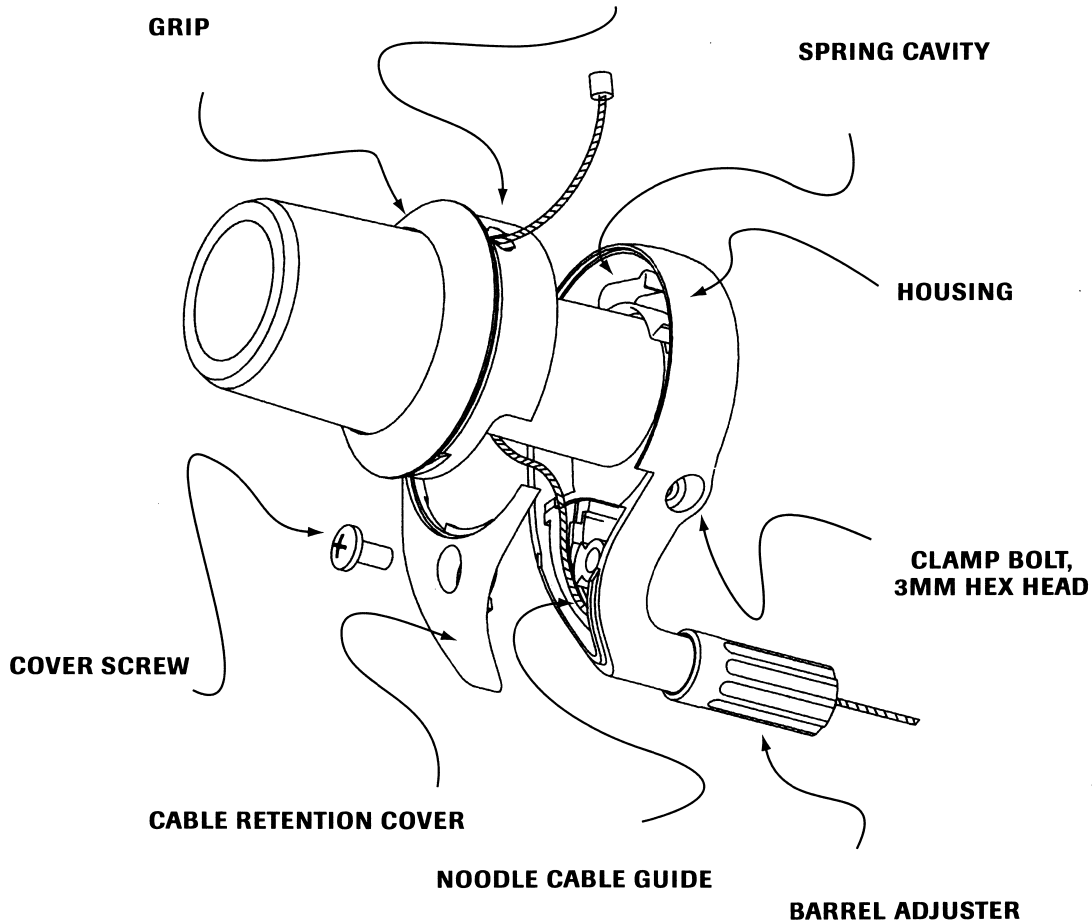

FRONT SHIFTER CABLE REPLACEMENT

- ❶ Follow the first five steps of "Rear De. Cable Change".
- ❷ Thread the cable through the cable inlet hole in the GRIP. Make sure the cable end button is seated securely in place, then route the cable directly out through the barrel adjuster.
- ❸ With the indexing spring in place, close the shifter, by pushing the GRIP back into the HOUSING while pulling cable out of the barrel adjuster (be sure the index spring rides into a detent in the GRIP). Follow steps 8 & 9 from "Rear Shifter Cable Change".

SRT 450

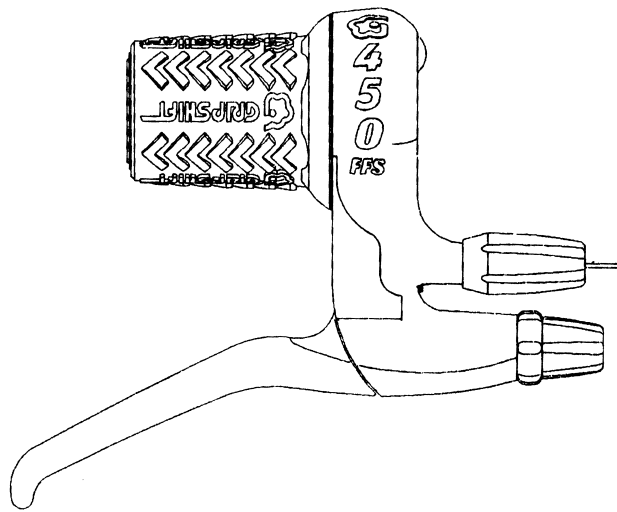

FEATURES

<p>REAR SHIFTER SPEEDS</p> <p>FRONT SHIFTER OPTIONS</p> <p>SEALING</p> <p>CABLE</p> <p>CLAMP STYLE</p> <p>BARREL ADJUSTER</p> <p>GRIP COVER STYLE</p> <p>SERVICE TOOLS REQUIRED</p>	<p>.....</p>	<p>7spd.</p> <p>FFS FRICTION FRONT & INDEX FRONT</p> <p>TREACHEROUS PATH</p> <p>DIE DRAWN 1.2mm</p> <p>ALUM. "C", .875 INCH I.D.</p> <p>FRICTION</p> <p>MTB ARROW DESIGN</p> <p>3mm HEX KEY,</p> <p>FLAT HEAD SCREWDRIVER,</p> <p>JONNISNOT GREASE</p>
---	--------------	--

Notes

1. Index front is Shimano Dual SIS compatible



SRT 450

Part#	Description
SRT 450-11/71	Shifter System ¹
SRT 450-71	rear shifter/brake 7 spd.
SRT 450-11	front friction shifter/brake
SRT 450-32	front index shifter/brake ²

REPLACEMENT PARTS

600-502	clamping bolt
600-461	reach adjustment screw
500-455	barrel adjuster, shifter
600-453	barrel adjuster bolt, brake
600-454	slotted lock nut, brake adjuster
600-451	clamp bracket, rear
600-452	clamp bracket, front
600-465	brake lever assembly, rear
600-466	brake lever assembly, front
500-453	cable cover/rear
500-454	cable cover/front
600-401	index spring
500-451	housing, rear
500-452	housing, front
500-403	rear grip, 7 spd
500-405	front grip, friction
500-404	front grip, index
700-802	cable, SRAM SS 1.1mm
500-308	nylon washer
500-411	MTB Arrow rubber grip cover

Notes

1. This is the *aftermarket kit system*: packaged shifter set including cables, MTB stationary grips, grease, washers, and assembly instructions.
2. Will work with DUAL SIS compatible componentry only.

SRT 450 REAR

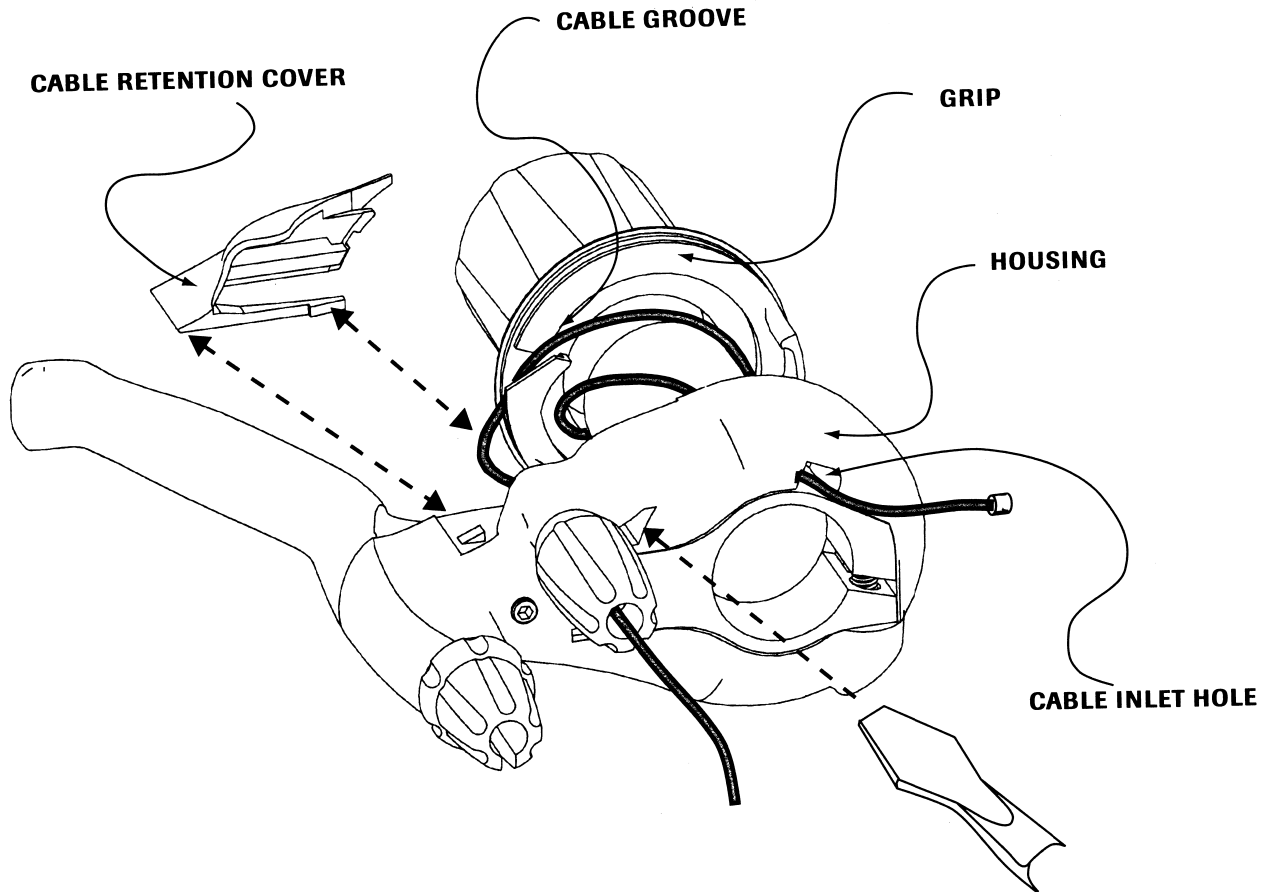

REAR SHIFTER CABLE REPLACEMENT

(note: for best results do not remove the shifters from the handlebar. Use only new and high quality cable and compression-less housing.)

- 1 Rotate the shifter GRIP so that the chain positions into the smallest cog/chainring. Detach derailleur cable from the derailleur.
- 2 Slide the stationary grip and plastic washer away from shifter.
- 3 Remove the cable retention cover plate using a flat head screwdriver: see diagram.
- 4 Open the shifter assembly by sliding the GRIP (and the loop of cable attached to it) away from the HOUSING body (note: the metal index spring may become dislodged in the process).
- 5 Remove and discard the old cable (be sure to wipe any debris from the cable before pulling it through the shifter). If the shifter

interior is contaminated and/or requires lubrication refer to "Clean and Lube".

- 6 Thread a new cable through the HOUSING via the cable inlet hole (as shown). Wrap the cable clockwise around the HOUSING tube and exit through the barrel adjuster; creating a single loop of cable (see diagram).
- 7 Align #7 on the GRIP with the gear indication stripe on the HOUSING and feed the cable loop onto the cable groove of the GRIP at this location. To close the shifter, push the GRIP back into the HOUSING, while pulling cable out from the barrel adjuster. Be sure the index spring is in place inside.
- 8 Replace the cable retention cover. Rotate the shifter GRIP and listen for proper indexing.
- 9 Re-attach cable to the rear derailleur and adjust indexing per the derailleur manufacturer instructions.

SRT 450 FRONT

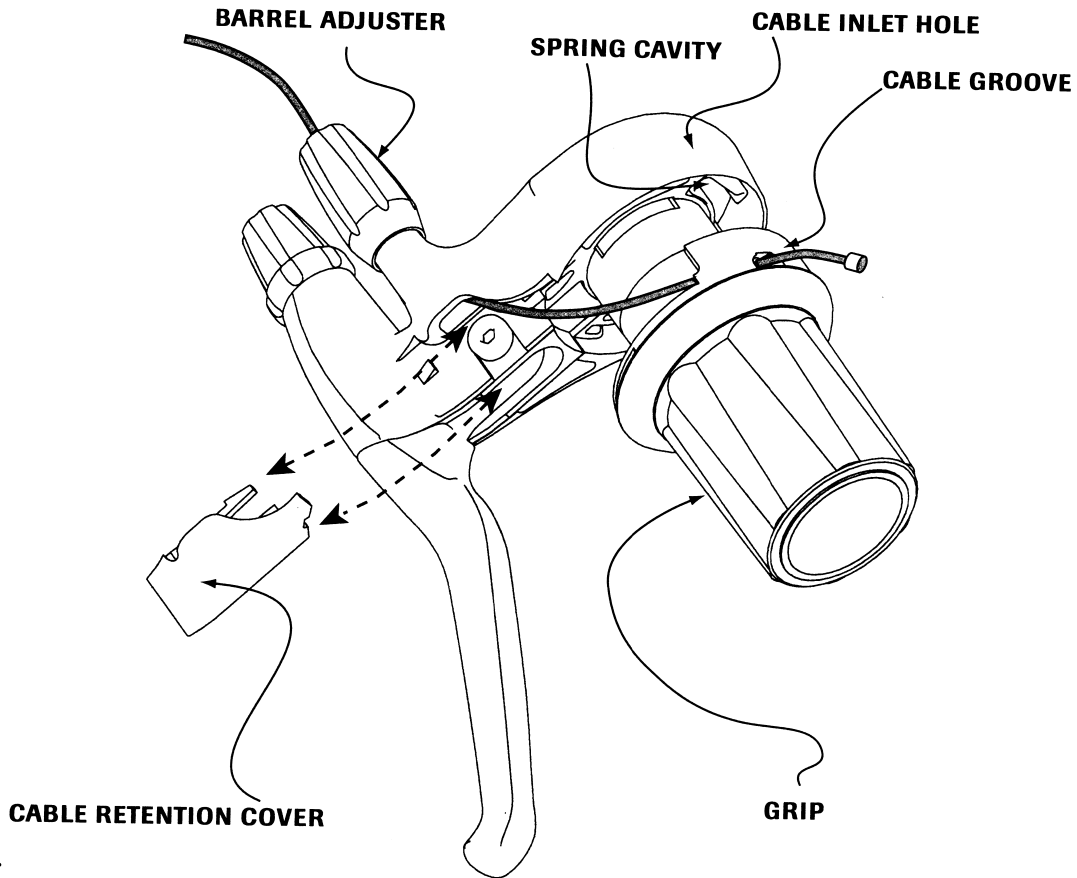

FRONT SHIFTER CABLE REPLACEMENT

- 1 Follow the first five steps of "Rear shifter Cable Replacement".
- 2 Thread the cable through the cable inlet hole in the GRIP. Make sure the cable end button is seated securely in place, then route the cable directly out through the barrel adjuster.
- 3 With the index spring in place, align the #1 on the GRIP with the gear indication stripe on the HOUSING. To close the shifter, push the GRIP back into the HOUSING while pulling cable out of the barrel adjuster. Follow steps 8 & 9 from "Rear Shifter Cable Replacement".



SRT 400

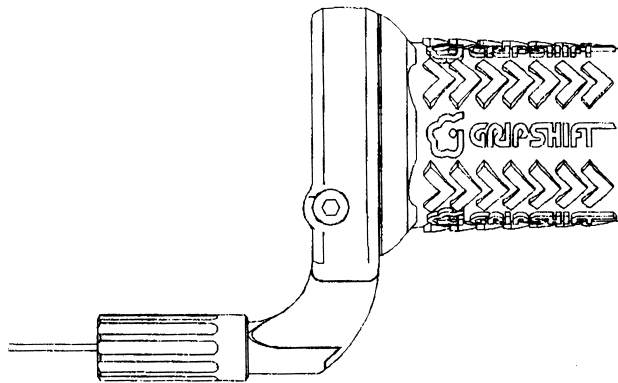

FEATURES

REAR SHIFTER SPEEDS	7 spd.
FRONT SHIFTER OPTIONS	FFS FRICTION FRONT & INDEX FRONT ¹
SEALING	TREACHEROUS PATH
CABLE	DIE DRAWN 1.2mm
CLAMP STYLE	ALUM. "C", .875 INCH I.D.
BARREL ADJUSTER	FRICTION
GRIP COVER STYLE	MTB ARROW DESIGN
SERVICE TOOLS REQUIRED	3mm HEX KEY, FLAT HEAD SCREWDRIVER, JONNISNOT GREASE

Notes

1. Index front is Shimano Dual SIS compatible



SRT 400

Part#	Description
SRT 400-11/71	Shifter System ¹
SRT 400-71	rear shifter 7 spd.
SRT 400-11	front friction shifter
SRT 400-32	front index shifter ²

REPLACEMENT PARTS

600-502	clamping bolt
500-506	barrel adjuster
600-601	clamp, rear
600-501	clamp, front
500-406	cable cover/rear
500-407	cable cover/front
600-401	index spring
200-209	housing, rear ³
200-210	housing, front ³
200-237	rear grip, 7 spd ⁴
200-235	front grip, friction ⁴
200-236	front grip, index ⁴
700-802	cable, SRAM SS 1.1mm
500-308	nylon washer
500-411	MTB Arrow rubber grip cover

Notes

1. This is the *aftermarket kit system*: packaged shifter set including cables, MTB stationary grips, grease, washers, and assembly instructions.
2. Will work with DUAL SIS compatible componentry only.
3. This assembly includes housing body, clamp & bolt, and barrel adjuster.
4. This assembly includes grip, rubber grip cover.

SRT 400 REAR

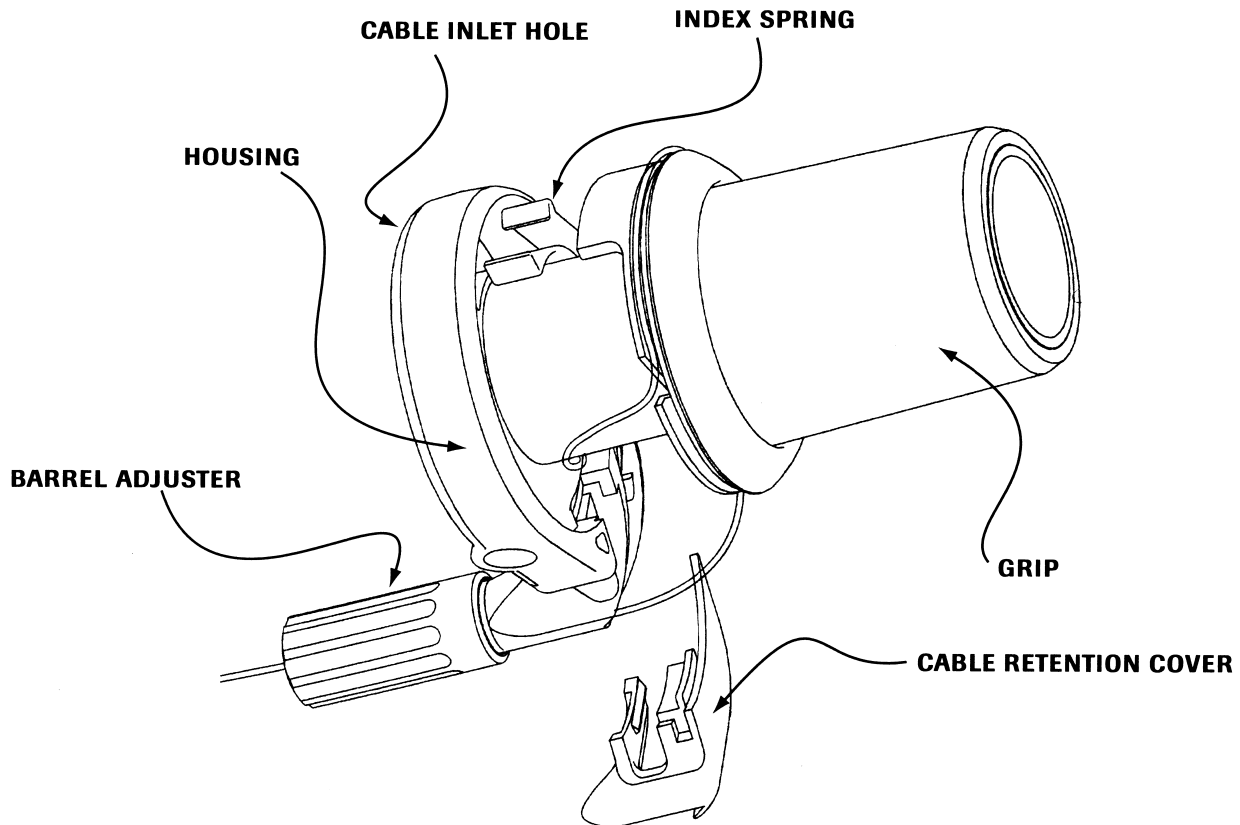

REAR SHIFTER CABLE REPLACEMENT

(note: for best results do not remove the shifters from the handlebar. Use only new and high quality cable and compressionless housing.)

- 1 Rotate the shifter GRIP so that the chain positions into the smallest cog/chainring. Detach derailleur cable from the derailleur.
- 2 Slide the stationary grip and plastic washer away from shifter.
- 3 Remove the cable retention cover plate using a flat head screwdriver: see diagram on opposite page..
- 4 Open the shifter assembly by sliding the GRIP (and the loop of cable attached to it) away from the HOUSING body (note: the metal index spring may become dislodged in the process).
- 5 Remove and discard the old cable (be sure to wipe any debris from the cable before pulling it through the shifter). If the shifter

interior is contaminated and/or requires lubrication refer to "Clean and Lube".

- 6 Thread a new cable through the HOUSING via the cable inlet hole (as shown). Wrap the cable clockwise around the HOUSING tube and exit through the barrel adjuster; creating a single loop of cable (see diagram).
- 7 Align #7 on the GRIP with the gear indication stripe on the HOUSING and feed the cable loop onto the cable groove of the GRIP at this location. To close the shifter, push the GRIP back into the HOUSING, while pulling cable out from the barrel adjuster. Be sure the index spring is in place inside.
- 8 Replace the cable retention cover. Rotate the shifter GRIP and listen for proper indexing. Re-attach cable to the rear derailleur and adjust indexing per the derailleur manufacturer instructions.

SRT 400 FRONT

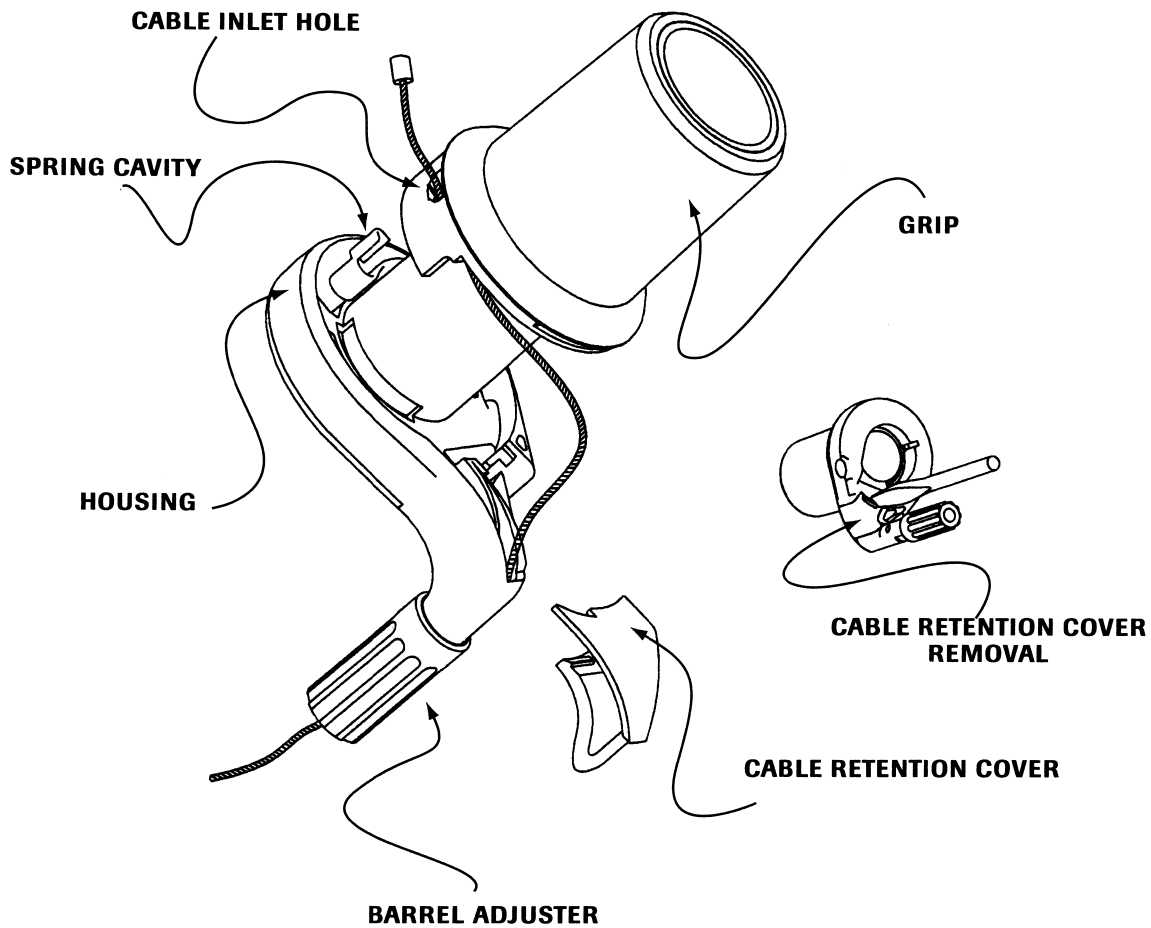

FRONT SHIFTER CABLE REPLACEMENT

- 1 Follow the first five steps of "Rear Shifter Cable Replacement".
- 2 Thread the cable through the cable inlet hole in the GRIP. Make sure the cable end button is seated securely in place, then route the cable directly out through the barrel adjuster.
- 3 With the index spring in place, align the #1 on the GRIP with the gear indication stripe on the HOUSING. To close the shifter, push the GRIP back into the HOUSING while pulling cable out of the barrel adjuster. Follow steps 8 & 9 from "Rear Shifter Cable Replacement".

SRT 300i

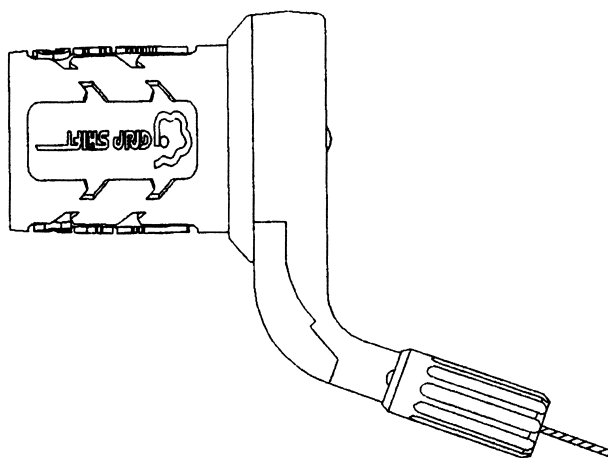

FEATURES

REAR SHIFTER SPEEDS	7 spd.
FRONT SHIFTER OPTIONS	FRICION FRONT & INDEX FRONT ¹
SEALING	TREACHEROUS PATH
CABLE	DIE DRAWN 1.2mm
CLAMP STYLE	ALUM., "POKE" .875 INCH I.D.
BARREL ADJUSTER	FRICION
GRIP COVER STYLE	CONTOUR DESIGN
SERVICE TOOLS REQUIRED	2.5mm HEX KEY, FLAT HEAD SCREWDRIVER, JONNISNOT GREASE

Notes

1. Index front is Shimano Dual SIS compatible



SRT 300i

Part#	Description
<i>REPLACEMENT PARTS</i>	
600-304-1	clamp set screw
500-506	barrel adjuster
600-211	clamp front/rear
500-363	cable cover/rear
500-364	cable cover/front
600-102	metal index spring ¹
200-205	housing, rear ³
200-206	housing, front ³
200-234	rear grip, 7 spd ⁴
200-232	front grip, friction ⁴
200-233	front grip, index ^{2&4}
700-802	cable, SRAM SS 1.1mm
500-308	nylon washer
500-344	Contour rubber grip cover
500-411	MTB Arrow rubber grip cover

Notes

1. This is a new part for the SRT 300i. Pre-1996 SRT 200i & 300i models can only use plastic springs, part # 500-318
2. Will work with DUAL SIS compatible componentry only.
3. This assembly includes housing body, clamp & bolt, and barrel adjuster.
4. This assembly includes grip, rubber grip cover.

SRT 300i REAR

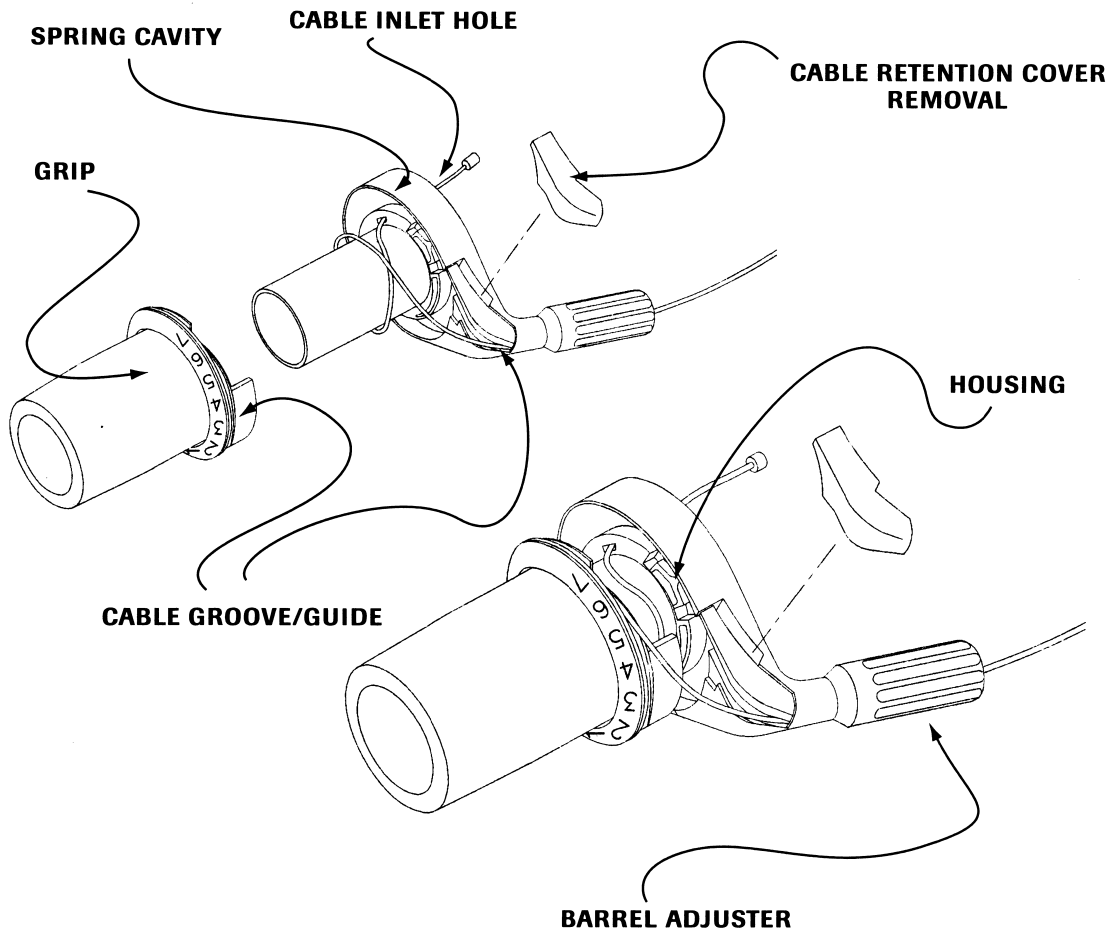

REAR SHIFTER CABLE REPLACEMENT

(note: for best results do not remove the shifters from the handlebar. Use only new and high quality cable and compression-less housing.)

- 1 Rotate the shifter GRIP so that the chain positions into the smallest cog/chainring. Detach derailleur cable from the derailleur.
- 2 Slide the stationary grip and plastic washer away from shifter.
- 3 Remove the cable retention cover plate using a flat head screwdriver: see diagram.
- 4 Open the shifter assembly by sliding the GRIP (and the loop of cable attached to it) away from the HOUSING body (note: the index spring may become dislodged in the process).
- 5 Remove and discard the old cable (be sure to wipe any debris from the cable before pulling it through the shifter). If the shifter

interior is contaminated and/or requires lubrication refer to "Clean and Lube".

- 6 Thread a new cable through the HOUSING via the cable inlet hole (as shown). Wrap the cable clockwise around the HOUSING tube and exit through the barrel adjuster; creating a single loop of cable (see diagram).
- 7 Align #7 on the GRIP with the gear indication stripe on the HOUSING and feed the cable loop onto the cable groove of the GRIP at this location. To close the shifter, push the GRIP back into the HOUSING, while pulling cable out from the barrel adjuster. Be sure the index spring is in place inside.
- 8 Replace the cable retention cover. Rotate the shifter GRIP and listen for proper indexing.
- 9 Re-attach cable to the rear derailleur and adjust indexing per the derailleur manufacturer instructions.



SRT 300i FRONT

FRONT SHIFTER CABLE REPLACEMENT

- ❶ Follow the first five steps of "Rear Shifter Cable Replacement".
- ❷ Thread the cable through the cable inlet hole in the HOUSING
- ❸ With the index spring in place, align the #1 on the GRIP with the gear indication stripe on the HOUSING. To close the shifter, push the GRIP back into the HOUSING while pulling cable out of the barrel adjuster. Follow steps 8 & 9 from "Rear Shifter Cable Change".



MRX 100 & QUICK SHIFT

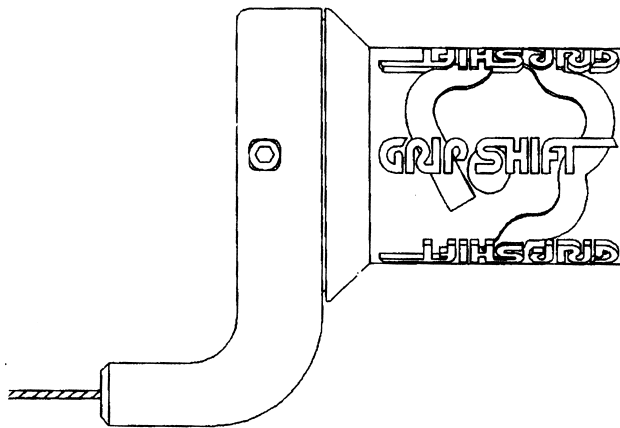

FEATURES

REAR SHIFTER SPEEDS	•••••	<i>MRX 100 7 spd/ QUICK SHIFT 6 & 5 spd</i>
FRONT SHIFTER OPTIONS	•••••	<i>FRICTION FRONT & INDEX FRONT¹</i>
SEALING	•••••	<i>TREACHEROUS PATH</i>
CABLE	•••••	<i>MRX 100-DIE DRAWN 1.2mm/ Q.S.-STEEL</i>
CLAMP STYLE	•••••	<i>ALUM., "POKE" .875 INCH I.D.</i>
BARREL ADJUSTER	•••••	<i>FRICTION</i>
GRIP COVER STYLE	•••••	<i>LOGO DESIGN</i>
SERVICE TOOLS REQUIRED	•••••	<i>2.5mm HEX KEY, JONNISNOT GREASE</i>

Notes

1. Index front is Shimano Dual SIS compatible.



MRX 100 & QUICKSHIFT

Part#	Description
MRX 100-11/71	Shifter System ¹
QUICKSHIFT-11/61	Shifter System ¹
QUICKSHIFT-11/51	Shifter System ¹
MRX 100-71	rear shifter 7 spd.
MRX 100-11	front friction shifter
MRX 100-32	front index shifter ²
QS 60-61	rear shifter 6 spd.
QS 60-51	rear shifter 5 spd.
QS 60-11	front friction shifter

REPLACEMENT PARTS

500-506	barrel adjuster, front
600-304-1	clamp set screw
600-211	clamp front/rear
600-102	metal index spring
200-201	housing, rear
200-202	housing, front ³
200-227	MRX 100 rear grip, 7 spd. ⁴
200-223	MRX 100 front grip, friction ⁴
200-224	MRX 100 front grip, index ⁴
200-222	QS 60-61 rear grip, 6 spd. ⁴
200-221	QS 60-51, 5 spd. ⁴
700-802	cable, SRAM SS 1.1mm
500-308	nylon washer
500-120	Logo rubber grip cover

Notes

1. This is the *aftermarket kit system*: packaged shifter set including cables, stationary grips, grease, washers, and assembly instructions.
2. Will work with DUAL SIS compatible componentry only.
3. This assembly includes housing body, clamp & bolt, and barrel adjuster.
4. This assembly includes grip & rubber grip cover.

MRX 100 & QUICK SHIFT

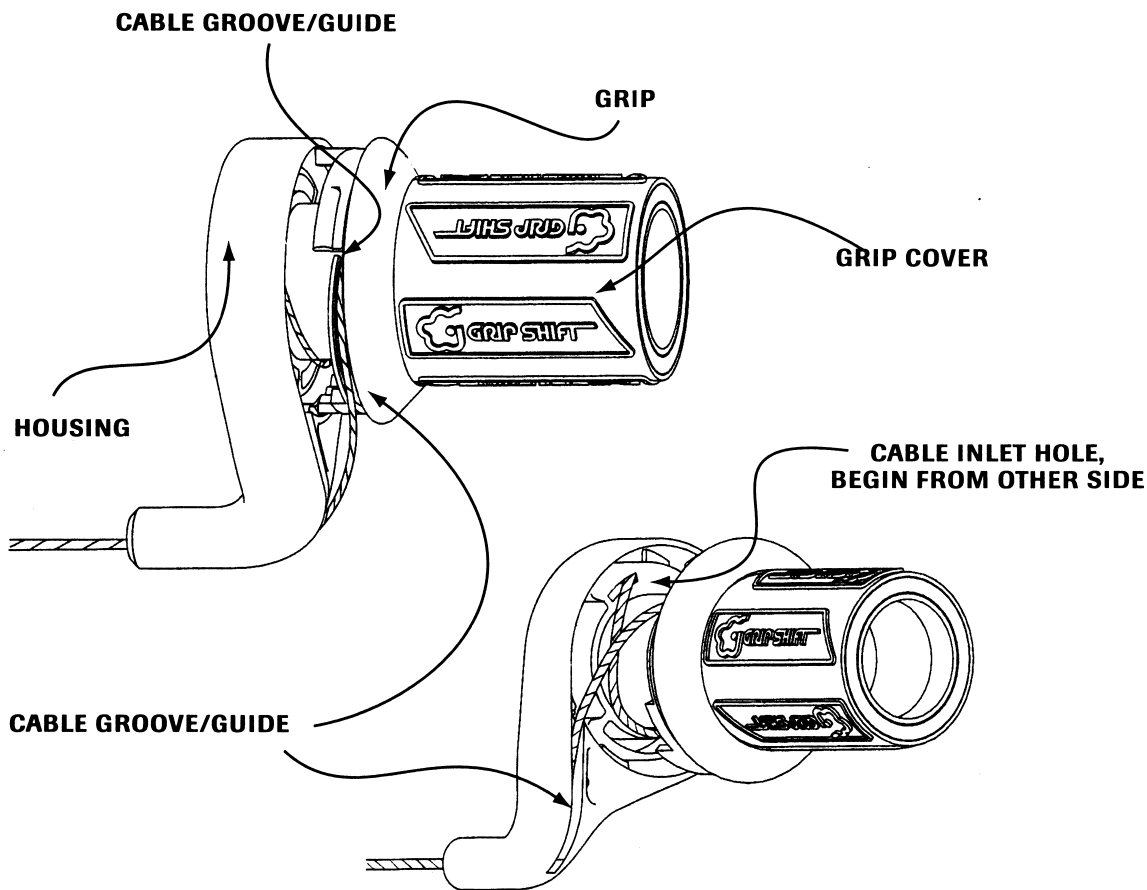

REAR SHIFTER CABLE REPLACEMENT

(note: for best results do not remove the shifters from the handlebar. Use only new and high quality cable and compression-less housing.)

- 1 Slide the stationary grip and plastic washer 3 inches or more away from the shifter.
- 2 Detach derailleur cable from the derailleur. Rotate the shifter GRIP to pull the maximum amount of cable into the shifter. With the shifter HOUSING still clamped to the handlebar, carefully unsnap the GRIP by pulling it outboard: be sure not to twist the shifter during this motion (note: the metal index spring may become dislodged in the process).
- 3 Remove and discard the old cable (be sure to wipe any debris from the cable before pulling it through the shifter). If the shifter interior is contaminated and/or requires lubrication refer to "Clean and Lube".

- 4 Thread a new cable through the HOUSING via the cable inlet hole (as shown). Wrap the cable clockwise around the HOUSING tube and exit through the barrel adjuster; creating a single loop of cable (see diagram).
- 5 Be sure the metal index spring is in position.
- 6 Align #7 (#6, #5 for Quick Shift 6 or 5 spd) on the GRIP with the gear indication stripe on the HOUSING and feed the cable loop onto the cable groove of the GRIP at this location. Begin closing the shifter by pushing the GRIP back towards the HOUSING, while pulling cable out from the barrel adjuster: you will find/feel a distinct spot when the GRIP is in the correct position. Completed reassembly will result in an audible "snap".
- 7 Rotate the shifter GRIP and listen for proper indexing.
- 8 Re-attach cable to the rear derailleur and adjust indexing per the derailleur manufacturer instructions.



MRX 100 & QUICK SHIFT

FRONT SHIFTER CABLE REPLACEMENT

- ❶ Slide the stationary grip and plastic washer 3 inches or more away from the shifter.
- ❷ Detach derailleur cable from the derailleur. Rotate the shifter GRIP to pull the maximum amount of cable into the shifter. With the shifter HOUSING still clamped to the handlebar, carefully unseat/unsnap the GRIP by pulling it outboard: be sure not to twist the shifter during this motion (note: the metal index spring may become dislodged in the process).
- ❸ Remove and discard the old cable (be sure to wipe any debris from the cable before pulling it through the shifter). If the shifter interior is contaminated and/or requires lubrication refer to "Clean and Lube".
- ❹ Thread a new cable through the HOUSING via the cable inlet hole (as shown). Wrap the cable clockwise around the HOUSING tube and exit through the barrel adjuster; creating a single loop of cable (see diagram).
- ❺ Be sure the metal index spring is in position.
- ❻ Align #1 on the GRIP with the gear indication stripe on the HOUSING and feed the cable loop onto the cable groove of the GRIP at this location. Begin closing the shifter by pushing the GRIP back towards the HOUSING, while pulling cable out from the barrel adjuster: you will find/feel a distinct spot when the GRIP is in the correct position. Completed reassembly will result in an audible "snap".
- ❼ complete steps 7 & 8 from Rear Shifter Cable Replacement.

GRIP COVER INSTALLATION

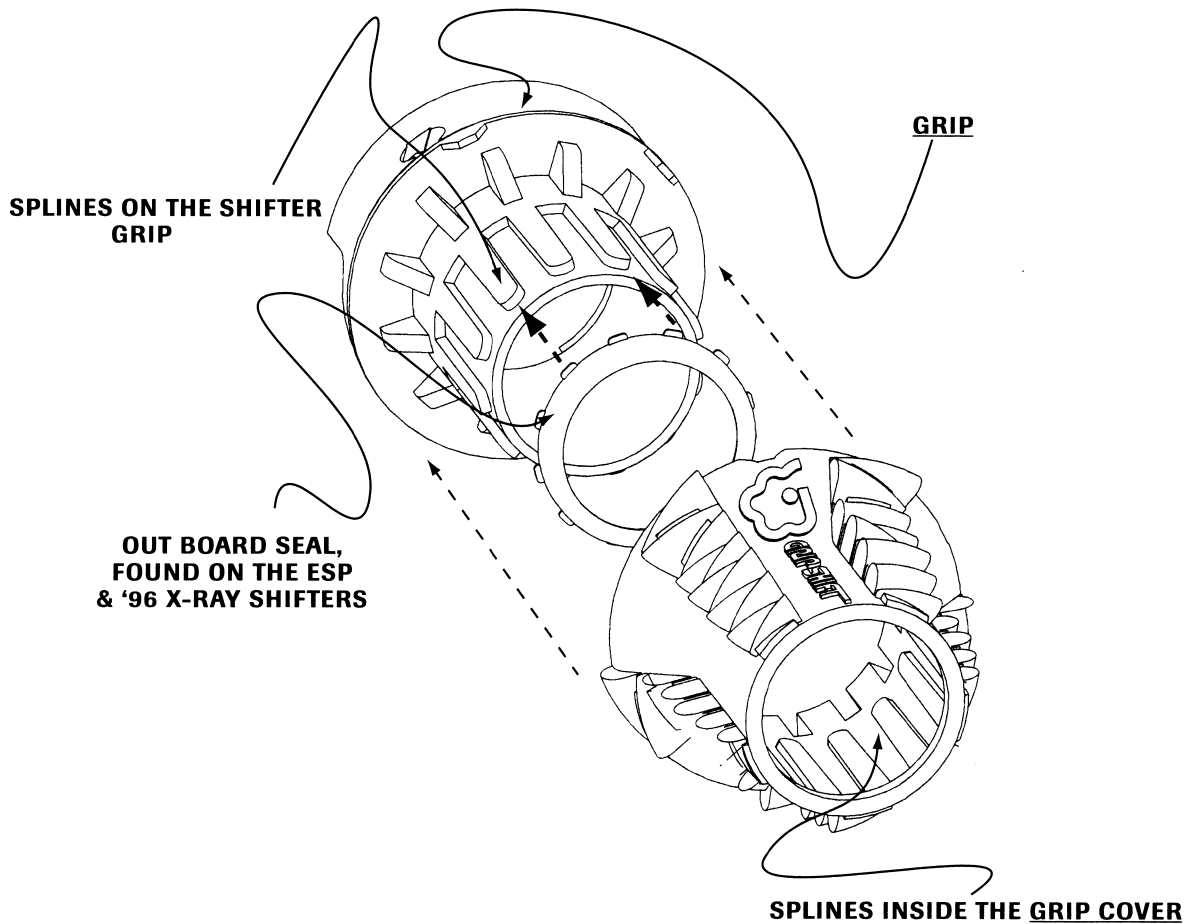

WHAT TO KNOW...

All model SRT shifters are designed to allow simple replacement of their rubber grip covers. See our 1996 product brochure for high performance replacement rubber for shifter models ESP 900, SRT 800 X-RAY, and SRT 600.

Caution: do not use any alcohol, solvents, hair sprays or lubricants to replace any Grip Shift grip covers, stationary grips or replacements of the same manufactured by others. These additives may damage the rubber compounds and/or the plastics in the shifters.

- ❶ Grip covers can be removed by simply sliding them away, along the molded splines, from the shifter grip. Use only compressed air or water to aid removal.
- ❷ To install new grip covers, soften the rubber in warm water and once again align the molded splines of both parts. Slide into place. For ESP 900 and SRT 800 X-RAY models be sure to match the gear indication notches of both parts.

THE BASSWORM SEAL

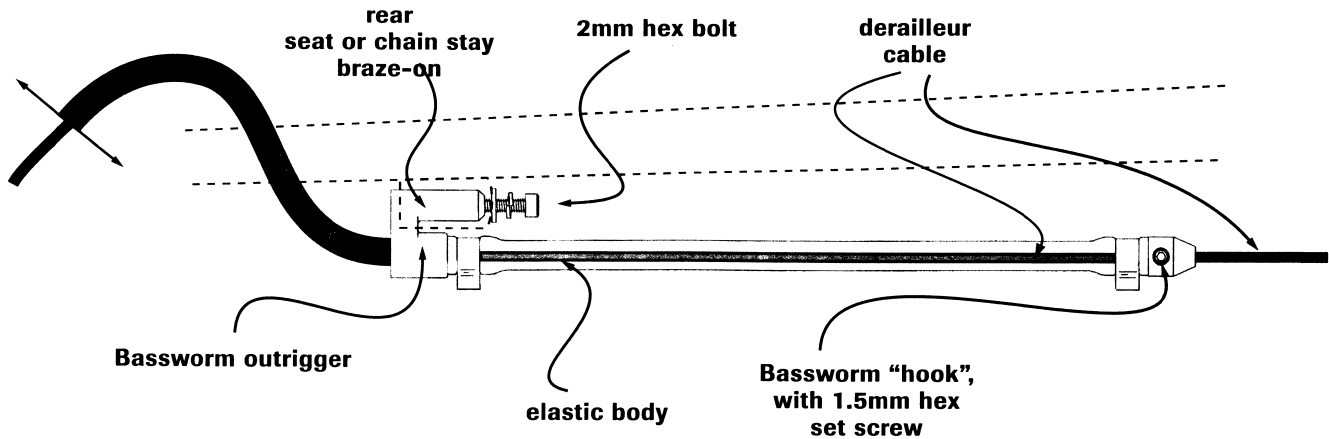

SEAL INSTALLATION AND CARE

- ❶ For best results, start with a new derailleur cable and cable housing.
- ❷ Using a 2mm hex key, secure the BASSWORM's "outrigger" to the rear cable housing braze-on (see diagram) so that there is no play. Be sure to keep the BASSWORM's body away from moving parts/pedaling motion.
- ❸ Thread derailleur cable through the BASSWORM
- ❹ Thread derailleur cable through rear piece of cable housing. Then insert cable housing into the "outrigger" of the BASSWORM and into the derailleur.
- ❺ Attach the derailleur cable to the derailleur and adjust rear indexing per manufacturers specifications.
- ❻ To gain pre-load tension on the derailleur cable shift the chain into the smallest cog. Stretch the front fitting, "hook", of the BASSWORM 1 to 2 inches and secure in place with a 1.5mm hex key (be sure that the "hook" does not interfere with any braze-ons or cable guides during shifting)
- ❼ Complete optimum sealing of the BASSWORM by placing a dab of grease onto the front end of the "hook".
- ❽ Check for proper indexing and re-adjust derailleur if necessary.



A series of 25 horizontal lines, evenly spaced, intended for writing or drawing.



A series of 25 horizontal black lines, evenly spaced, intended for writing.



A series of 25 horizontal lines, evenly spaced, intended for writing or drawing.



SRAM Corporation is a company based in Chicago, Illinois U.S.A. We are dedicated to designing, manufacturing and marketing high quality & high value bicycle components. Our product development group continues to improve and expand our component lines in great part through the input and influence of your opinions as dealers, racers and consumers.

Thank you and we welcome your comments and suggestions.