

# BB-M950

# Bottom Bracket

Before use, read these instructions carefully, and follow them for correct use.

## Installing the BB-M950

When installing the BB-M950, the correct combination of the three types of spacer must be used in accordance with the type of front derailleur, the bottom bracket shell width and the specified chain line. Refer to cases A to F in the table below to choose the correct combination of spacers.

Front derailleur	Front chainwheel	47.5 mm chain line		50 mm chain line	
		68mm (BC1.37)	73mm (BC1.37)	68mm (BC1.37)	73mm (BC1.37)
FD-M950 (band type)	FC-M950	A	B	C	D
FD-M950-E (bracket type)		E			F

### ● FD-M950 (Band type)

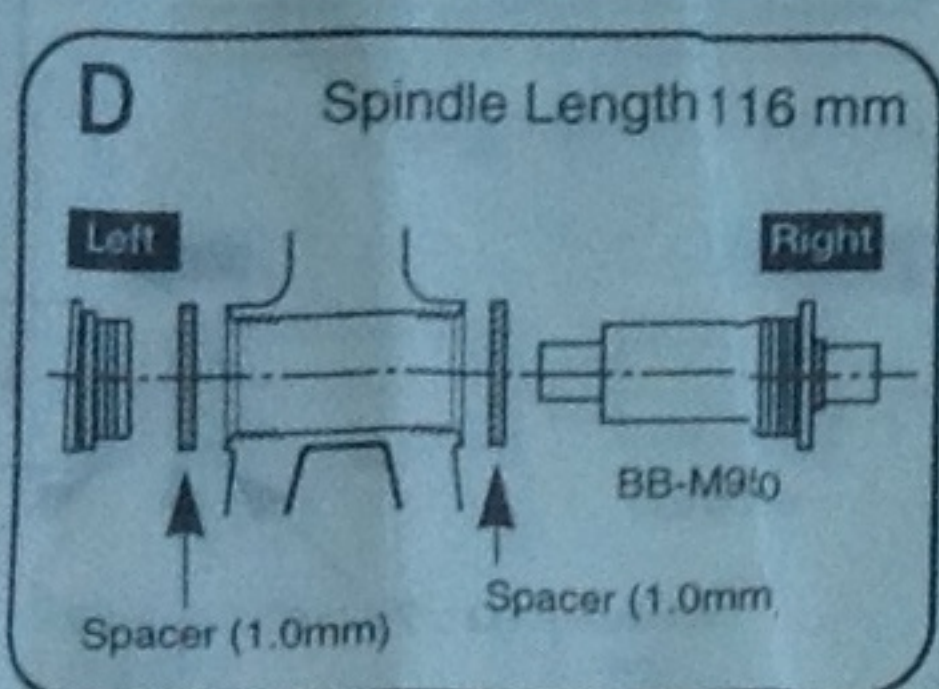
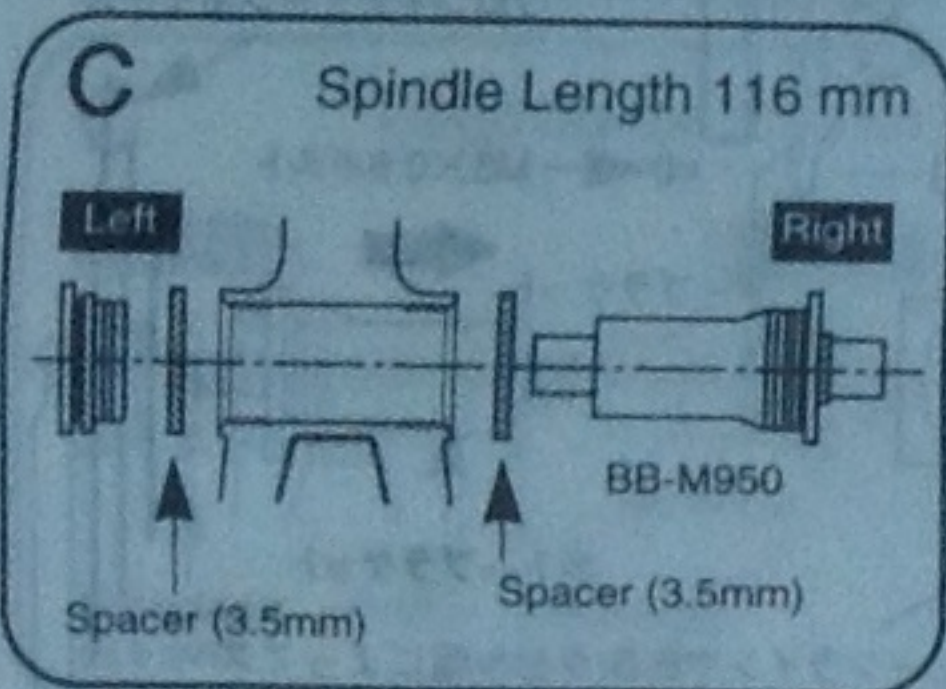
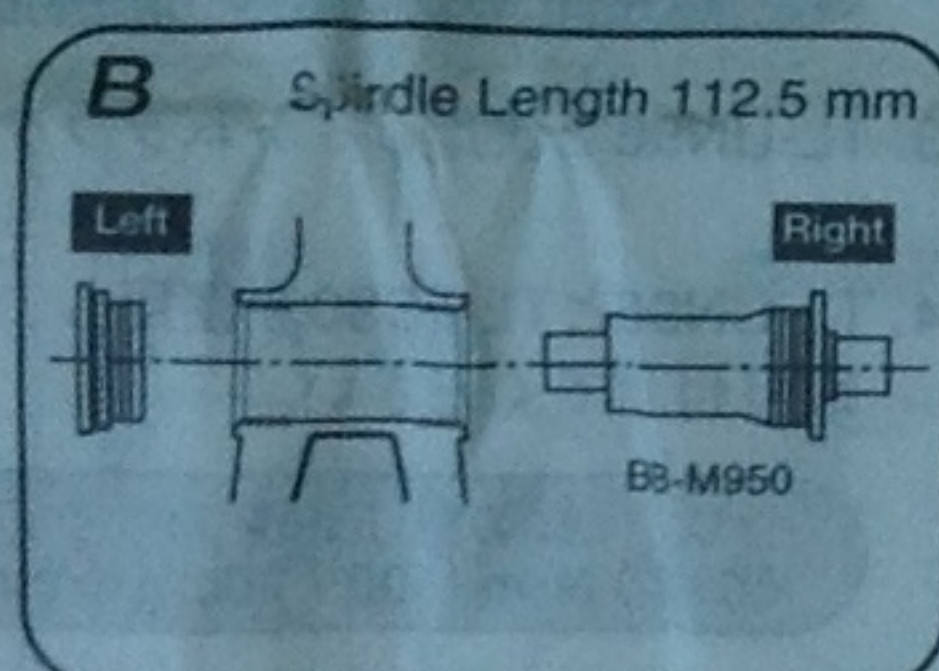
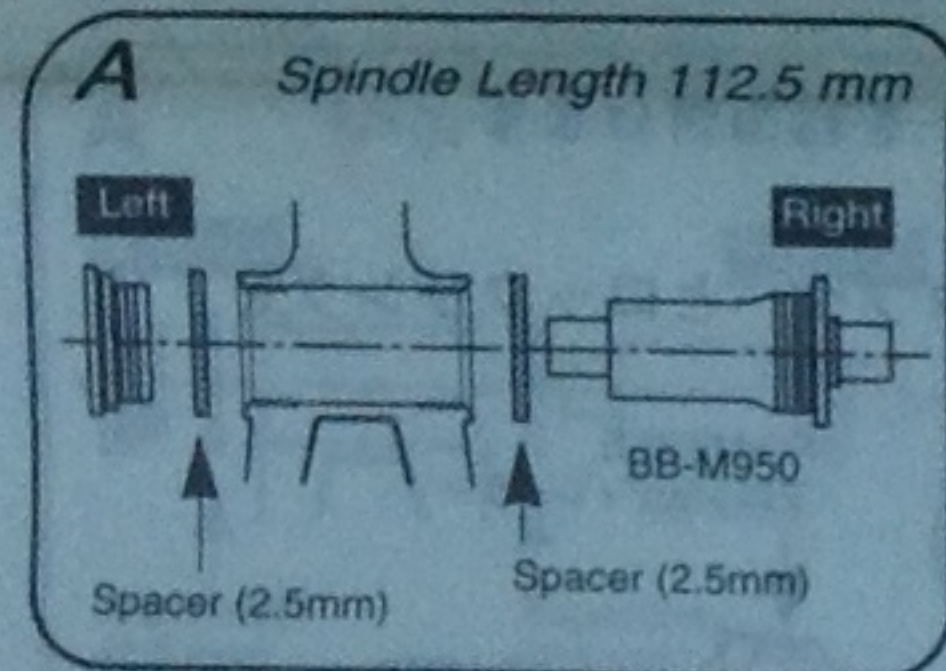

### ● FD-M950-E (Bracket type)

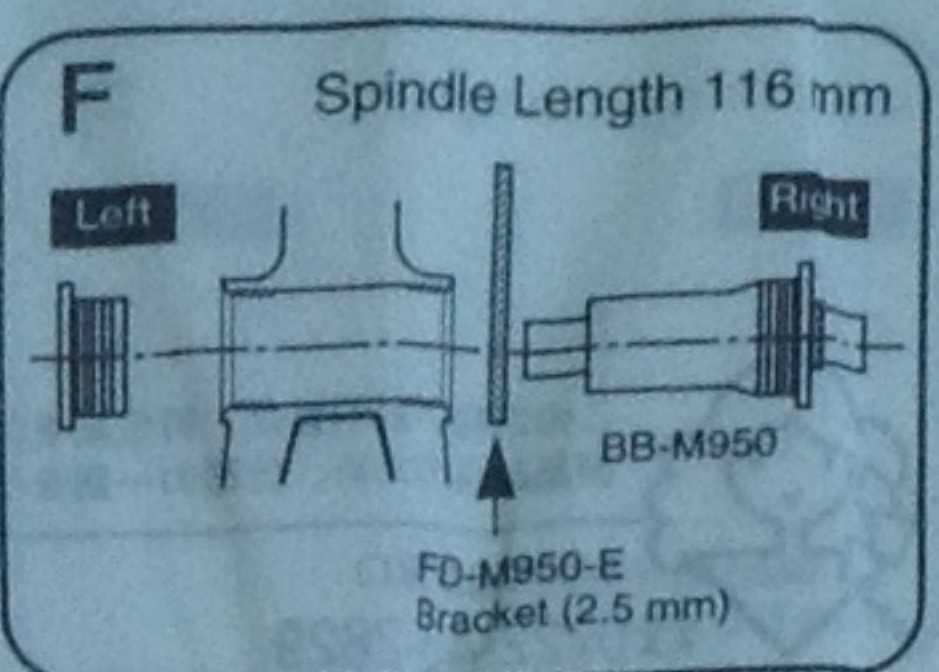
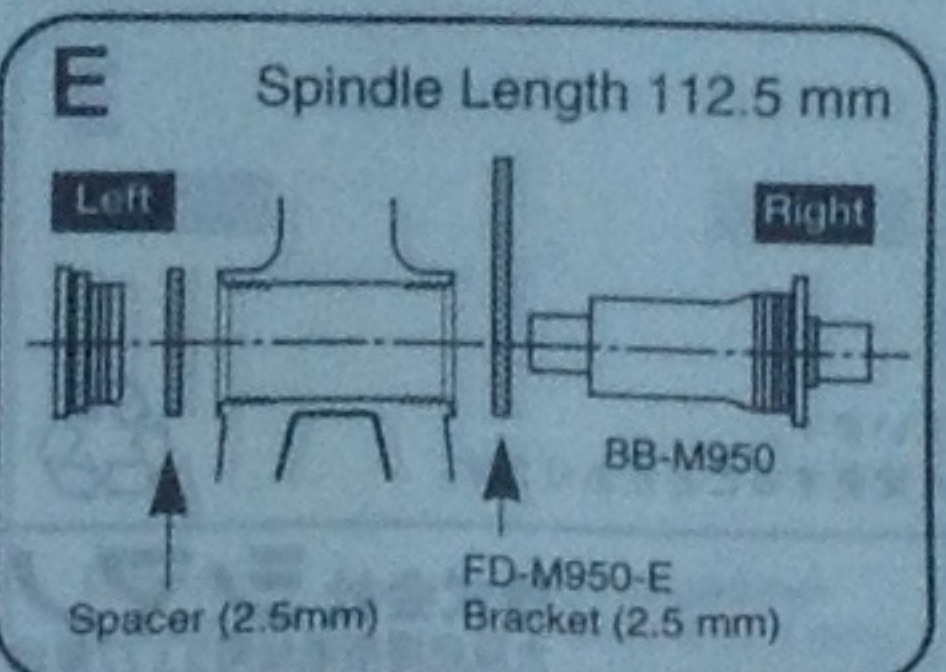

## Removing the left-hand adapter unit

1. While pushing in the right-hand adapter unit as shown in Fig. 1, remove the left-hand adapter unit. (Refer to Fig. 2.) Be careful not to hold the inner cover too firmly at this time.

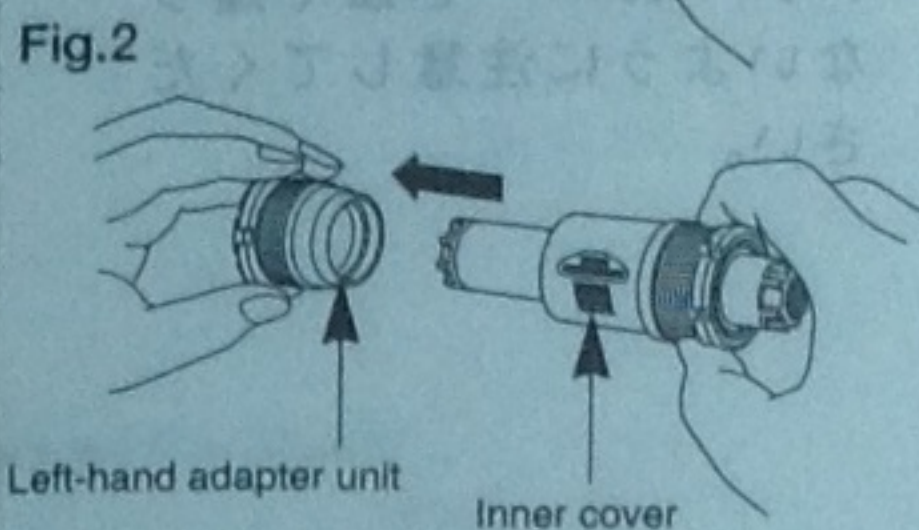
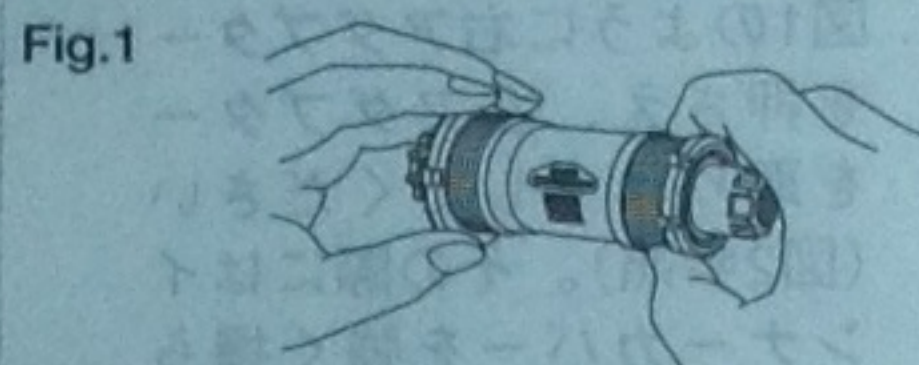

## Installing the bottom bracket

1. Insert the bottom bracket into the hanger.

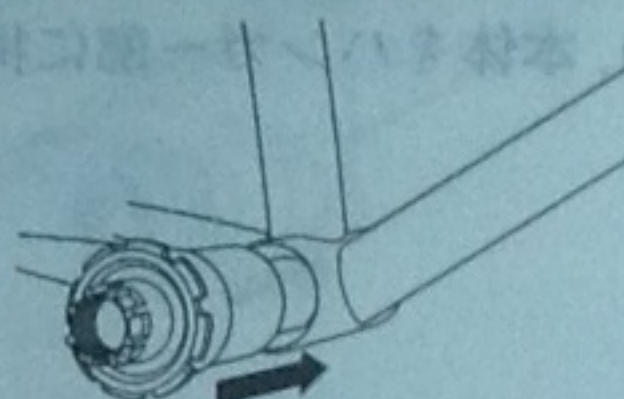

2. Tighten the right-hand adapter by turning it counterclockwise using the special tool (TL-UN96).

Tightening torque:  
50 - 70 Nm {435 - 608 in. lbs.}

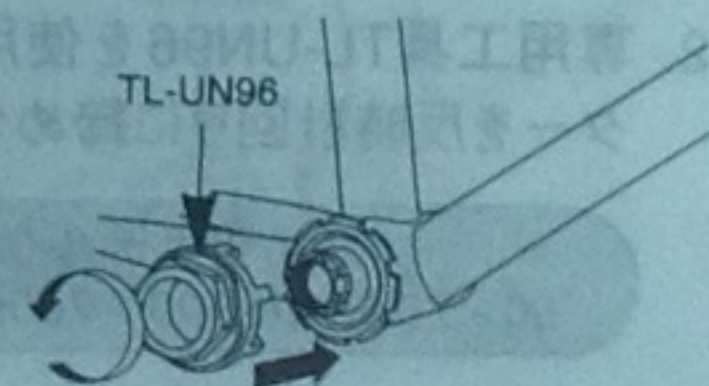

3. Use the special tool (TL-UN96) to tighten the left-hand adapter by turning it clockwise until the spindle turning effort increases sharply. After tightening the left-hand adapter, loosen it by about 1/16 to 1/8 of a turn so that the spindle rotates smoothly.

Tightening torque:  
50 - 70 Nm {435 - 608 in. lbs.}

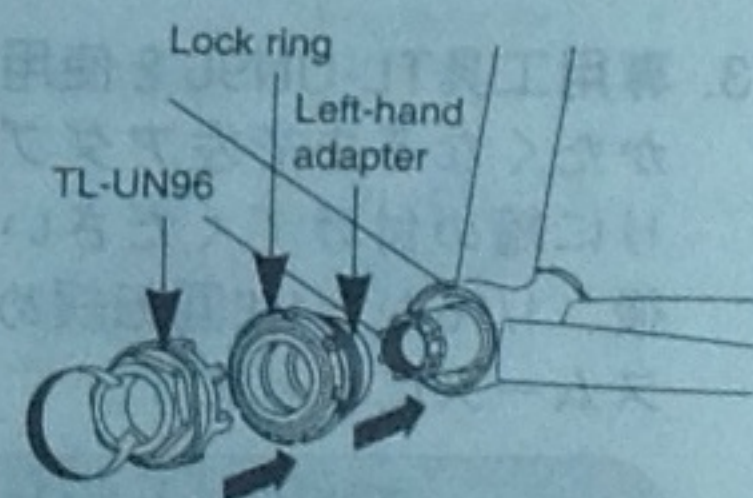

4. Tighten the lock ring while using the special tools (TL-UN96 and TL-FC30) to push in the left-hand adapter.

Tightening torque:  
50 - 70 Nm {435 - 608 in. lbs.}

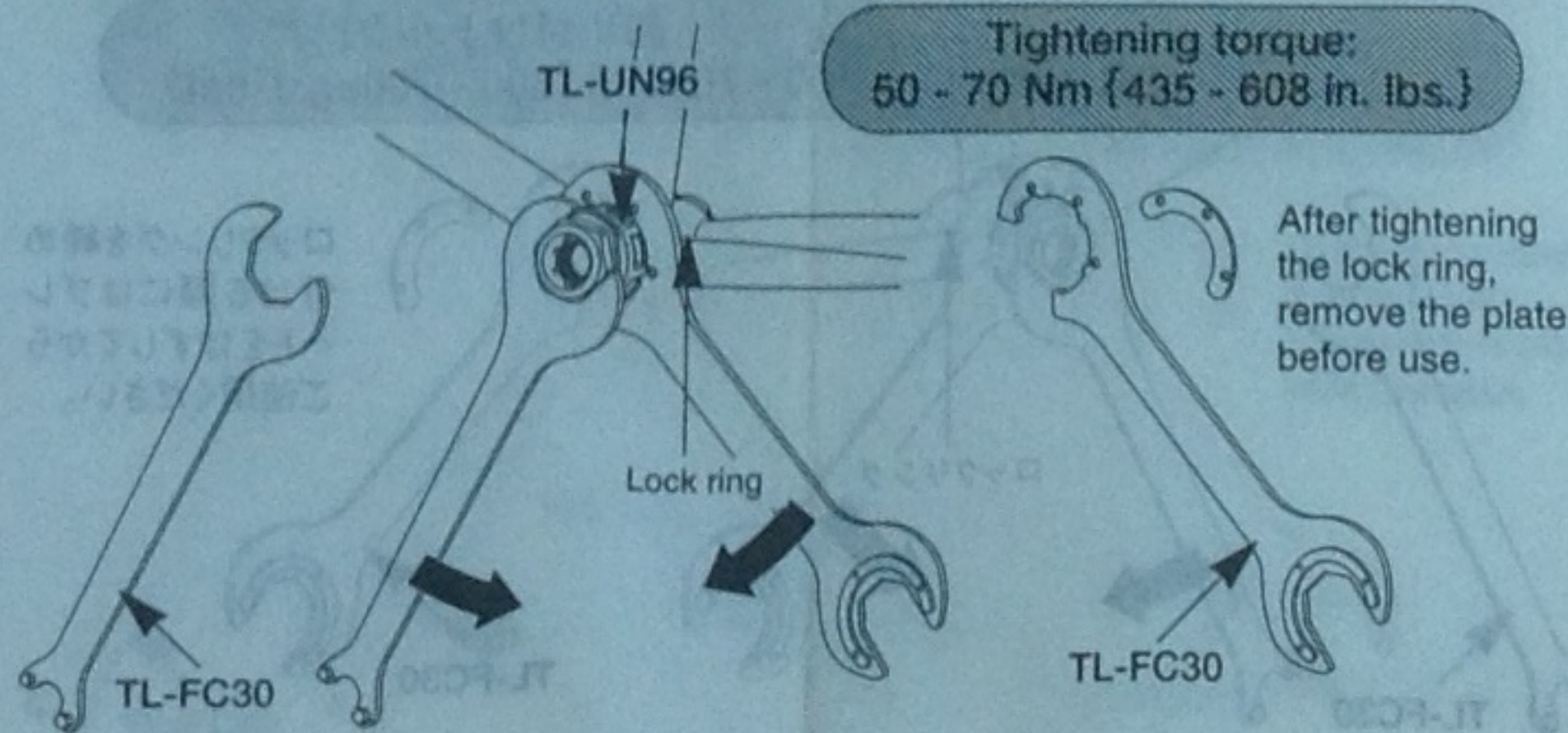

5. Apply grease to the seal guards and then attach the seal guards to the spindle, while making sure that the grooves of the seal rings face inward. If the grooves face outward after the seal rings are installed, the water-tightness will drop significantly. (The seal guards are pushed into the proper positions when the crank arms are installed, so do not force the seal rings on when installing them.)

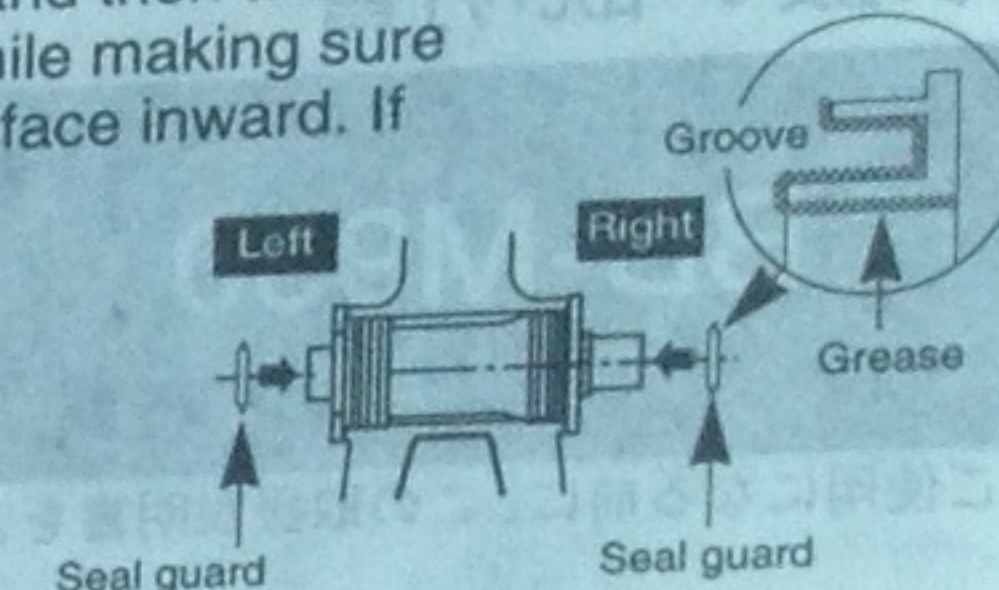

6. Install the right-hand crank arm, and then check that there is no play in the bearing cone is adjusted correctly. If there is some play in the bearing cone, loosen the lock ring and then tighten the left-hand adapter by as little as possible. Repeat steps 4 and 6 until there is no more play.

### ● If using the FD-M950-E (a special frame with mounting bosses is required)

1. Pass the bottom bracket through the bracket hole, and then provisionally secure it to the frame.
2. Secure the front derailleur to the special boss using an M5x0.8 bolt.

Tightening torque:  
4 - 5 Nm {34 - 44 in. lbs.}

3. Use the special tool (TL-UN96) to tighten the bottom bracket.
4. Use the special tools (TL-UN96 and TL-FC30) to install the adapter and the lock ring.

Tightening torque:  
50 - 70 Nm {435 - 608 in. lbs.}

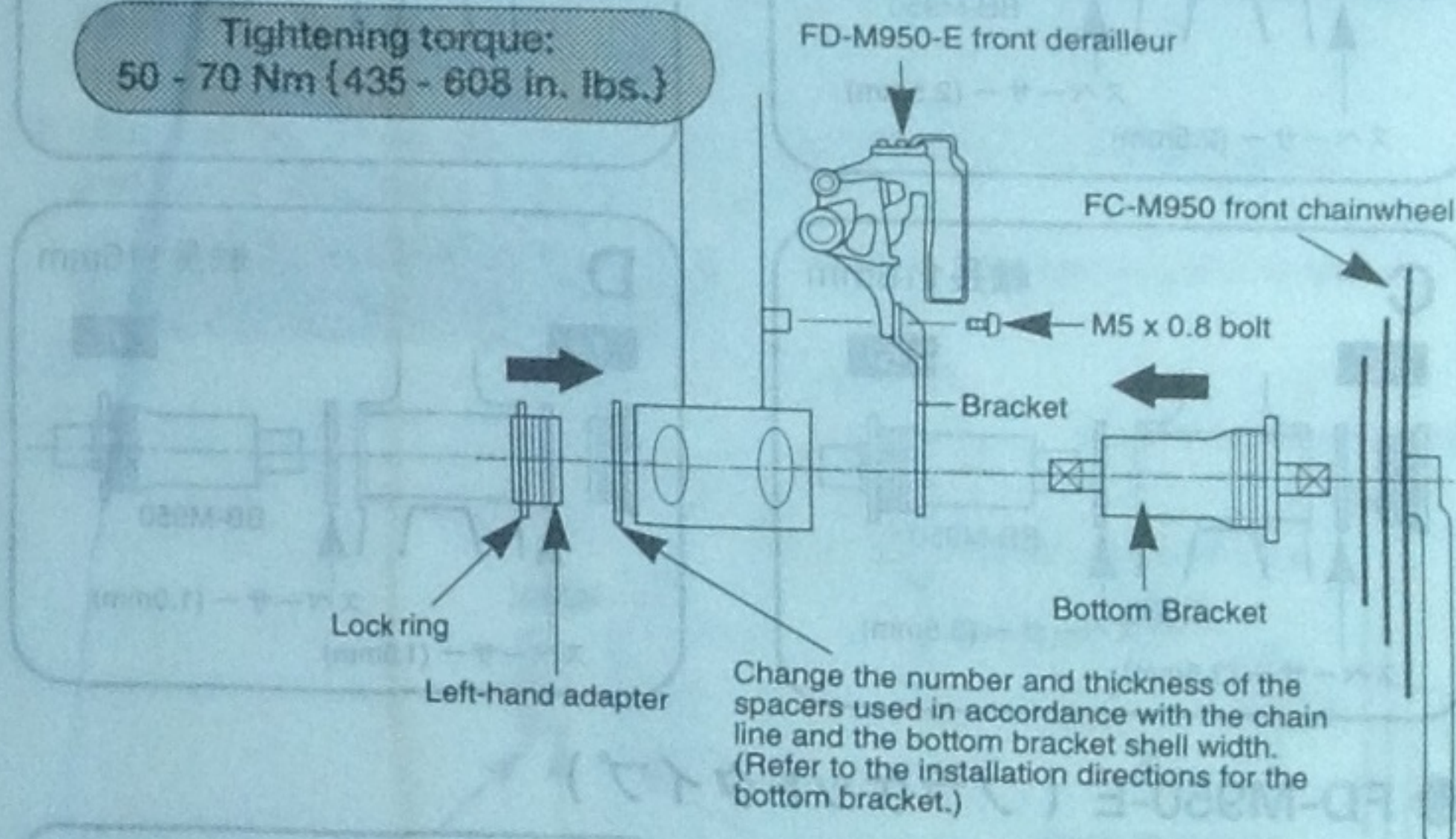

# SHIMANO®

SHIMANO AMERICAN CORPORATION

One Shimano Drive P.O. Box 19815 Irvine California U.S.A. 92713-9615 Phone 714-951-5003

SHIMANO EUROPA

Industrieweg 24 NL-8071 CT Nunspeet Holland Phone 31-3412-72222

SHIMANO INC.

77 Oimatsu-cho 3-cho Sakai Osaka 590-77 Japan Phone 0722-23-3243

©Sep. 1996 by Shimano Inc. XBC SZK Printed in Japan.

These service instructions are printed on recycled paper and can be recycled again

