



S R A M
Corporation





IT WILL
CHANGE
YOUR
MIND

BOB PRIEST

HENK SCHIRNER



TABLE OF CONTENTS

Page 1 ESP Derailleur System

Page 2 ESP 900

Page 3 800 X-RAY

Page 4 SRT 600

Page 5 SRT 450

Page 6 SRT 400

Page 7 SRT 300

Page 8 MRX 400

Page 9 Quikshift

Page 10 After Market Program

Page 11 Jonnisnot

Page 12 Bassworm

Page 13 Grips

Page 14 SRAM SS Cables

Page 15 Tech Service/S.W.A.T.

Page 16 Distributors





ESP Derailleur System



After 8 years of developing high performance shifters for other people's derailleurs, we're pleased to introduce the ESP Derailleur System, the most powerful rear derailleur in the industry. The ESP Derailleur Systems' lightning fast performance was engineered by combining low friction/optimized actuation ratio geometry with powerful springs. Its ultra-light and strong body is constructed from carbon fiber composite and aluminum. Powerful, completely serviceable and simple, the ESP derailleur sets the new benchmark in mountain bike racing performance.

Made in the U.S.A., this derailleur encompasses the "Simply Superior" philosophy upon which all of our products are manufactured.

- Optimized actuation geometry
- Ultralight 185 grams
- Steeper slant for optimal chain gap
- Snap response, high spring force
- Sealed cartridge bearing pulleys
- Beefy seals with wide stress dispersing pivots
- No fault cable clamp
- Fully serviceable





New for 1996! The ESP 900 is designed specifically for use with the SRAM ESP Derailleur System. The ultra-light ESP 900 is loaded with features like dual seals, super-tough smoked housing body, and no-slip granite grip covers. Fastest front and rear shifting in every condition ... for only one purpose: Racing!

- ESP Derailleur Systems designed
 - New indexing cable adjuster
 - 24 speeds
 - 125 grams per set
 - Dual Seals
- FFS (Fastest Front Shifting)—3 rings in a twist
- Stainless Steel 1.1mm ultra-flex cable
 - Stainless steel springs
 - Smoked housing
 - New no-slip grip cover

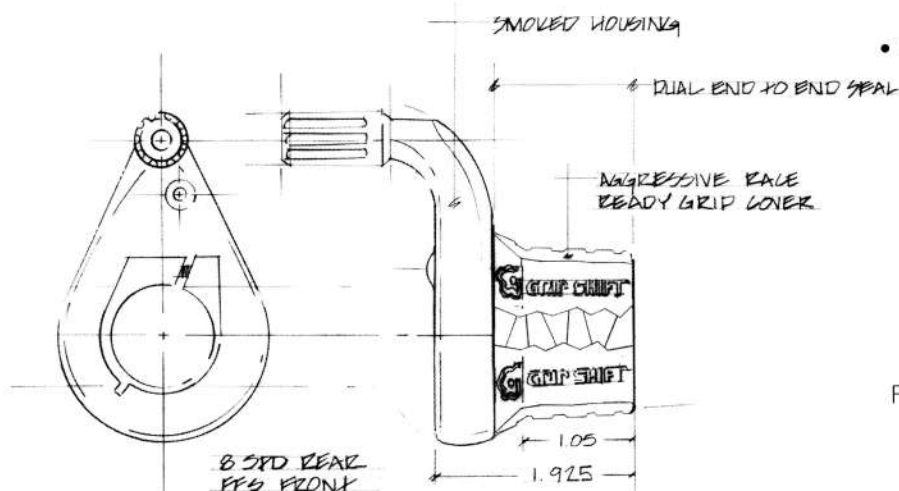

This Shifter System comes complete with FFS Friction Front Shifter, GSR Racing grips, Jonnisnot grease packet, washers, service instructions, & race stickers.

800 X-RAY



The World Championship X-RAY is back for 1996. This year we've added the 'diamond cut' grip covers, dual seals and the new super tough smoked body. The 800 X-RAY, championship proven as the leader in high-end shifting components. The winner has returned!

- 24 speeds
- FFS (Fastest Front Shifting)—3 rings in a twist.
- 125 grams per set
- New Dual Seals
- New super tough smoked body
- New indexing cable adjuster
- Stainless steel springs
- Stainless steel 1.1mm ultra-flex cable
- New 'diamond cut' grip cover

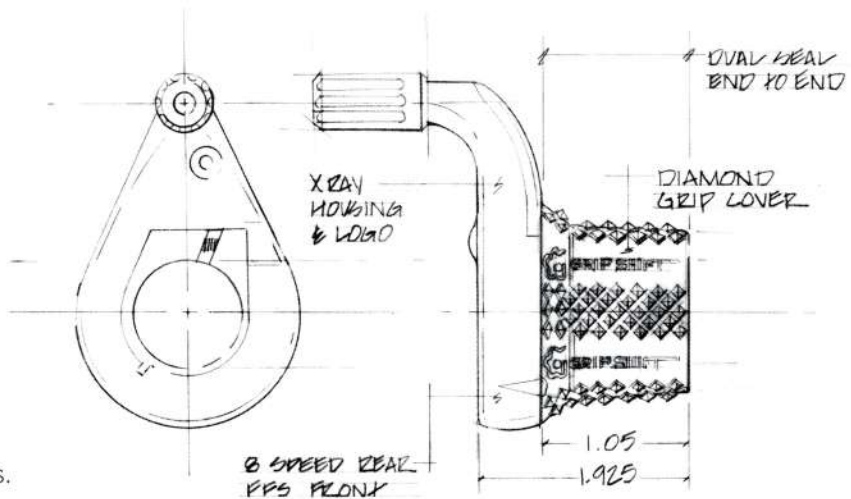

This Shifter System comes complete with FFS Friction Front Shifter, GSR Racing grips, Jonnisnot grease packet, washers, service instructions, & race stickers.



The SRT 600 gets supercharged for 1996 with stainless steel 1.1mm ultra-flex cable and new shifter covers. Available in 21 and 24 speeds. The SRT 600 is lightweight and offers superb performance at a great value.

- 24 or 21 speeds
- 135 grams per set
- FFS (Fastest Front Shifting)—3 rings in a twist
 - Stainless steel springs
- Stainless steel 1.1mm ultra-flex cable
 - Sealed system
- BIG number gear indication
 - Stealth matte black design
 - New indexing cable adjuster

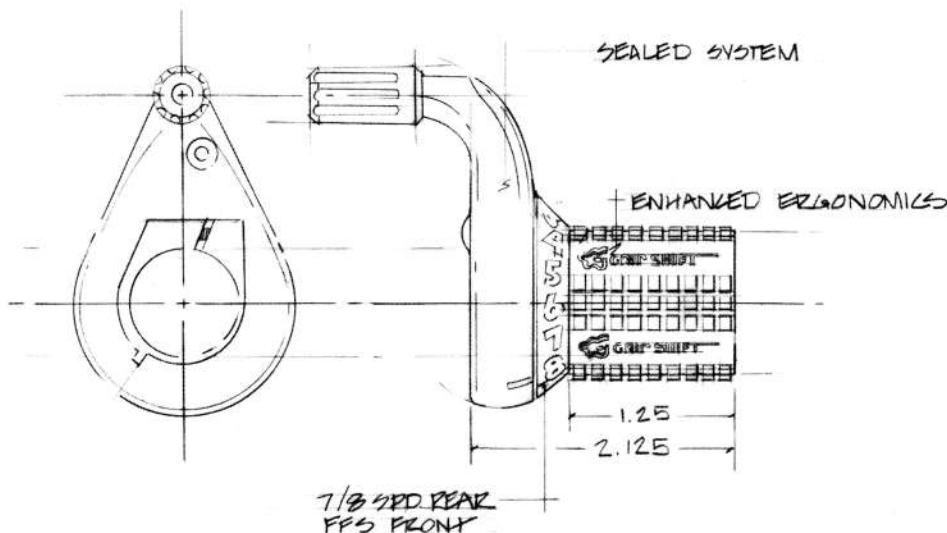

This Shifter System comes complete with FFS Friction Front Shifter, GSR Racing grips, Jonnisnot grease packet, washers, service instructions, & race stickers.

SRT 450



New for 1996! The SRT 450; an elegant integration of function and simplicity. Cold forged aluminum, 2.5 finger lever coupled with FFS and stainless steel spring technology. Combined to form an ultra-light and logical control center. Intuitive, simple, precise.

- 21 speeds
- 150 grams per shifter
- FFS technology (Fastest Front Shifting)—3 rings in a twist
- Stainless steel springs
- BIG number gear indication
- Treacherous path seal
- Die drawn 1.2mm cable
- Cold forged Aluminum lever—return spring & reach adjuster
- Brake cable adjuster
- Stealth matte black design
- Simple, reliable & serviceable



This Shifter System comes complete with FFS Friction Front Shifter, MTB stationary grips, Jonnisnot grease packet, washers and service instructions.

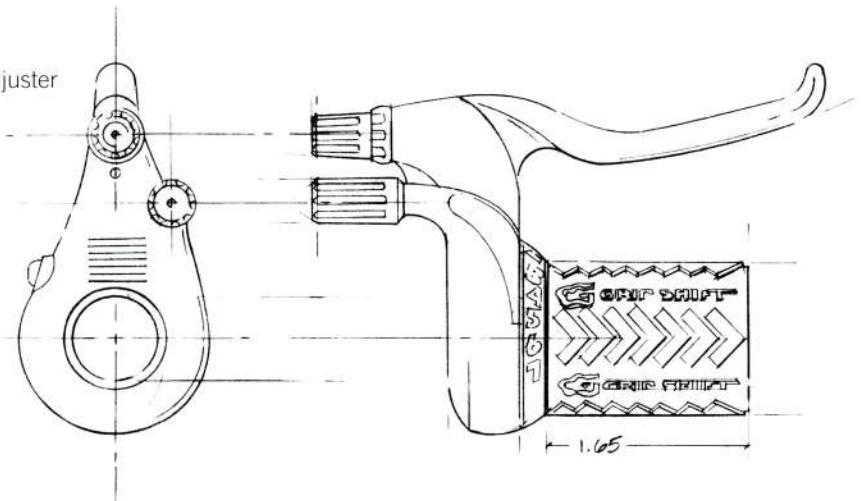



The 1996 SRT 400 is a brilliant combination of light weight construction, aggressive styling and high performance shifting. Featuring the new MTB grip covers, FFS and stainless steel spring technology, the SRT 400 is race ready.

- 21 speeds
- 140 grams per set
- FFS technology (Fastest Front Shifting)—3 rings in a twist
 - Stainless Steel springs
 - Die drawn 1.2mm cable
 - MTB grip covers
- Stealth matte black design
- BIG number gear indication

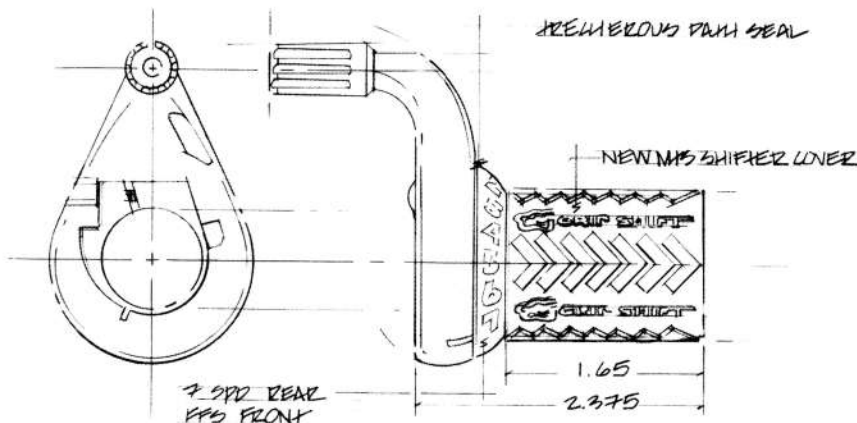

This Shifter System comes complete with FFS Friction Front Shifter, MTB stationary grips, Jonnisnot grease packet, washers and service instructions.



SRAM's classic shifter returns for '96 featuring new metal spring technology, enhanced ergonomics and BIG number gear indication. For MTB's, trekking, commuter, or cross, the SRT 300i is the perfect choice for every rider. Jump on and give it a TWIST!

- Stainless steel springs
- Treacherous path seal
- Smooth die drawn 1.2mm cable
- BIG number gear indication
- 155 grams per set
- Textured matte black housing

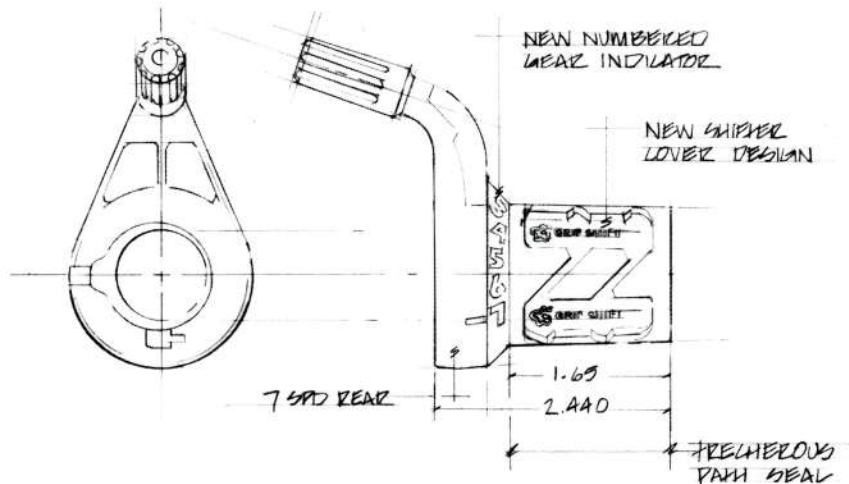



A redesigned shifter cover and stationary grip make the MRX more ergonomic and friendly for the entry-level mountain bike, cross, and juvenile rider. SIMPLE, INTUITIVE and super light action. Advanced technology, at the right price—MRX 100!

- 21 speeds
- Stainless steel springs
- BIG number gear indication
- Smooth die drawn 1.2mm cable

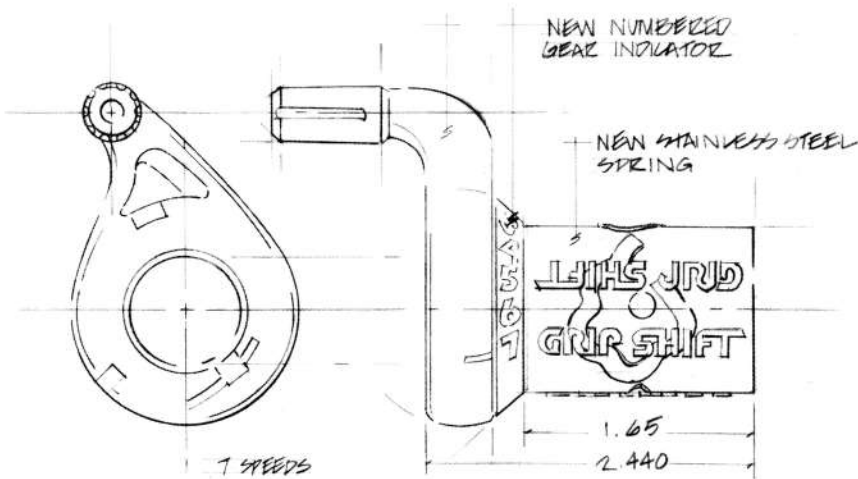

This Shifter System comes complete with friction front shifter, MTB stationary grips, Jonnisnot grease packet, washers and service instructions.



The 1996 Quick Shift™ offers SIMPLE, super-light action shifting to the entry level rider. It features the purest and simplest Grip Shift characteristics...we've made shifting gears fun and intuitive. Celebrate Simplicity—Quick Shift.

- 18 & 15 speeds
- Stainless steel springs
- BIG number gear indication
- Standard 1.2mm cable

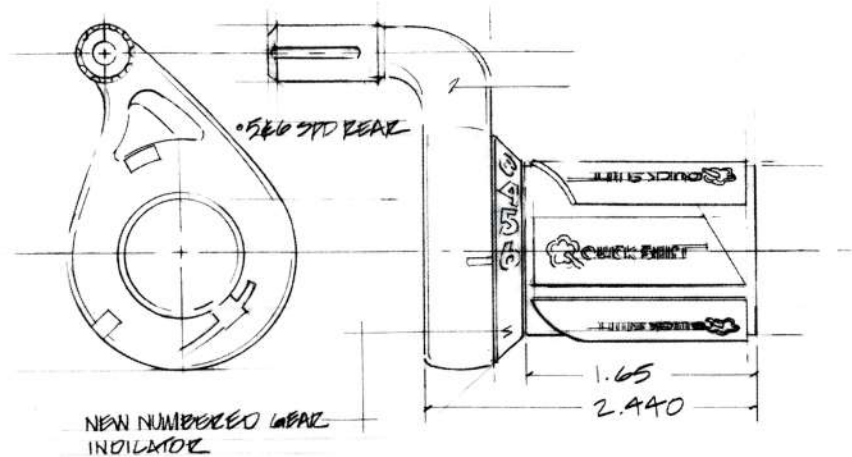

This Shifter System comes complete with friction front shifter, MTB stationary grips, Jonnisnot grease packet, washers and service instructions.



Aftermarket Program

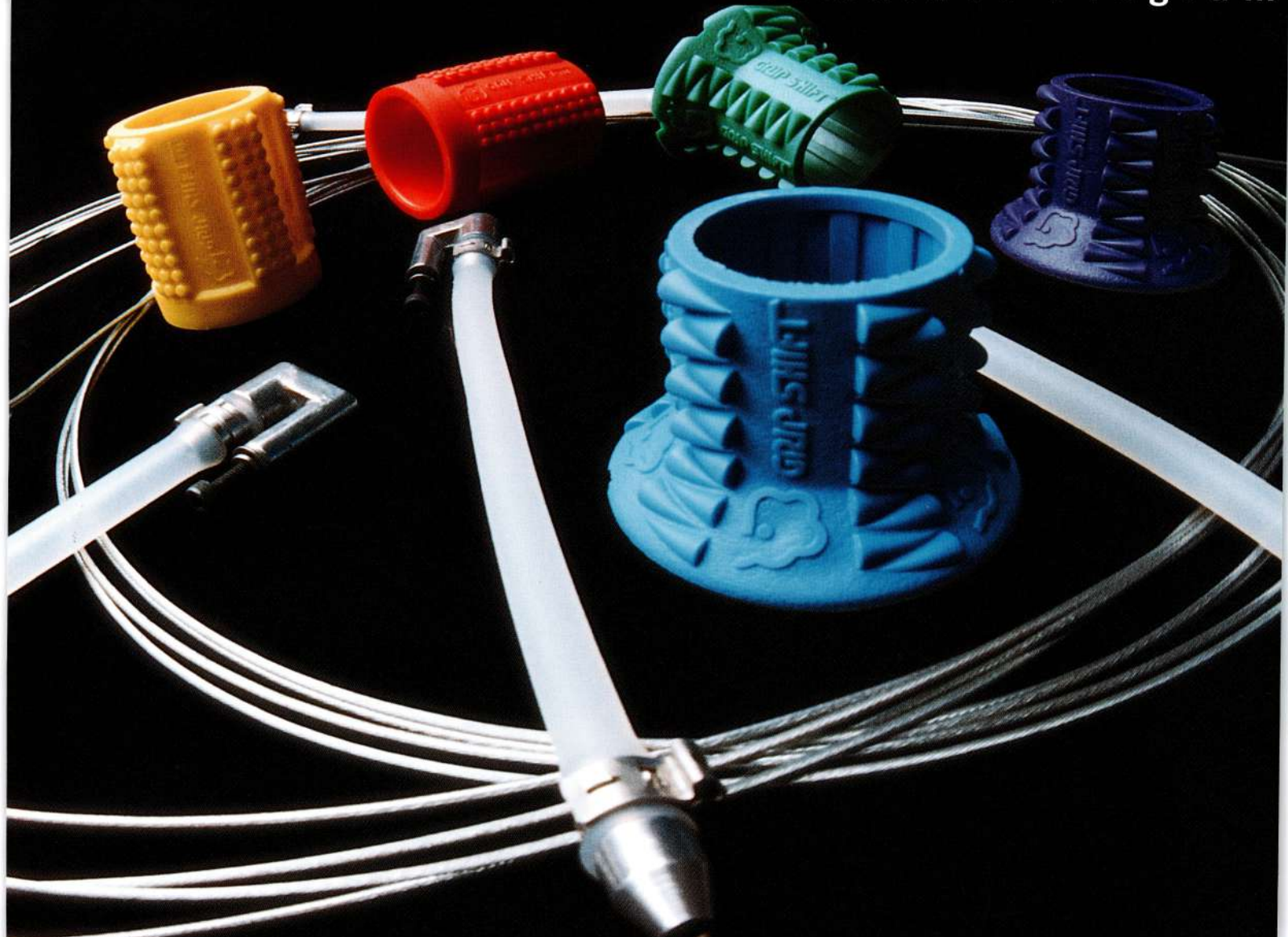

SRAM AFTERMARKET PROGRAM

Welcome to the 1996 SRAM Corporation Aftermarket Program. As you see from the name, we are no longer just Grip Shift. We are a company that manufactures a vast array of products. The most notable addition to our '96 product line is the ESP Derailleur System, shown on pages one and two of this catalog. The following pages will introduce you to the various products we manufacture. All of our products are manufactured to the highest quality standards and designed to be intuitive, technologically superior, and to enhance your mountain biking experience.

Jonnisnot Lubricant, SRAM SS Cables, Mud Shark & Sharktooth Grip Covers, and the Bassworm Seal were developed by some of the best minds and bodies in the cycling industry. There are no substitutes for our grease, cables, and specialized grip covers. Designed for function—with a little pizzazz.

When you buy and use our shifters, derailleurs, and any of the other SRAM products, you will feel the unique advancements they make to your bicycle's performance and your off-road riding experience. You will have the comfortable feeling of owning time tested products and enjoy knowing that you will be able to maintain or upgrade your SRAM products with ease. Celebrate the Simplicity.

SRAM's Aftermarket Program has always kept the dealer and consumer at the highest level of satisfaction. You are important! One example of our quest to satisfy our customers is SRAM's small parts & individual shifter program. We have developed a program that allows customers to buy a complete shifter kit, or purchase individual shifters; and further, small parts are available. A goal of our engineering department is to develop the best technology and optimize every piece of a component. This translates into intuitive products that are completely and easily serviceable.



Jonnisnot™



Jonnisnot™

"Just the name tells you it's no ordinary bike grease!" This factory lubricant is the lifeblood of all Grip Shift™ shifters. Jonnisnot™ is specifically formulated for the high performance plastic on plastic, and plastic to metal interfaces that exist in our shifters. Because of its unique make-up, in comparison to ordinary lubricants, Jonnisnot does not bloat or soften plastics (which results in sluggish performance). Additionally, it resists dissipation due to its heavy viscosity. Jonnisnot is the 'must use' grease in all Grip Shift shifters: any other substituted lubricants should clearly read 'Grip Shift Approved'. Believe us, all this technical jargon is for real...lube 'em with Jonnisnot!

- Jonnisnot is available at your local bicycle store in this very stylish 2 ounce syringe. To maintain optimum shifter performance, use it or lose it!

Bassworm™



Bassworm™

By sealing the rear section of cable housing and cable connected to the rear derailleur from elemental contamination, the Bassworm seal prolongs the efficient cable travel necessary for precise index shifting. Due to the materials used in the construction of the Bassworm's elastic body, a sense of sprint or preload is achieved. This effectively boosts rear derailleur response to shifter commands, creating a precise and fast shift.



Grips



Mud Shark™

GSR

Sharktooth™

Mudpaw™

Mud Shark™

Get the ultimate grip on our performance 800 X-RAY and ESP 900 shifters. Designed for the most extreme riding conditions, the Mud Shark's raised rows of 'teeth' take bite and insure no-slip contact. Slip'em on and rage!

Sharktooth™

An all condition replacement grip cover for the 800 X-RAY and ESP 900 shifters. Sharp, tactile, and ready when you are. Seven great colors.

Mudpaw™

Update your SRT 500R and SRT 600 with the original factory designed racing grip covers. Rows of aggressive nubs act like paddles in wet or muddy riding conditions. Available in red, yellow, blue, and black.

GSR RACING GRIPS...these are the ones that don't twist!! Providing the ultimate in comfort and feel, the sensational GSR stationary grips offer the perfect fit with your ESP 900, X-RAYs, or SRT 600 shifters. Designed to offer excellent transition between shifter and grip...the GSR is pure pleasure!





SRAM SS Cables
As much as Jonnisnot grease is the 'lifeblood' of Grip Shift shifting performance, the quality of the linkage between shifter and drivetrain is essential. Quality indexing relies on low friction and an unrestricted cable system.

In 1995 we began offering a technologically superior cable with our SRT 800 X-RAY that exhibited some of the finest characteristics for setting up and maintaining quality index shifting. High flexibility, corrosion resistance and smooth surfacing are the properties that separate the SRAM SS Cables (stainless-steel 1.1mm diameter) from any other cable on the market. We are now pleased to offer these superior cables as an accessory product. Packaged both in pairs and in bulk.





Tech Service/S.W.A.T.

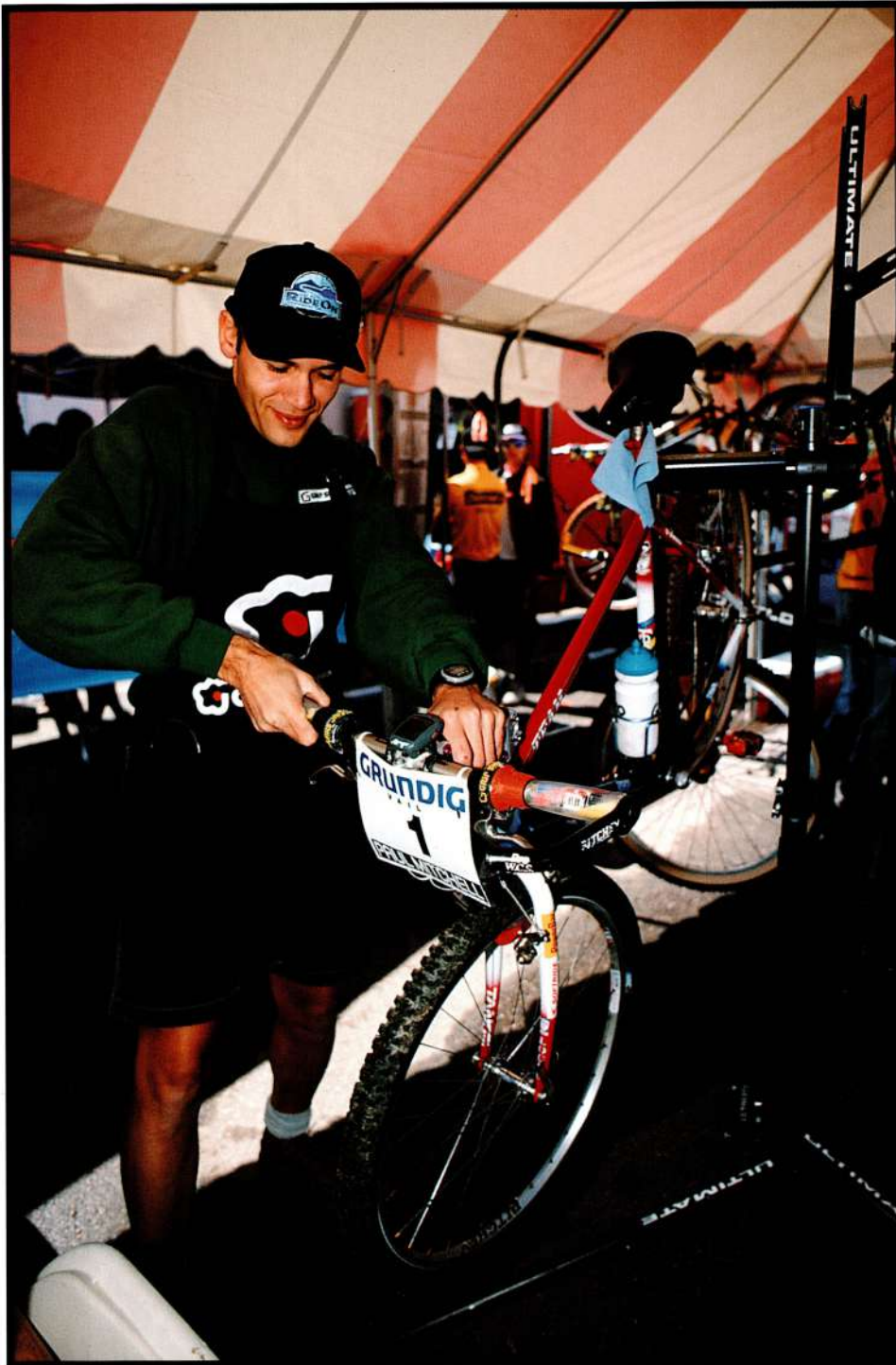

SWAT TEAM

The SRAM S.W.A.T. Team (Service Warranty And Technical), commissioned in 1992 is an international technical customer service program consisting of a group of professional drivetrain, retail and racing mechanics. Their role in the retail market place is to provide product support, drivetrain education, and gather immediate trend information on SRAM products and services at the professional bicycle dealer level. Each member is native to their market and participates in single and regional bicycle dealer seminars, regional and international racing venues, as well as factory and OEM support.

To date, SRAM operates two Mountain Bike Racing Technical Support Vehicles to provide mobile technical support to a variety of events, highlighted by North American and European U.C.I. and N.O.R.B.A. mountain bike races.

In addition to our 'road team', S.W.A.T. representatives maintain our in-house dealer and consumer technical support 'Hotlines'. These hotlines are located in our Chicago, Netherlands, and Taiwan facilities.

Distributors

NORTH AMERICAN DISTRIBUTORS

Cycletech Canada Ltd.
#123, 3016-10th Ave. NE
Calgary, Alberta T2A 6A3

Downeast Bicycle Specialists
P.O. Box 226
Fryeburg, ME 04037

The Hawley Co.
439 Burton Rd.
Lexington, SC 29072

The Merry Sales Co.
1415 San Mateo, Ave.
San Francisco, CA 94080

Norco Products Ltd.
7950 Enterprise St.
Burnaby, British Columbia
V5A 1V7

Ponce Bicycle Supply
165 Villa St.
Ponce, Puerto Rico 00731

Quality Bicycle Products
9201 Penn Ave. South, #40
Bloomington, MN 55431

Quantum Bicycle & Fitness
26 W. 515 St. Charles Rd., Unit B
Carol Stream, IL 60188

Quentin Distributors
845 Carol Ct.
Carol Stream, IL 60188

Raleigh USA
22710 72nd Ave. South
Kent, WA 98032

Richard Browne & Co.
3962 Chesswood Dr.
Noth York, Ontario M3J 2W6

Schwinn Cycling & Fitness
1690 38th St.
Boulder, Co 80301

Security Bicycle Accessories
32 Intersection Street
Hempstead, NY 11551

Service Cycle Supply
48 Mall Dr.
Commack, NY 11725

Seattle Bike Supply
SBS-Kent, 7620 South 192nd St.
Kent, WA 98032

Specialized Bicycle Components
15130 Concord Circle
Morgan Hill, CA 95037

Trek Bicycle Corporation
N 57 W. 39605 HWY 16
Oconomowoc, WI 53066

United Bicycle Parts
691 Washington St.
Ashland, OR 97520

Western States Imports
4030 Via Pescador
Camarillo, CA 93010

MEXICO

Benotto
Calzada De Tlalpan, No. 744
03150 Mexico

PANAMA

Distribuidora Rali, S.A.
Apartado 87-0852
Panama 7 Panama

ARGENTINA

Broni S.A.
Juan J. Paso 1260
(1832) Lomas de Zamora
Buenos Aires, Argentina

JAPAN

Kawashima Cycle Supply
No. 4-2-4 Kushiya-Cho
Higashi, Sakai
Osaka, Japan

Nishinao Shokai
6-16-8 Sotokanda Chiyodaku
Tokyo 101, Japan

SOUTH AFRICA

Adventure Sports Trading
P.O. Box 1748
Port Elizabeth, South Africa
6056

Bike Center
Puccini Str.
P.O. Box 23802
Windhoek, South Africa

AUSTRALIA

Sports Plus
10 Elizabeth St.
Paddineton NSW 2021
Australia

NEW ZEALAND

Cycle Supplies (NZ)
33051 Christchurch
New Zealand

SINGAPORE

Alpera International
9 Jalan Layang Layang
Singapore 2159

EUROPEAN DISTRIBUTION

Please Contact:

SRAM Europe
Lansinkesweg 4/218
7553 AE Hengelo OV
Netherlands

Ph: 31-74-500-780
Fx: 31-74-500-710

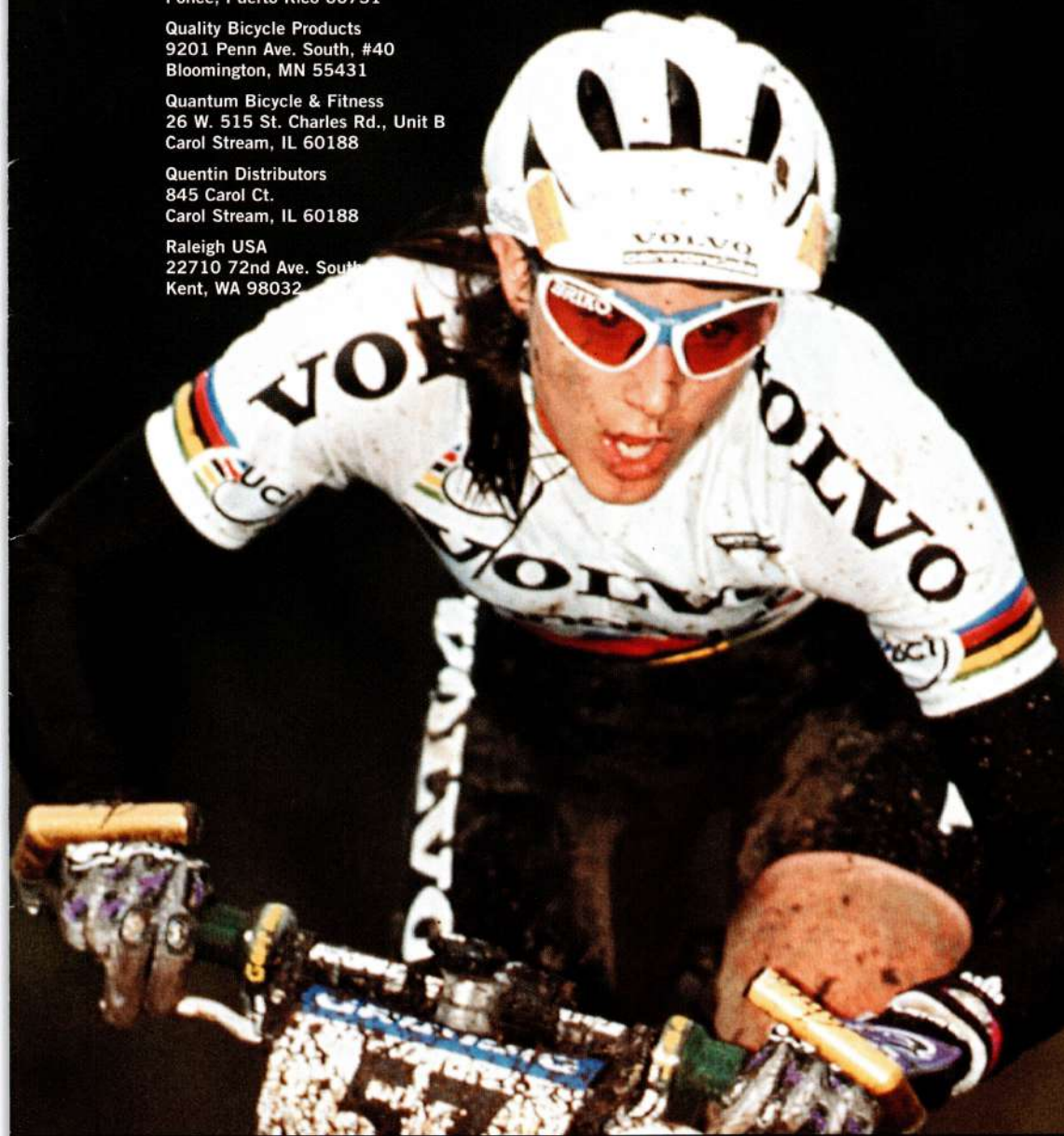

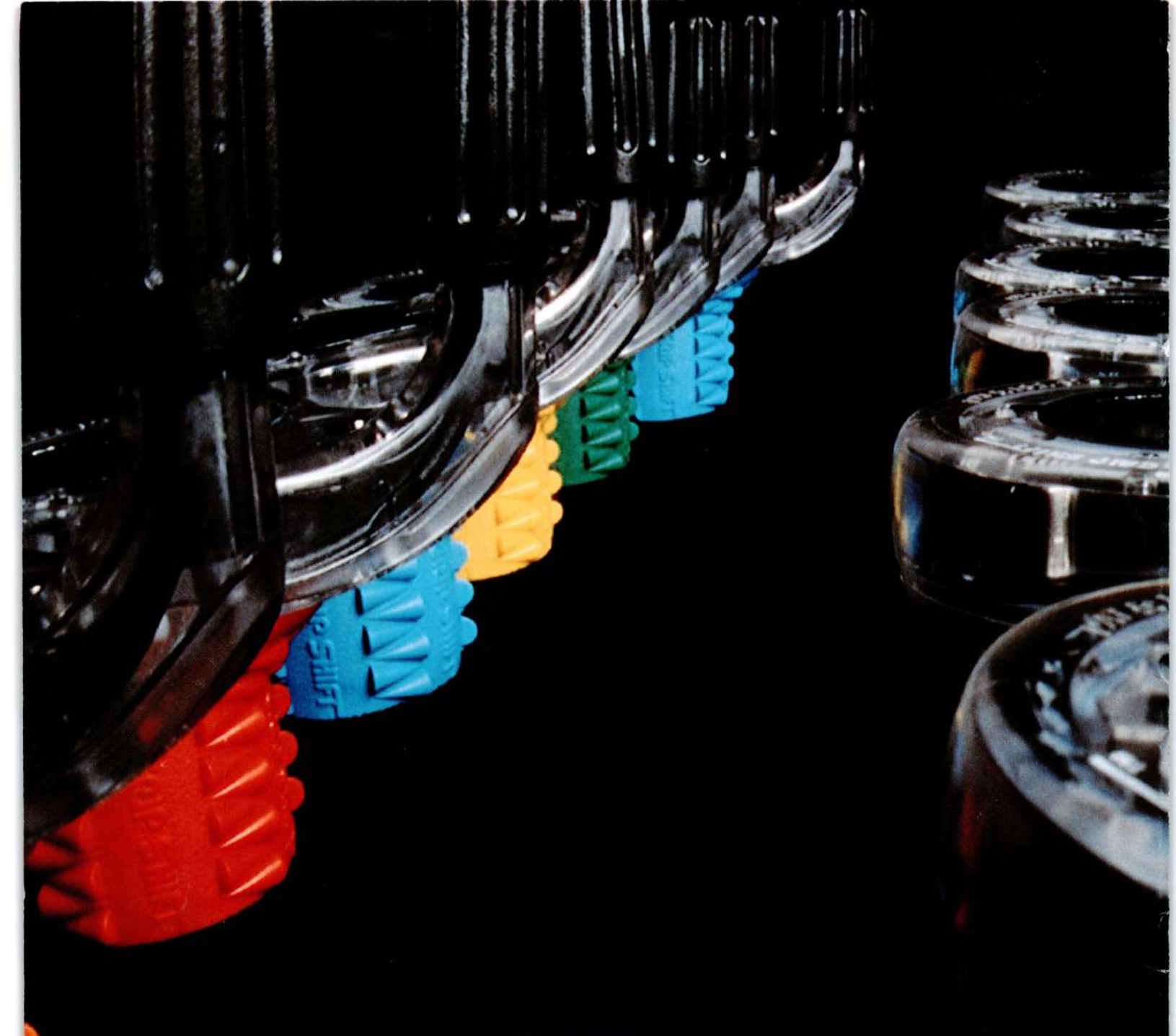

Chicago, Illinois U.S.A
Netherlands • Ireland • Taiwan • China