





# Y

eti Cycles, Inc. was born in the fall of 1985, when John Parker sold "Beulah Mae," a 1928 Indian motorcycle, for a frame fixture and an armful of chromoly tubing. This fateful turn of



events came after crashing a midget race car and suffering serious injuries. John and wife Linda, were forced to make a transition from the Special Effects world of the Hollywood Studios to the humble beginnings of Yeti Cycles.

While Linda was making ends meet as an elementary school teacher, John was dreaming up the future of the latest arrival to the budding mountain bike industry. He promptly began putting the Yeti wheels in motion in the back of Matt Sweeney's Special Effects Shop.

Things began to move quickly in the fast-paced mountain bike circuits of Southern California. John welcomed partners Chris Herting and Frank "FTW" Wadelton to assist in the fabrication of what were rapidly



becoming known as some of the highest quality, most innovative racing frames available to the growing MTB market. Shortly after Matt Sweeney kicked Parker and Yeti out of his shop, a small facility in Agoura Hills, CA was producing hundreds of "Handmade in the

USA," chromoly and Easton aluminum framesets. After winning two gold medals at the inaugural 1990 UCI World Mountain Bike Championships, we decided to relocate our entire operation and staff of twelve to the self-proclaimed Mountain Bike Mecca of the World: Durango, Colorado, U.S.A.

Once settled in our new, 10,000-square-foot digs, Yeti set about the task of increasing the production of our race-winning, chromoly and aluminum hardtail frames. With one of the finest testing grounds in the universe right in our own backyard, Yeti designed two of the best performing full-suspension frames in the business. As the Yeti name became better and better known, we further developed an extensive line of accessories and softgoods that are now in high demand around the globe.



We are extremely pleased to present our 1996 anniversary catalog in celebration of our ten successful years in the bicycle business. We would like to heartily thank all of you for supporting our efforts. Also, a special thanks to our families, friends, racers and those, too numerous to mention, who have helped us along the way. We look forward to a bright future, continued innovation and the opportunity to remain a part of your lives.

Brett Hahn - General Manager

YETI CYCLES...faster by design

1985



Team Yeti: Russell "The Muscle" Worley, Greg Drees and Aaron "Drew Blood" Cox.



The original "Yeti Man" created by Craig Stearnon of Blue Comet Comics.

1986



Yeti's first catalog with Kye Sharp coming in for a landing at the '86 NORBA National in Durango.

Russell "The Muscle" on his way to a top x-country finish.



Factory rider Greg "Stress" Drees gets some stylish air while off the front in Durango.

1987



The "Yeti Man" begins the transformation.

No dabs allowed here, Factory trials rider: Aaron Faust.







Happy Birthday, Yeti!!! Yeti Cycles has always been known for cutting-edge technology that is consistently proven on race courses and secret singletracks around the world. Nothing is changing now. To commemorate

our tenth anniversary, we decided to take our experience and expertise with Easton aluminum and meld it into a bold statement of our affection for the classic cruiser. The Zephyr is not simply an exercise in nostalgia, but a unique blend of modern-day technology and classic styling that clearly says, "We know how to have a good time!" Forget the envy of your pals, you're going to be busy explaining to the family why you keep it in the bedroom. "And NO, Son, you can't borrow the Zephyr tonight!"

Classic, double-curved top tubes form a swoopy, uninterrupted line from the headtube to the semi-sloping dropouts.

Just like our purebred race bikes, there's no straight-gauge 6061 here; nothing but the finest Easton 7005 ProGram UarLite throughout.

Limited production, 10th Anniversary, vintage brass headtube badge.



	18"
A	23.0"
B	71°
C	73°
D	42.0"
E	17.25"
F	11.5"
G	1.5"
H	6.0"

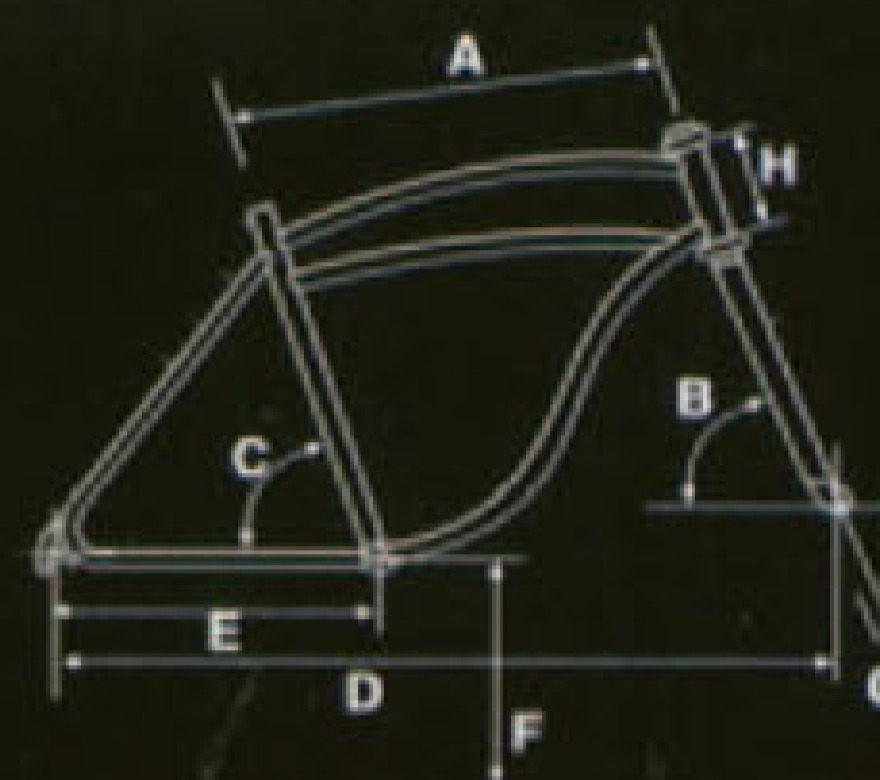

Seatpost Diameter: 26.8mm - Headset Diameter: 1.25"  
 Bottom Bracket Width: 73mm; English Standard Threading  
 Shimano Inter 7 compatible (130mm rear axle spacing)

# YETI ZEPHYR



The "Yeti Tribe" at its first photo shoot in the Santa Monica Mountains.



The early days with just a few co-sponsors. Jersey designed by close friend Chris Franz.



J.P. with a young Johnny "T" and the Godlike Charlie Linky.

1988



John Parker and Russell "The Muscle" Worley following the Desert-to-the-Sea 150 mile epic.

Our colossal, three-fold, product catalog touting our early accomplishments.



RIDE A RARE BREED!



The original Yeti F.R.O. as tested in MBA, sporting the famous "dart" paint scheme.



# YETI A.R.C.

ALLOY RACING COMPOSITES



If it ain't broke, don't fix it! Yeti's John Parker, Juli Furtado and Easton engineer, Chuck Teixeira, began working on the A.R.C. project in 1990 and released it to the public in 1992. An immediate success, the A.R.C. dominated the racing world by winning more NORBA National, Grundig Cup and UCI World Cup events than any of the competition. Yeti's racing heritage is indisputable, but we also recognize the needs of the hardcore enthusiast in all of our designs. The A.R.C. has been tested by countless publications and has received nothing but rave reviews. "Simply put, the A.R.C. is the best all-around hardtail I've ridden, and that includes my two titanium bikes...the loop stays must work." - September 1995 - BIKE Magazine. A masterful blend of light weight, rigidity and comfort. If you are looking for the light weight of titanium, the rigidity of aluminum and the comfort of steel, look no further; the A.R.C. has it all wrapped up for you in a single package.

Custom Yeti-Specified, Easton 7885 ProGram BariLite tubing with industry-famous Yeti TIG welds throughout.

One-piece, computer-bent unstay with internally and externally tapered walls for superior ride quality and improved chainline.

Oversized down tube, ovalized seat tube and .875 diameter chainstays for exceptional torsional rigidity.

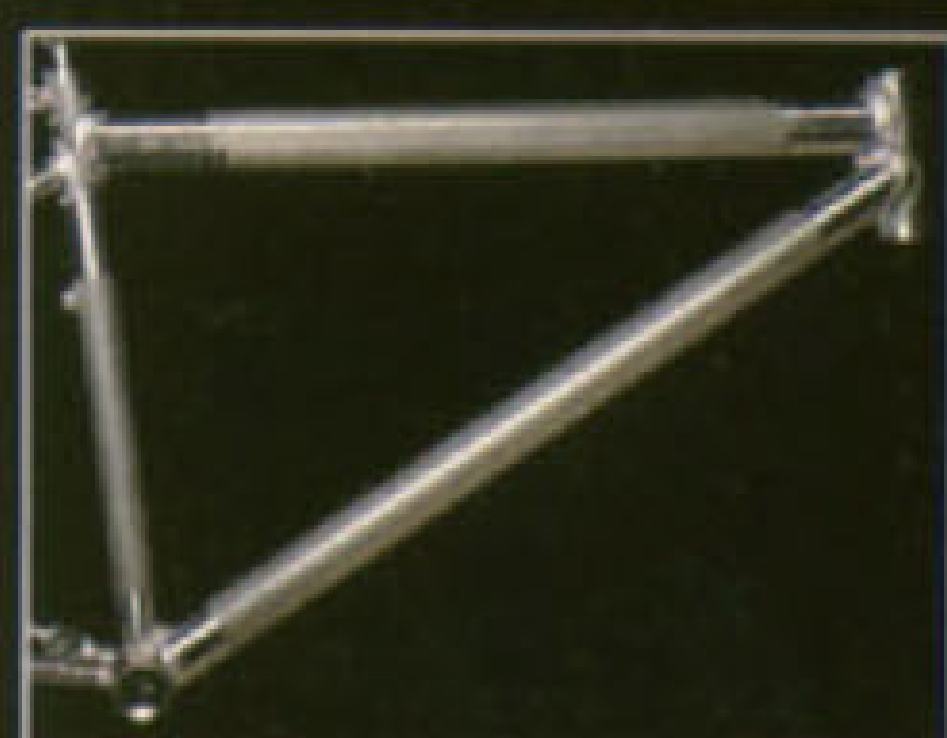

	12"	16"	17.5"	19"	20"
A	20.5"	22.6"	22.8"	23.1"	23.5"
B	71°	71°	71°	71°	71°
C	74°	73°	73°	73°	73°
D	40.5"	41.75"	41.75"	41.9"	42.0"
E	16.75"	16.9"	16.9"	16.9"	16.9"
F	11.0"	11.5"	11.5"	11.5"	11.5"
G	1.5"	1.5"	1.5"	1.5"	1.5"
H	4.0"	4.5"	4.5"	4.5"	6.0"
Stand-over	27.5"	29.25"	29.75"	30.5"	31.75"

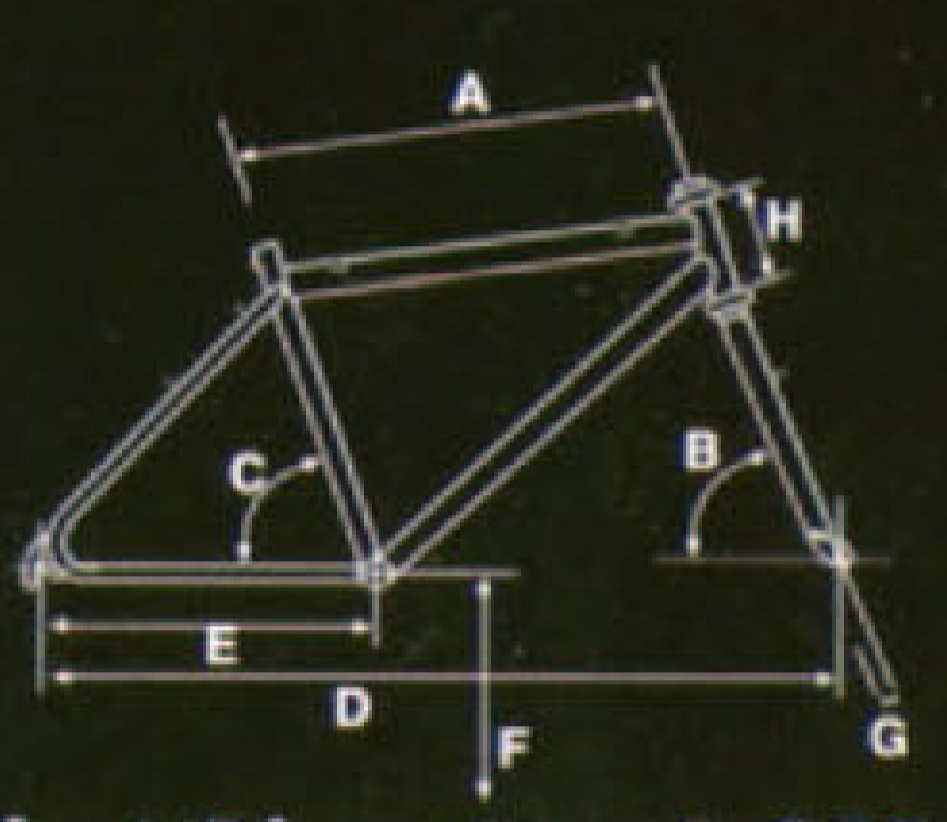

Seatpost Diameter: 26.8mm - Headset Diameter: 1.25"  
 Bottom Bracket Width: 73mm; English Standard Threading  
 Front Derailleur Clamp Diameter: 31.8mm/1.25"



1989



Factory Expert Todd Clark leads out the expert class at the Big Bear National Finals on the cover of our '89 catalog.



"Gathering of the clan" at the Big Bear Finals.



Jody Weisel's wild dream. MBA commissions Yeti to build the "Ultimate" mountain bike. Very RAD, people love it, is Yeti going to build one?!



Dr. Al Farrell, Mountain Bike Philanthropist, John Parker's personal Spiritual Adviser and all-around bitchin' guy!



VIVA YETI!! VIVA ZAPATA!! Zapata Espinoza, Yeti's "Minister of Race Propaganda."

1990



1st full-color catalog designed by Suzi Dotan.





Decisions, decisions. Full-suspension or hardtail, air/oil or elastomer, short travel or long travel? Do you want an engineering degree OR do you just

want to ride your bike...EVERYWHERE!? With its fully active, air/oil damped rear suspension, the A.S. rolls smoothly over the rough stuff and hooks up flawlessly on those marble-strewn, technical climbs. "Stiff and speedy in the flats...sweet downhillin' ecstasy...If there is such a thing as a crash-proof bike, this is the closest I've come."

- August 1994 - Dirt Rag. The neutral pivot points allow you to pedal efficiently in or out of the saddle without any drivetrain-induced pogo or squat. So why worry about making those decisions, when the Yeti A.R.C.-A.S. answers all of the performance questions for you.

Trademark Yeti-Cross cable routing with slotted cable guides throughout makes service a breeze.

Super smooth, user-serviceable, highly wear-resistant, TURCITE pivot bushings at all pivot points. You don't need a portable machine shop to service this rig.

Risse Elroy air/oil shock body with externally adjustable damping.



	16"	17.5"	19"	20"
A	22.6"	22.8"	23.1"	23.5"
B	71°*	71°*	71°*	71°*
C	73°*	73°*	73°*	73°*
D	42.2"	42.2"	42.2"	42.2"
E	17.2"	17.2"	17.2"	17.2"
F	11.5"	11.5"	11.5"	11.5"
G	1.5"	1.5"	1.5"	1.5"
H	4.5"	4.5"	4.5"	6.0"
Stand-over	29.25"	29.75"	30.5"	31.75"

\* depending on set-up

**Seatpost Diameter: 26.8mm - Headset Diameter: 1.25"**  
**Bottom Bracket Width: 73mm; English Standard Threading**  
**Front Derailleur Clamp Diameter: 31.8mm/1.25"**

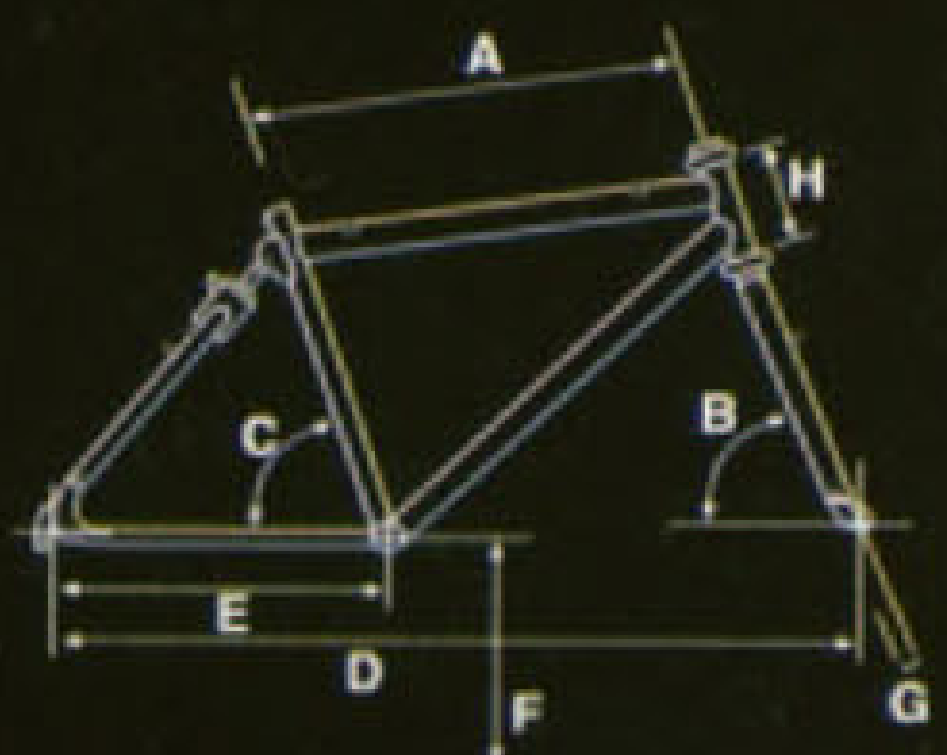

# YETI A.R.C.-A.S. ACTIVE SUSPENSION



Parker says "Start 'em young". Eleven year old Colin Bailey with a full factory ride.



Yeti and Campagnolo go racing. Valentino's a very cool guy!

Mongoose wanted him. Specialized had to have him, the great Johnny "T", on drop bars, riding for Team Yeti.



Las Vegas bets the farm on Sara Ballantyne to win the Worlds. Juli Furtado wins by over three minutes and breaks the bank!



Juli on top in 1999 with Yeti.

"Fast Jack" with Campy's Richard Storino out on a weekend furlough.







So your downhill times have been improving at the local races and none of your friends can stay with you on the training rides. It's time for a real downhill bike! Just in time for our tenth anniversary, John Parker and Mert Lawwill have joined forces to create a downhill-specific machine that is sure to break plenty of records. The Yeti-Lawwill DH, with its quadrilateral, Full Energy Transfer System (F.E.T.S.) tail section, provides a plush three inches of progressive travel. With the super smooth suspension allowing you to go faster than ever, the floating hydraulic disk brake allows you to keep your speed down to a tolerable blur for smooth cornering and the eventual stop at the podium.



Full Energy Transfer System (F.E.T.S.), quadrilateral pivot design with teflon coated, alloy pivot bushings. Ensures that your power gets to the ground.

Rise Terminator air/oil shock body with externally adjustable damping and independently adjustable rebound and compression. The future is here.

Floating, hydraulic disk brake caliper ensures full, fade-free braking power under a variety of conditions.



	16"	17.5"	19"	20"
A	22.6"	22.8"	23.1"	23.5"
B	71°	71°	71°	71°
C	73°	73°	73°	73°
D	42.4"	42.5"	42.5"	42.7"
E	17.0"	17.0"	17.0"	17.0"
F	12.0"	12.0"	12.0"	12.0"
G	1.5"	1.5"	1.5"	1.5"
H	4.5"	4.5"	4.5"	6.0"
Wheelbase	29.75"	31.25"	31.0"	32.25"

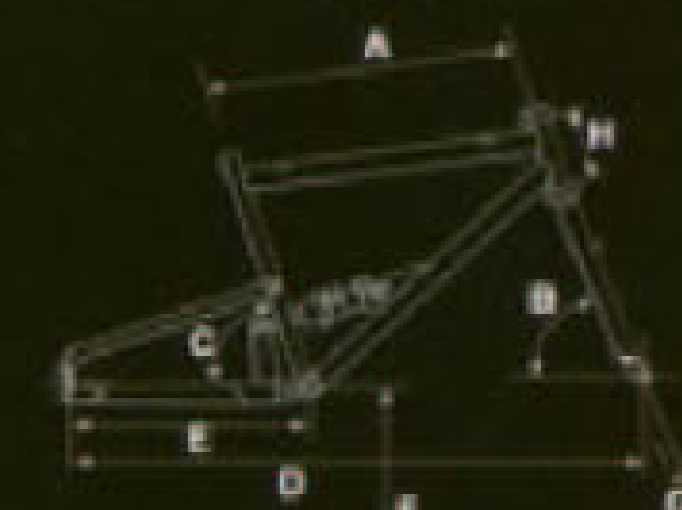

\* depending on set-up  
Seatpost Diameter: 26.8mm - Headset Diameter: 1.25"  
Bottom Bracket Width: 73mm; English Standard Threading  
Front Derailleur Clamp Diameter: 31.8mm/1.25"

**YETI LAWWILL**  
DOWNHILL



**1991**



John Parker's first...  
John Parker and Mert Lawwill...  
John Parker's first...  
John Parker and Mert Lawwill...  
John Parker's first...  
John Parker and Mert Lawwill...



More...  
More...  
More...  
More...



The...  
The...  
The...  
The...

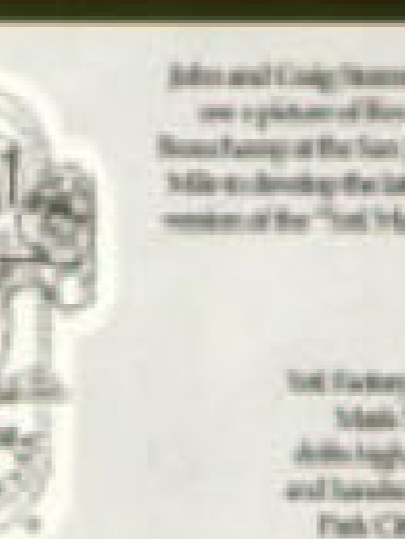

**1992**

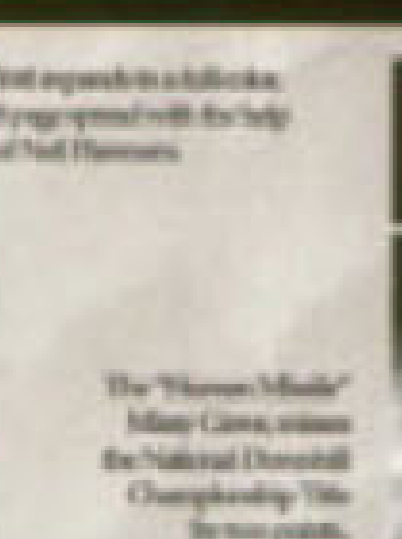



# YETI SHERPA



Sherpa (shur-pa) *n.* a member of a Himalayan people living on the borders of Nepal and Tibet. Just like the Yeti itself, the Sherpa is symbolic of the strength and vigor necessary to thrive in the harsh, alpine climate of the Himalayas. The NEW Yeti Sherpa possesses the same traits of strength and vigor as the people it was named after. Whether you are climbing the steepest of grades or descending from the highest of peaks, the Sherpa is predictable and confidence inspiring. Rest assured that the Sherpa, constructed from Yeti specific, Tange MTB 4130 seamless chromoly, is up for the longest of epic rides, year after year. You wouldn't attempt Everest without a Sherpa, don't attempt your favorite weekend ride without one.

New two-piece, loop tail section ensures massive tire and mud clearance with optimum chainline.

Yeti specified, double-butted, seamless 4130 chromoly tube set from Tange.

New updated 71/73 geometry with 16.8" chainstays for improved handling.

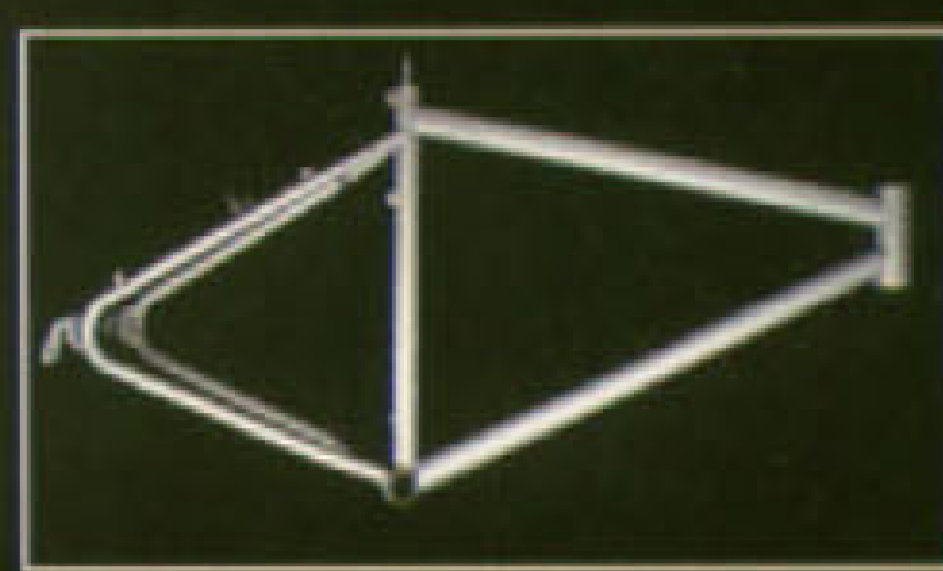

	14"	16"	17.5"	19"	20"
A	21.0"	22.0"	22.6"	23.1"	23.5"
B	71°	71°	71°	71°	71°
C	74°	73°	73°	73°	72°
D	40.75"	41.5"	42.0"	42.25"	42.25"
E	16.8"	16.8"	16.8"	16.8"	16.8"
F	11.0"	11.5"	11.5"	11.5"	11.5"
G	1.5"	1.5"	1.5"	1.5"	1.5"
H	4.0"	4.5"	4.5"	4.5"	6.0"
Stand-over	27.75"	29.25"	29.75"	30.5"	31.75"

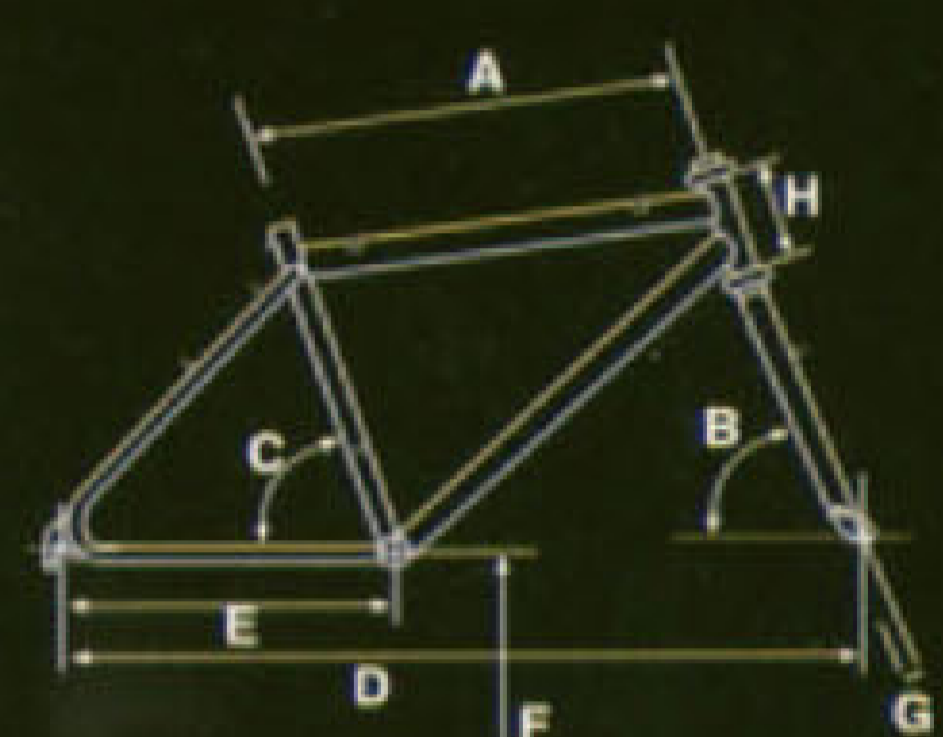

Seatpost Diameter: 26.8mm - Headset Diameter: 1.25"  
 Bottom Bracket Width: 68mm; English Standard Threading  
 Front Derailleur Clamp Diameter: 28.6mm/1.125"



1993



Not a team, but a TRIBE; they won at will! Jimmy Deaton, Sue Fish, Missy Glove and Myles Rockwell at Mammoth Lakes, CA.

Jimmy Deaton's Mammoth Kamikaze gold medal graces the cover our '93 catalog.



"Smiley" Myles Rockwell puts the wood to "Cully" in the Dual Slalom at Hunter Mountain.



Missy Glove is ejected from the Iron Horse Classic and suspended from NORBA. Parker's unhappy and the industry rumbles.



Merry Christmas & Peace on Earth, to all of our friends.

1994





You won't find any caution signs or flagmen on this Road Project, just a flat-out flyer from the folks known for building Mountain Bikes. The Yeti Road Project sports traditional, size-specific

geometry, but don't be fooled, there's nothing else traditional about it. "With its big caterpillar welds, oversize aluminum tubes, and bent chainstays, it sure doesn't look like a '70s Colnago. But it rides that way, and it weighs less than 3 pounds. Merckx should have been so lucky." - January 1995 - BICYCLING. Our ability to specify Custom tube kits from Easton allows us to build a frame that rides like no other. A silky smooth road feel with super efficient lateral stiffness makes for a frame that can be ridden all day, but will handle the out-of-the-saddle field sprints to the city limits sign or across the finish line without sawing your front derailleur in half. Come on, just because we build great Mountain Bikes doesn't mean we don't know our way around the road!

Size-specific, traditional road racing geometry with oversized chainstays for lightning-quick sprints.

Double-tapered seatstays allow for a smooth, compliant ride, while custom-bent chainstays curve inward at the BB, allowing the use of super low-profile cranksets and narrow spindle widths.

Tange Silhouette uni-crown fork lends a classic chromoly ride to the front end.

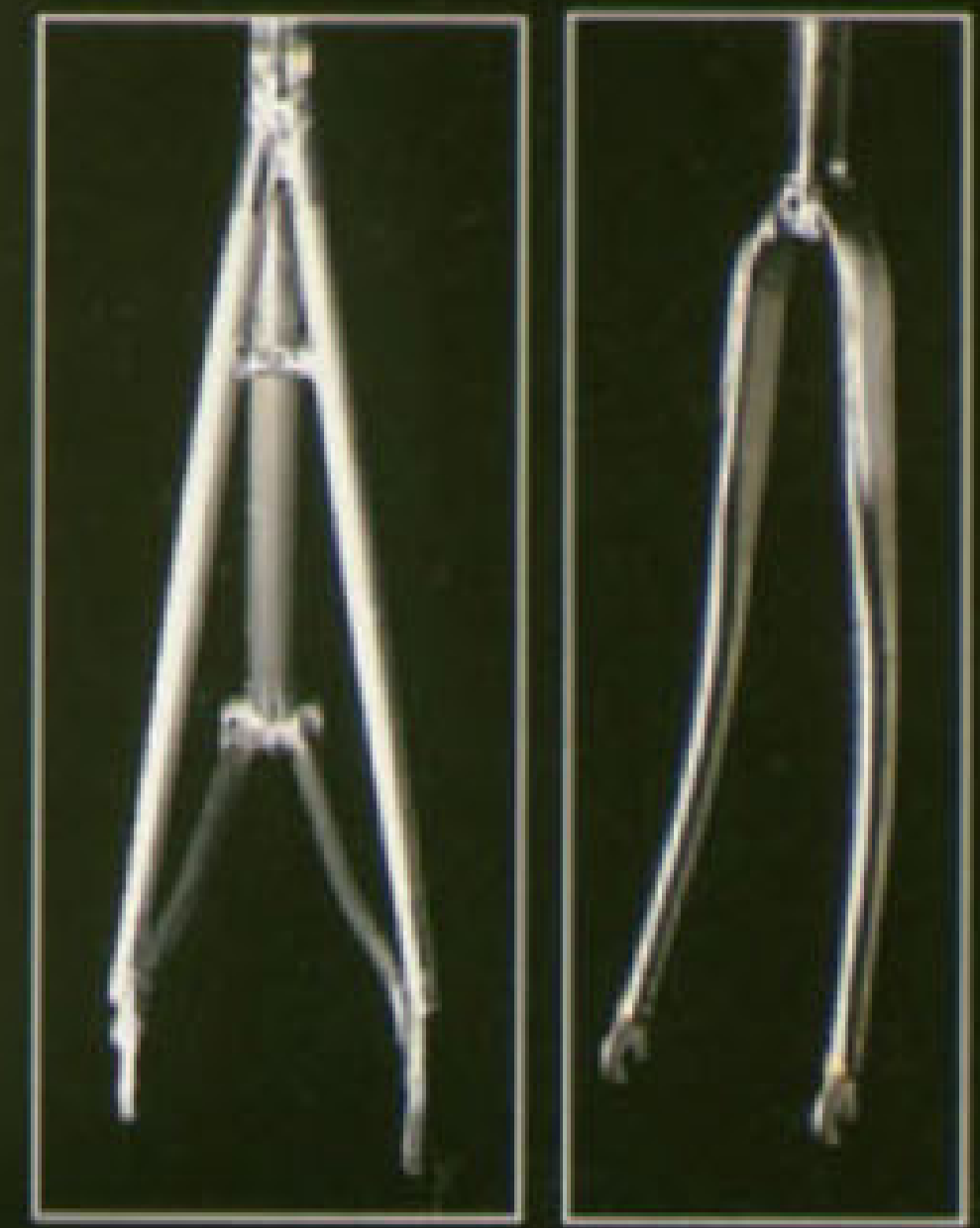
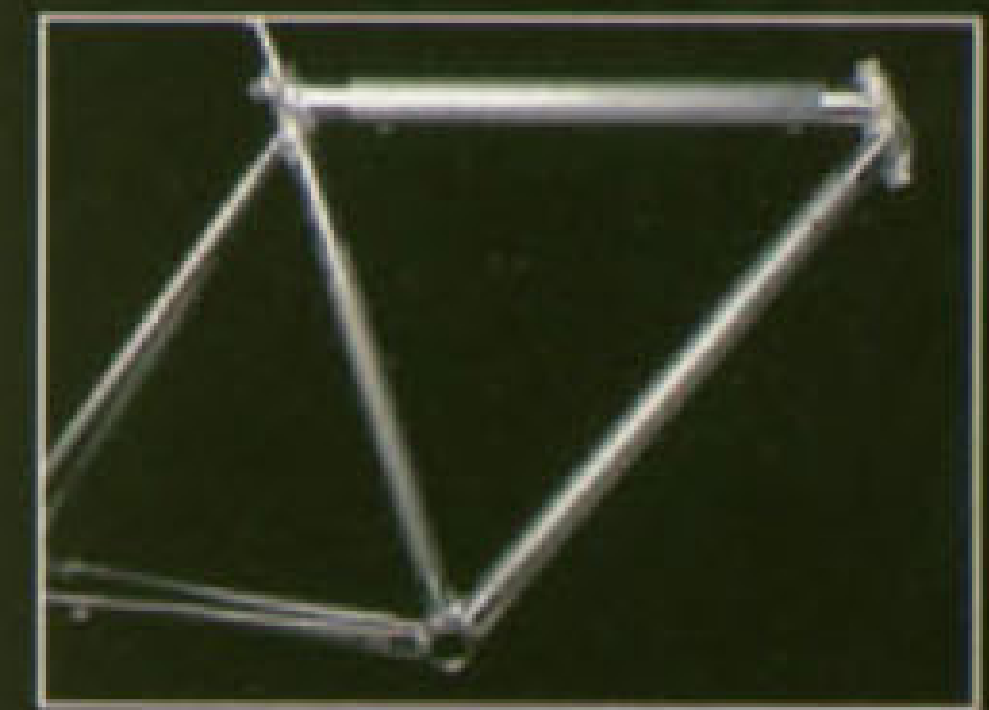

	51cm	53cm	55cm	57cm	59cm	61cm
A	53.3cm	54.3cm	55.6cm	56.5cm	57.4cm	58.5cm
B	73°	73°	73.5°	73.5°	74°	74°
C	74°	74°	73.5°	73°	73°	72.5°
D	97.5cm	98.0cm	98.0cm	98.4cm	99.1cm	100.2cm
E	40.9cm	40.9cm	40.9cm	40.9cm	40.9cm	40.9cm
F	26.9cm	26.9cm	26.9cm	26.9cm	26.9cm	26.9cm
G	4.0cm	4.0cm	4.0cm	4.0cm	4.0cm	4.0cm
H	9.0cm	11.0cm	12.5cm	14.5cm	16.0cm	18.0cm
Stand-over	76.0cm	78.0cm	80.0cm	81.5cm	83.5cm	85.5cm

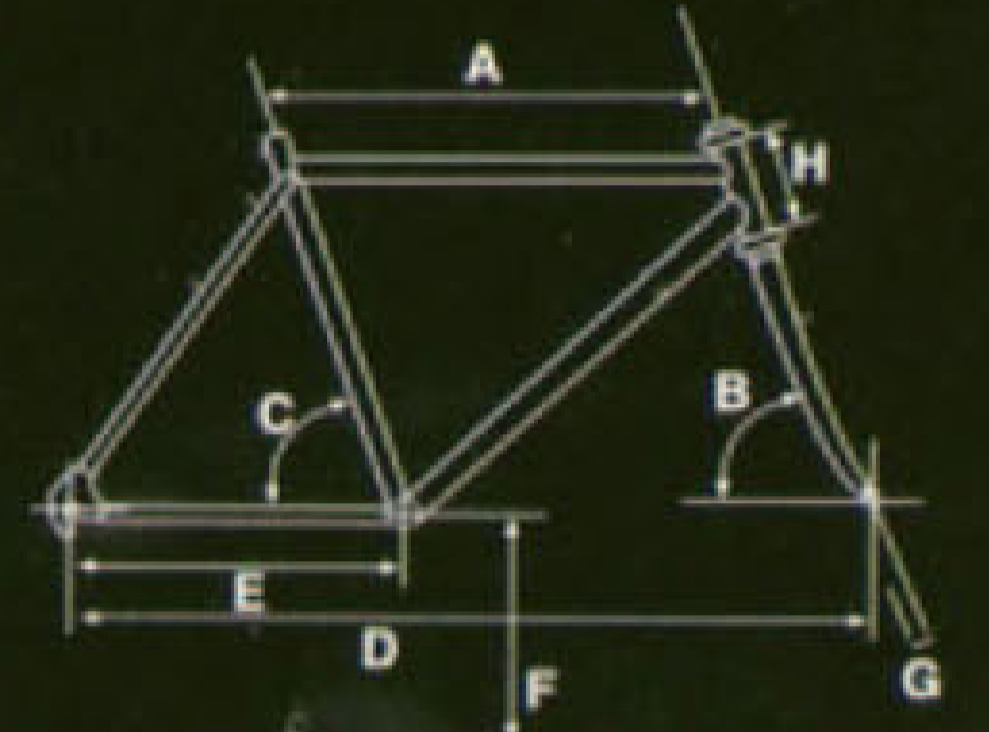

**Seatpost Diameter: 27.2mm - Headset Diameter: 1.0"**  
**Bottom Bracket Width: 68mm; English Standard Threading**  
**Front Derailleur Clamp Diameter: 31.8mm/1.25"**



# YETI ROAD PROJECT

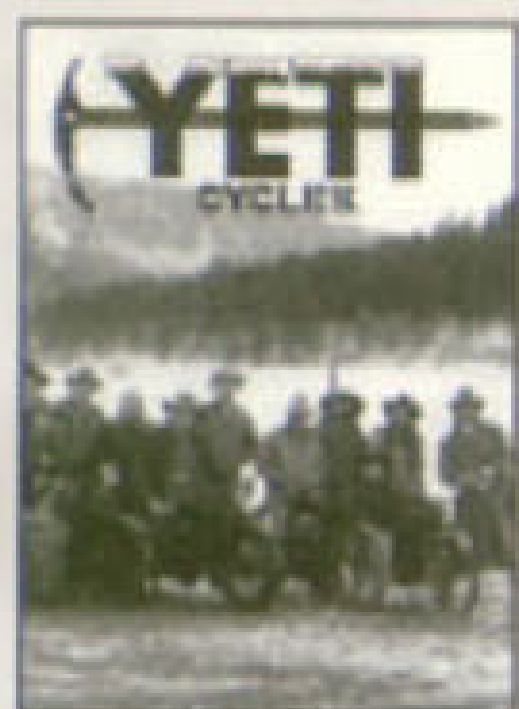

Cowboys and Indians, livin' life BIG in Durango.



Pietro "Chicken Legs" Castellino represents the Yeti/Mapei Italian 1-country effort.

Myles and Missy are kidnapped by aliens from Connecticut, but Yeti continues to bag magazine covers from around the world.



Six-time U.S. National, Supercross and Trophy de Nations Champion, Jeff Stanton, retires from motocross and starts racing for team Yeti.



1995



Dario Cioni on the cover of Bici da Montagna leads a World Cup event in Spain.

Olympic Gold Medalist Tommy Moe gets a gift from the boys at BULA, a brand new Holstein Yeti A.R.C.



Indy Car Driver and Mountain Bike Fanatic Paul Tracy on his day off.







Yeti F.R.O. (For Racing Only) tires. 2.125", Keular beaded, non-directional tread pattern. Great for all conditions!

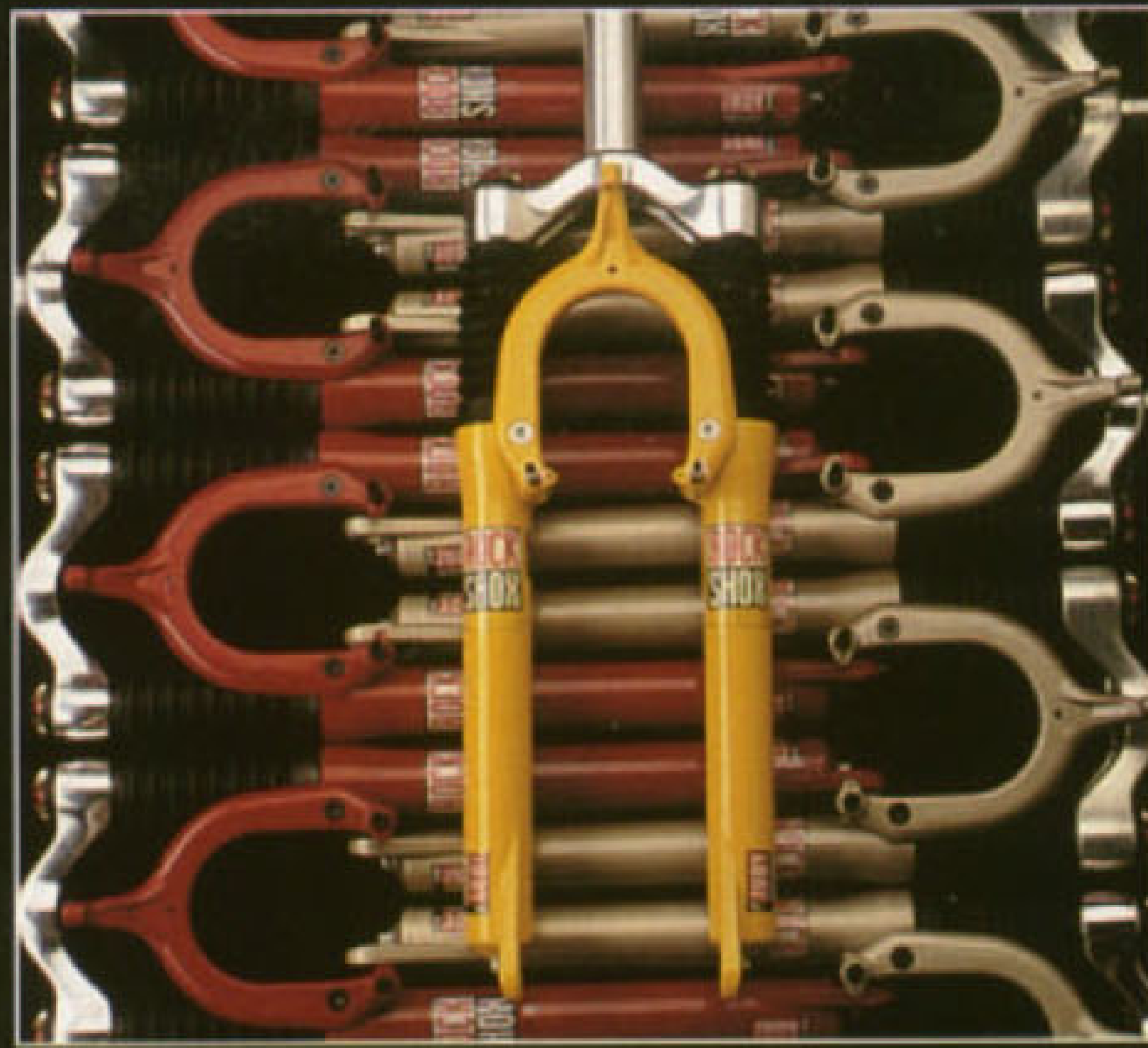

Rock Shox Judy forks, HC, SL and DH models available to complement any Yeti frame. Clearly a winner, surpassed by none.



Yeti/Easton ER70 handlebars. 5-degree bend, shock-absorbing, ultra lightweight - 140 grams. Black, Silver, Turquoise & Red



Yeti/Selle San Marco embroidered saddles. Integra and Concor Light models emblazoned with Yeti's new oval logo and Ice-Ax. Light, sleek, comfortable...YETI!



Craig - Ice Ax Baseball Cap and long-sleeved, 3 button Henley

Sean - short-sleeved, Yeti Man Jersey and Yeti Man tights

Gary - short-sleeved, Yeti Team Jersey and Yeti Team Shorts

Dorothy - short-sleeved, Yeti Man Jersey and Yeti Team Shorts

Betsy - Yeti Team Windbreaker and Yeti Team Shorts

Tim - short-sleeved, 3-button Henley

Bill - Faster and Faster "T"

Gary - short-sleeved, 3 button Henley and Ice Ax Shop Apron

Phil - short-sleeved, Yeti Oval "T"

Steve - Ice Ax Baseball Cap and Yeti Oval Mock Turtleneck

Tom - short-sleeved, Yeti / Swobo Merino Wool Jersey and Yeti Team Shorts





Yeti/001 Speed Grips, open-end & Grip Shift 500, 600 & 800 compatible. Black, Clear & Turquoise (Red & Yellow soon). MBR's #1 grip hands down!

Yeti Powdercoat Frame Colors

- Huckabay Blue (metallic)
- GM Silver (metallic)
- Jasper Green (metallic)
- Plum Violet (metallic)
- Pure White
- Gloss Black
- Battleship Gray
- Team Yellow
- Forest Green
- Desert Turquoise
- Royal Blue
- Pumpkin Orange
- Bright Red



Yeti Sticker Kits. Seven piece kits including a temporary Yeti Man tattoo. Adorn your bike, car or refrigerator with your favorite Yeti logo.



"Large Ice Ax Banner"

E.B. - Ice Ax baseball Cap and short-sleeved, Yeti Man "T"

Dawn - Yeti Volleyball Cap and Faster and Faster "T"

Barbara - Ice Ax Sweatshirt and Yeti Gear Bag

Linda - short-sleeved, 3-button Henley

Chris - Ice Ax Baseball Cap, short-sleeved, Yeti Man Tie-Dye "T" and Ice Ax Waterbottle

James - Yeti Oval Baseball Cap, Yeti Oval "T" and Ice Ax Coffee Mug

Rick - Ice Ax Hybrid Cap, Yeti Ice Ax "T" and Yeti Man Coffee Mug

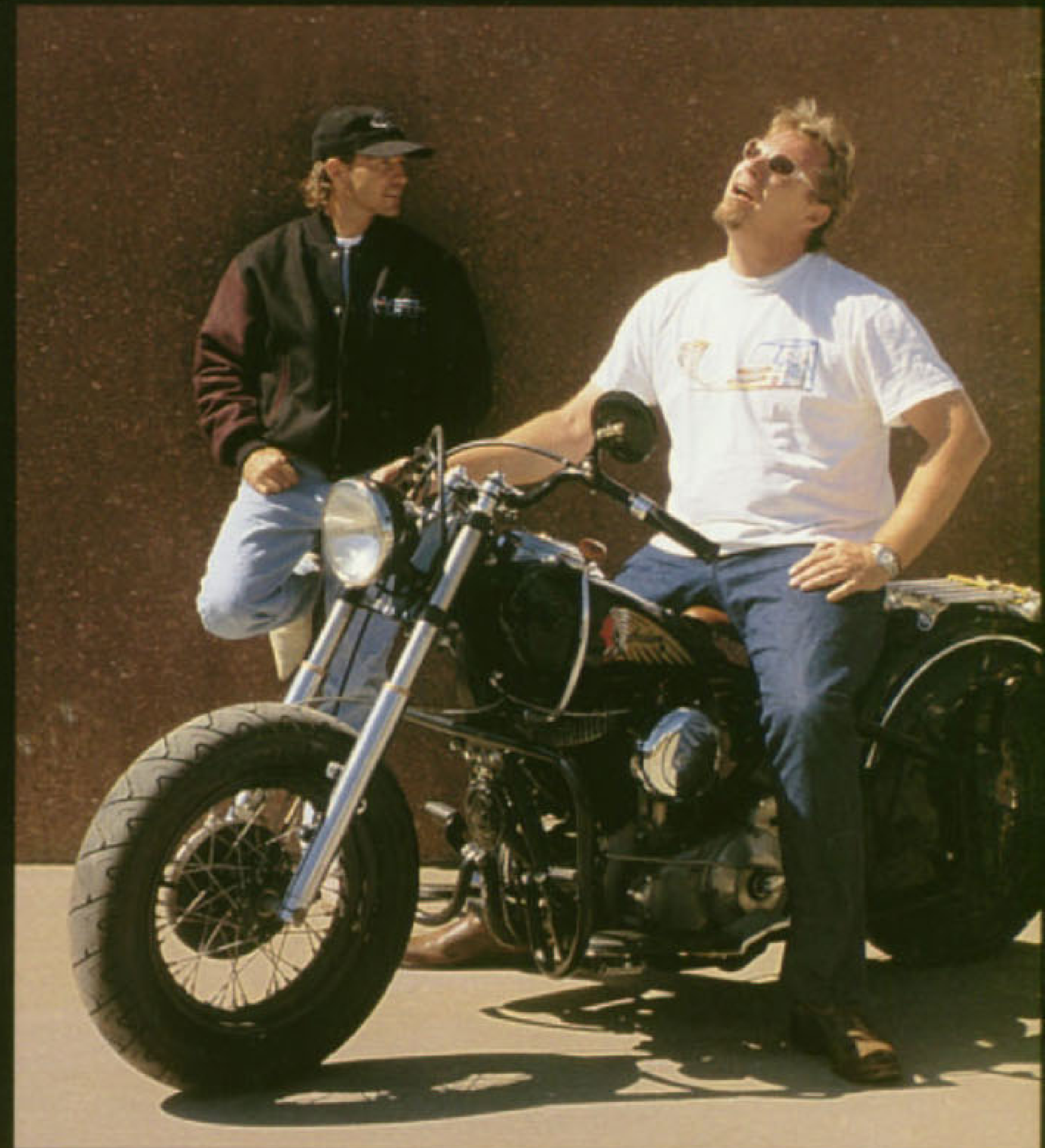

Brett - Yeti Oval Baseball Cap and Wool Baseball Jacket

Parker - 1948 Indian Chief (Leiland McSpadden T-shirt unavailable)

NOT PICTURED: Yeti Ice Ax Shot Glass - Yeti Ice Ax Headband





194 Bodo Drive Durango, CO 81301 Phone 970-259-1914 Fax 970-259-4550

Photos by: Jim Sadlon - Copy by: K. Brett Hahn - Design by: Neil Hannum Tim Lay - This catalog was designed on a Power Mac 8100/128AV with Quark X-Press, Adobe Photoshop & Adobe Illustrator

Printed on Recycled Paper 