

YETI CYCLES

HAS THE FRAME FOR YOU

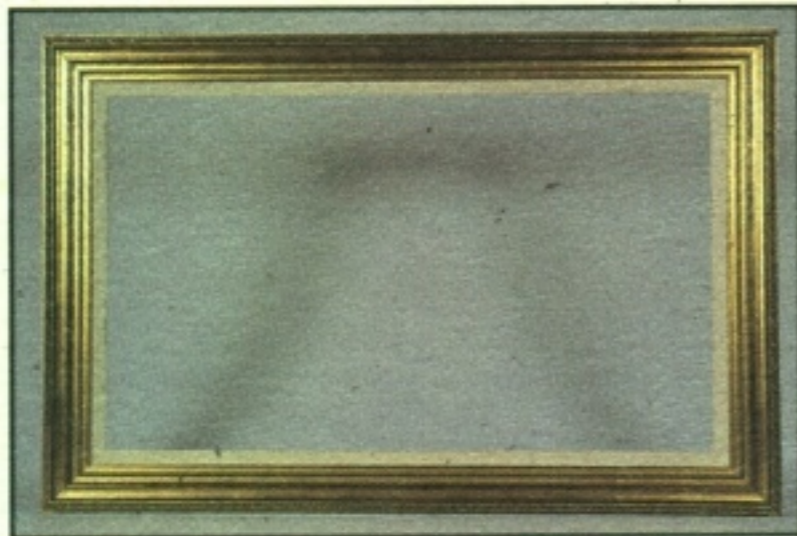

Granny Issue



Late 60's



YETI A.R.C.

WHETHER YOU ARE A WORLD CLASS RACER, THE TERROR OF THE SPORT CLASS, OR A HARDCORE ENTHUSIAST, YETI BUILDS EACH AND EVERY ONE OF OUR FRAMES AS THOUGH YOU WERE A MEMBER OF OUR WORLD CHAMPIONSHIP WINNING, FACTORY RACE TEAM. WE DO NOT COMPROMISE QUALITY MATERIALS OR HANDMADE CRAFTSMANSHIP TO BUILD LESS EXPENSIVE FRAMES PRICED FOR THE MASSES. INSTEAD, WE USE YETI SPECIFIED CUSTOM-DRAWN TUBING, PRECISION MACHINING, AND COMPUTER-CONTROLLED TUBE BENDING TO CONSTRUCT WHAT WE BELIEVE ARE THE FINEST FRAMESETS AVAILABLE. AT YETI WE DON'T BUILD REPLICAS AND WE DON'T QUIT WHEN THE OTHERS GO HOME.

BE PROUD OF YOUR PRO.F.R.O.

All YETI bicycles are handmade in Durango, Colorado by an eccentric crew of passionate craftsmen. And this is not strictly a bunch of tech weenies, they also eat dirt!



YETI "Pro For Racing Only"

The Yeti Pro F.R.O. is our benchmark frame design, the latest in a series of progressively innovative Yeti racing framesets. The Yeti Pro F.R.O. has been through seven years of changes and continues to improve, while still remaining one of the most stable and predictable chromoly frames on the handmade market. It is constructed of a Yeti-designed, seamless, double-butted, chromoly tubeset from Tange, which allowed us to shave a full half pound from the frame. The Pro F.R.O. has traditional Yeti features including racer-friendly geometry, Yeti-cross cable routing and a one-piece computer-bent tail section with ample tire clearance. In a world of exotic materials and custom framesets that cost as much as your first car, Yeti has chosen to keep a frame in our line-up that not only satisfies your every handling dream, but is also considerate of your bank account. Some say nothing rides like steel, we say nothing rides like a Yeti.

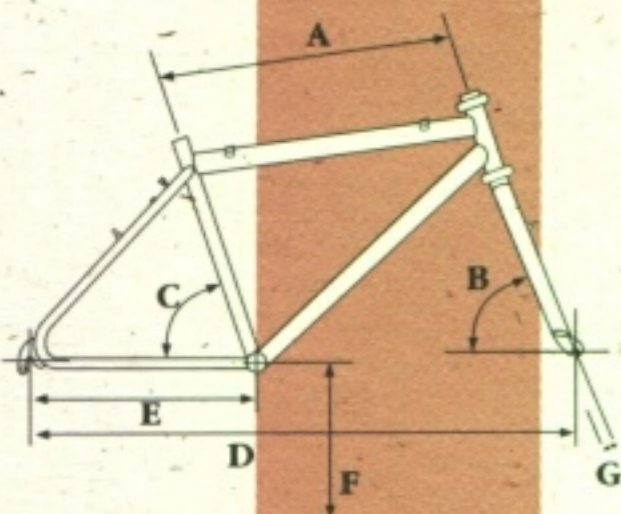

	14"	16"	17.5"	19"	20"	22"
A	20.5"	22.4"	22.6"	22.9"	22.7"	23"
B	72°	71°	71°	71°	71°	71°
C	74°	72°	72°	72°	73°	73°
D	40.4"	41.6"	41.6"	41.6"	41.6"	41.6"
E	17.2"	17.2"	17.2"	17.2"	17.2"	17.2"
F	11.0"	11.5"	11.5"	11.5"	11.5"	11.5"
G	1.25"	1.25"	1.25"	1.25"	1.25"	1.25"



Jimmy Deaton, three-time Mammoth Mountain Kamikazi Downhill Champion & Shipping Engineer.

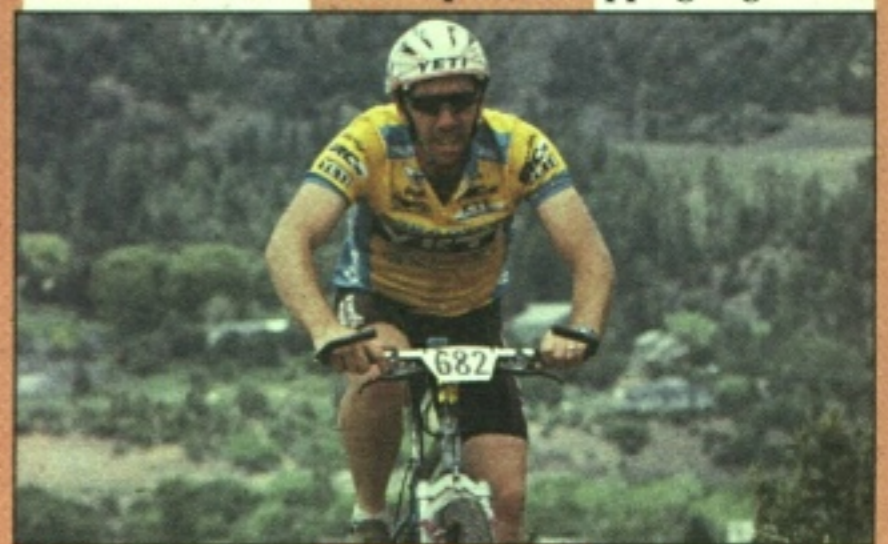

Frank Wadelton, Welder Extraordinaire and Manic Downhill Master.



Heath Franklin, Dual Slalom Specialist and Disciple to F.T.W.

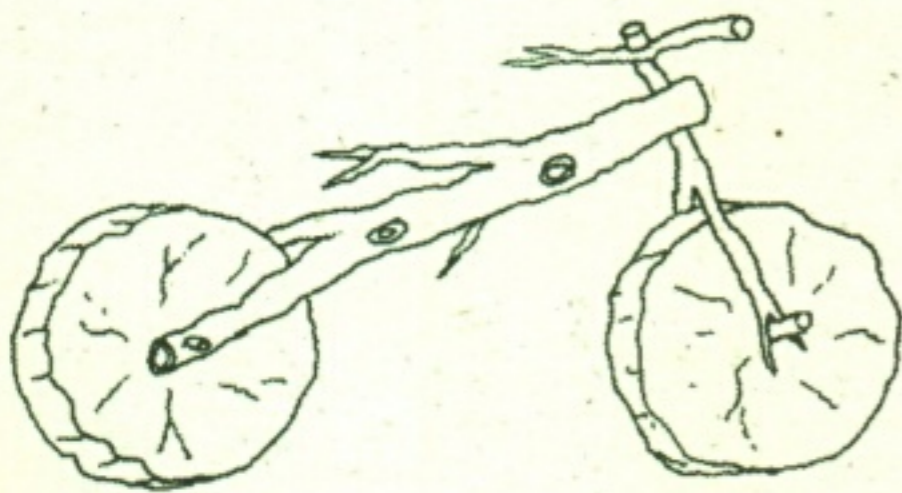

When man first rode the earth the elevated bike was the obvious choice for maximum tire clearance.

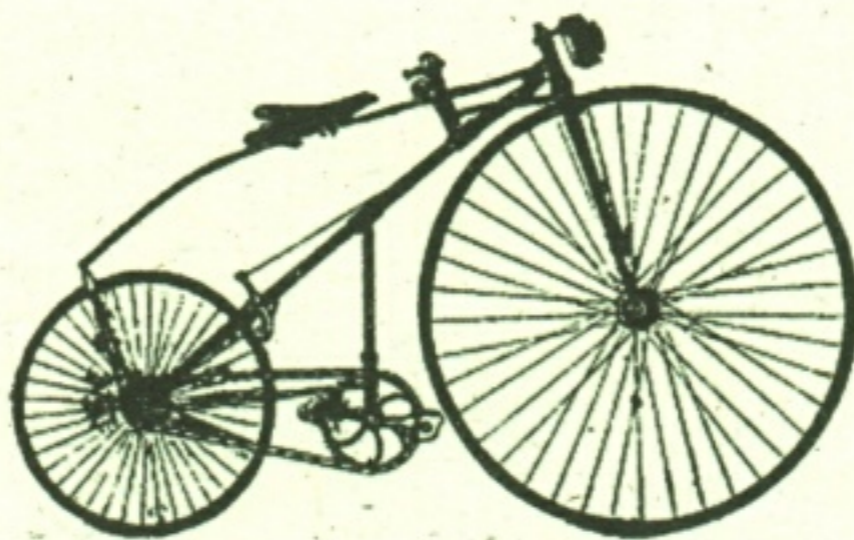

By the 1800s man introduced chain drive and realized that chain suck was an unacceptable phenomenon.



ALWAYS DISMOUNT FOR HORSES

YETI Ultimate

Originally built as a project bike for **Mountain Bike Action Magazine**, this bike has gone on to become the most widely copied design in the industry. Although the imitations are flattering, the project bike was not perfect. Yeti has taken the necessary extra steps to bring the elevated design into the winner's circle. The addition of a computer-bent tail section and down tube has added strength and rigidity where it is needed; there's no chain suck or swaying bottom brackets here. Standard Yeti-cross cable routing and generous tire clearance round out the entire package. Whether you are bombing down the gnarliest, most mind-twisting single tracks or grunting up the steepest, most technical climbs on race courses throughout the world, the Yeti Ultimate will elevate you to the top.

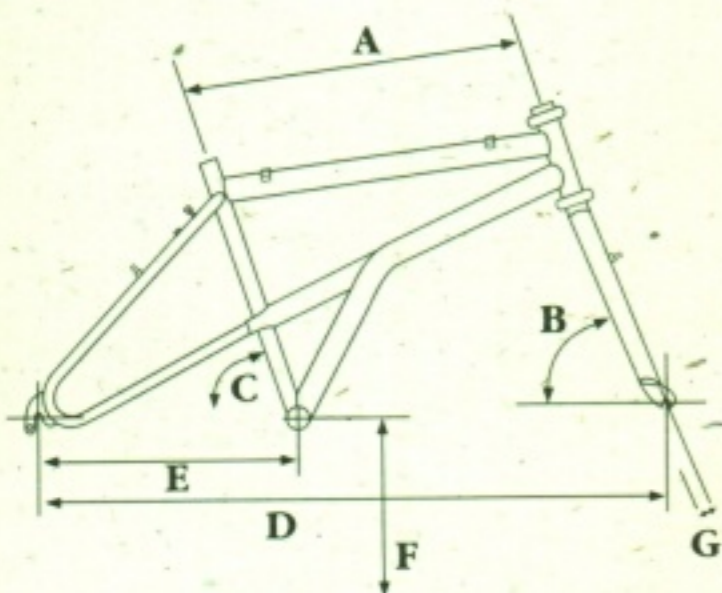

WHEN I FIRST DISCOVERED MY THEORY OF EVOLUTION I TALKED TO JOHN AND THE BOYS AT YETI AND KNEW THEY COULD DO WONDERS.

	16"	17.5"	19"	20"
A	22.4"	22.6"	23"	23.25"
B	71°	71°	71°	71°
C	73°	73°	73°	73°
D	41.5"	41.5"	41.5"	41.5"
E	16.5"	16.5"	16.5"	16.5"
F	11.5"	11.5"	11.5"	11.5"
G	1.25"	1.25"	1.25"	1.25"

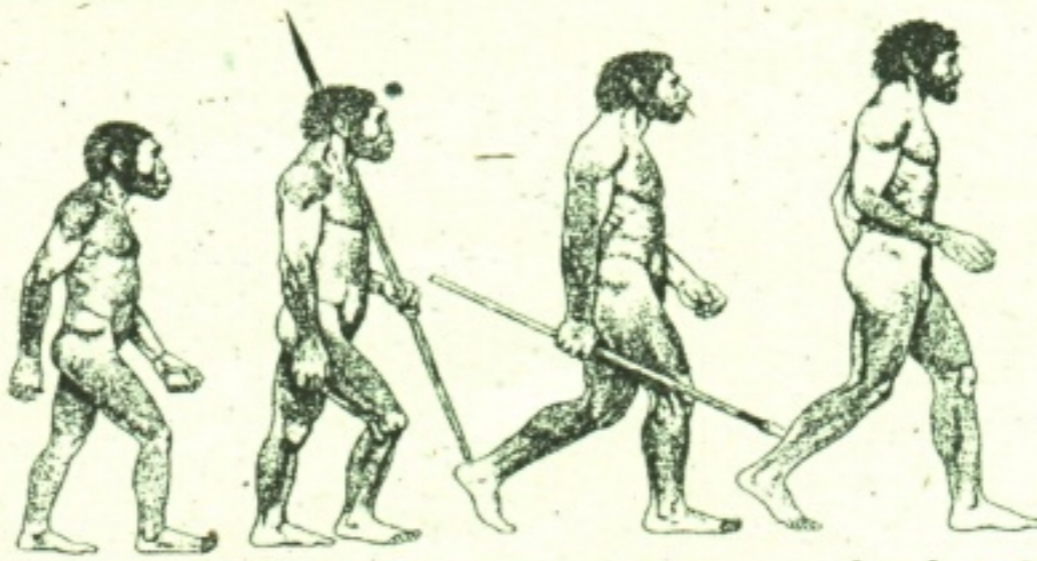

After coming this far you deserve the best!

Darwin's

**U
L
T
I
M
A
T
E**

Theory on the elevated chainstay bicycle.

CRAZED WELDER

BUILDS 1st A.R.C.



YETI A.R.C. "Alloy Racing Composites"

In keeping with our usual fanatic fashion, Yeti and our factory race team spent a full year researching, designing, and racing on the A.R.C. prior to releasing this frame to the public in the beginning of '92. In its first year of production the Yeti A.R.C. won more NORBA National, Grundig Cup and World Cup events than all of the competition combined. You won't find the harsh, buckboard ride of typical straight-gauge, 6000 series Aluminum in our flagship! The A.R.C. is masterfully constructed of Easton's 7005 Series ProGram Varilite tubing throughout the entire frame. Yeti called upon the wizardry of Easton Aluminum's Chuck Teixeira to draw an exclusive tubeset to our exacting requirements, which actually yielded a tube that is 25 percent stiffer and lighter than chromoly. We put the material where it matters, and the racers where they belong: on the podium.

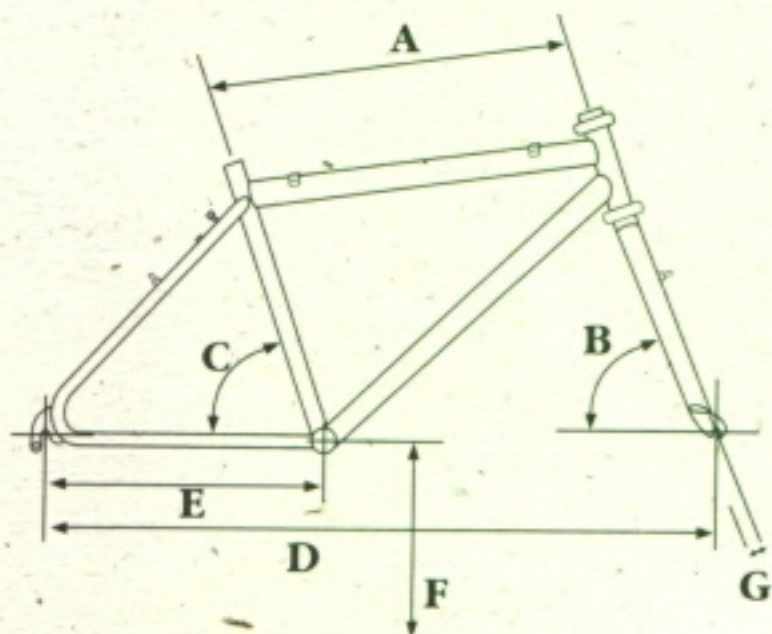

	14"	16"	17.5"	19"	20"
A	20.5"	22.6"	22.8"	23.1"	23.1"
B	72°	71°	71°	71°	71°
C	74°	73°	73°	73°	73°
D	40.0"	41.75"	41.75"	41.75"	41.75"
E	16.8"	16.9"	16.9"	16.9"	16.9"
F	11.0"	11.5"	11.5"	11.5"	11.5"
G	1.25"	1.25"	1.25"	1.25"	1.25"

F.
T.
W.



Some think of him as an
**AMERICAN
HERO**

NOTE!



Some trademark controversy over the usage of the name "ARC" has arisen in the last few months. Noah has filed suit in District 36. A court ruling is expected by the end of the year.

WE ARE HEREBY SUSPENDING YOU

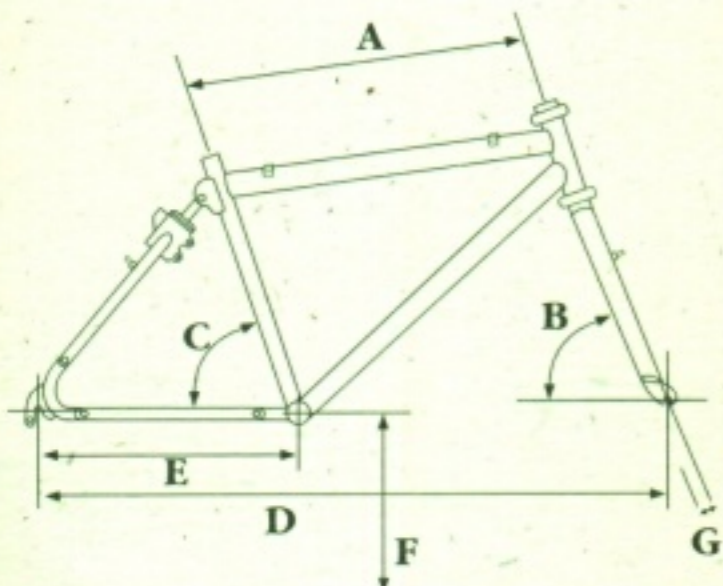

	16"	17.5"	19"	20"
A	22.6"	22.8"	23.1"	23.2"
B	71° *	71° *	71° *	71° *
C	73° *	73° *	73° *	73° *
D	42.2"	42.2"	42.2"	42.2"
E	17.2"	17.2"	17.2"	17.2"
F	11.5"*	11.5"*	11.5"*	11.5"*
G	1.5"	1.5"	1.5"	1.5"

* Dimension may vary slightly due to suspension set-up



YETI A.R.C.-A.S. "Active Suspension"

Yeti isn't introducing rear suspension because it's "the thing to do." We are taking full advantage of our relationship with world class motocross racers and their sophisticated motorcycle suspensions, to refine what other manufacturers are choosing to call "rear suspension". The Yeti A.R.C.-A.S. is built around the same race-proven geometry and material with which our original A.R.C. continues to wreak havoc on race courses around the world. Available with your choice of damping: Yeti/I.R.C. elastomer or Risse air/oil. The A.R.C.-A.S. is easily dialed to rider weight and to course conditions, cross country and downhill alike.

YOUR VERY OWN RULER TO MEASURE UP THE COMPETITION

HIGH SCHOOL WAS NEVER THE SAME

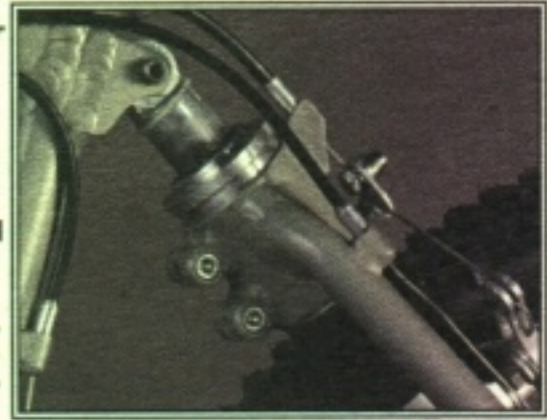
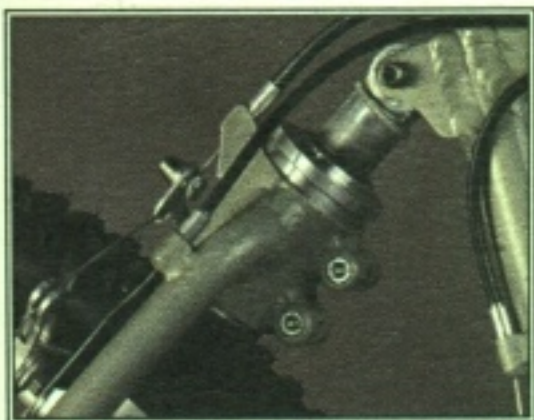

While most companies are choosing your suspension for you, Yeti offers you the best of both worlds: two interchangeable options. The Yeti/IRC Elastomer shock utilizes a custom-formulated elastomer material that gives a wide range of damping characteristics with virtually maintenance-free action. The state-of-the-art Risse air/oil shock offers simple adjustability, light weight and race-winning performance.



When Missy's mother heard that she had been suspended, she assumed the worst.

Missy

Is from the East, didn't like school, hated studying, did things her own way and rode the Yeti/IRC elastomer suspended A.R.C. to first place in the Reebok Dual Eliminator.



MISSY "THE MISSILE" GIOVE:

Winner, 1992 Mammoth Mtn. Reebok Challenge
New course record: 5:00:42. Top Speed: 53.5 mph

JAMMIN' JIMMY DEATON:

Winner, 1992 Mammoth Mtn. Kamikazi Downhill
New course record: 4:54:20. Top Speed: 56 mph

Jimmy

Is from the West, loved school, did his homework, will try anything once and rode the Risse air/oil suspended A.R.C. to first place in the Mammoth Mountain Kamikazi Downhill.

Do Not Leave Home Without It



TEAM YETI JERSEY
"ALWAYS FLY THE RIGHT COLORS"



TEAM YETI WINDBREAKER
"KEEPS THE RAIN OFF AND THE WIND OUT"



TEAM YETI SHORTS
"REAL MEN WEAR CHAMOIS"



YETI-MAN "T"
"THE YETI LIVES"



When you're in a pinch YETI shorts work well up or down.



ICE-AX "T"
"THE ORIGINAL CHOICE"

SOMEWHERE ON THE '93 HORIZON



YETI FACTORY TEAM SWEAT



YETI RACE BANNERS
AVAILABLE NOW



YETI FACTORY LIDS
"ANTI-MELANOMA DEVICE"



YETI HANDLEBAR
"WE'LL NEVER STEER YOU WRONG"

YETI PAW COVERS
"PRACTICE SAFE HANDLING"



YETI SHOT GLASSES
"FOR THE BEVERAGE OF YOUR CHOICE"



YETI TOOL SHEDS



THEY JUST DON'T BUILD THINGS LIKE THEY USED TO!



Bitchin' New Stuff

ALL YOUR HARDWARE Needs

IF YOU WANT TO RUN THE SAME RACE-WINNING PARTS COMBINATIONS THAT TEAM YETI WINS WITH EVERY DAY, THEN TAKE A LOOK AT THE YETI-READY SPEED PIKS.

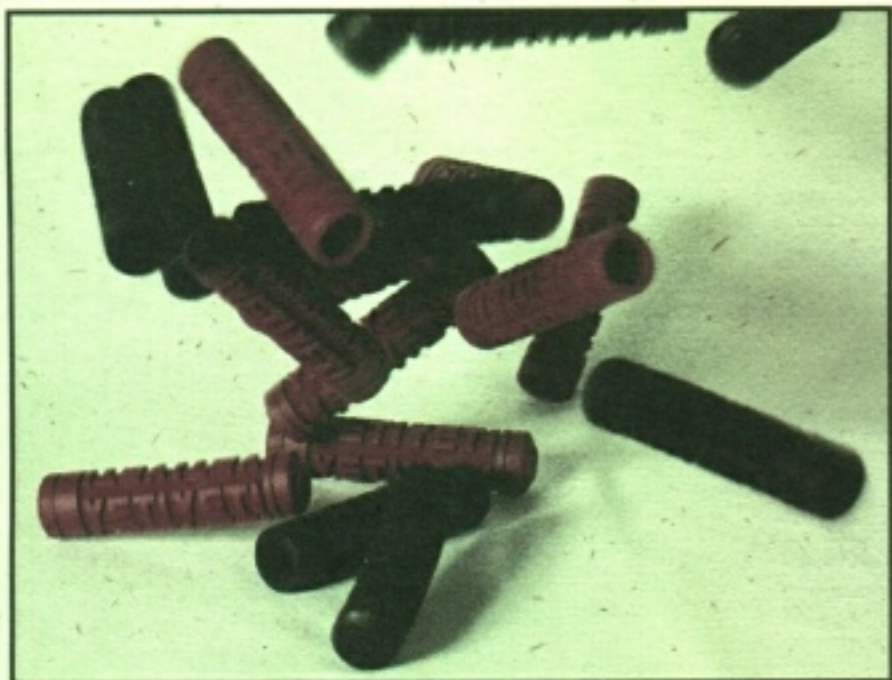

SPEED GRIPS
"MADE IN THE U.S.A"

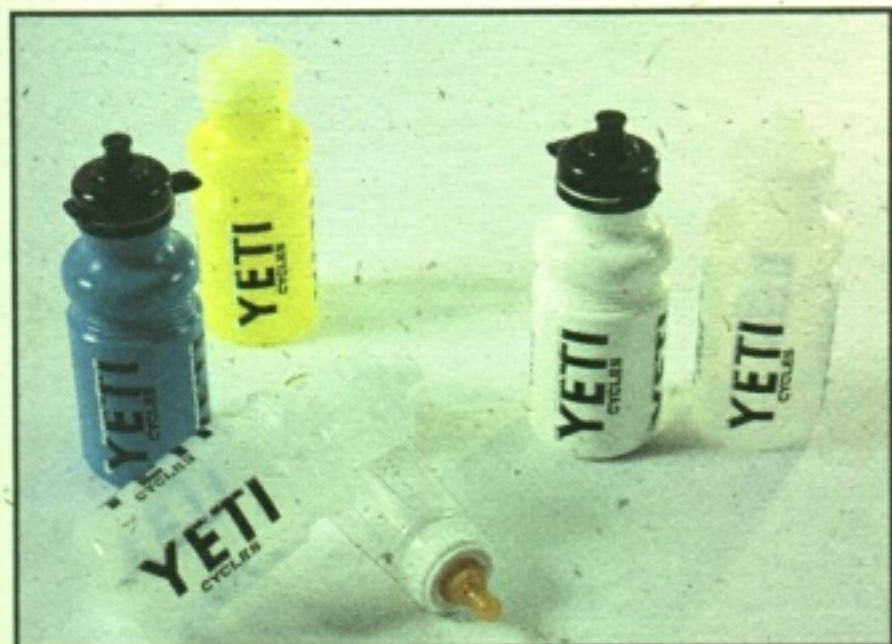

ICE-AX WATER BOTTLES
"BIG MOUTHS FOR BIG THIRSTS"



CHRIS KING SEALED BEARING HEADSETS
"SIMPLY THE CADILLAC"

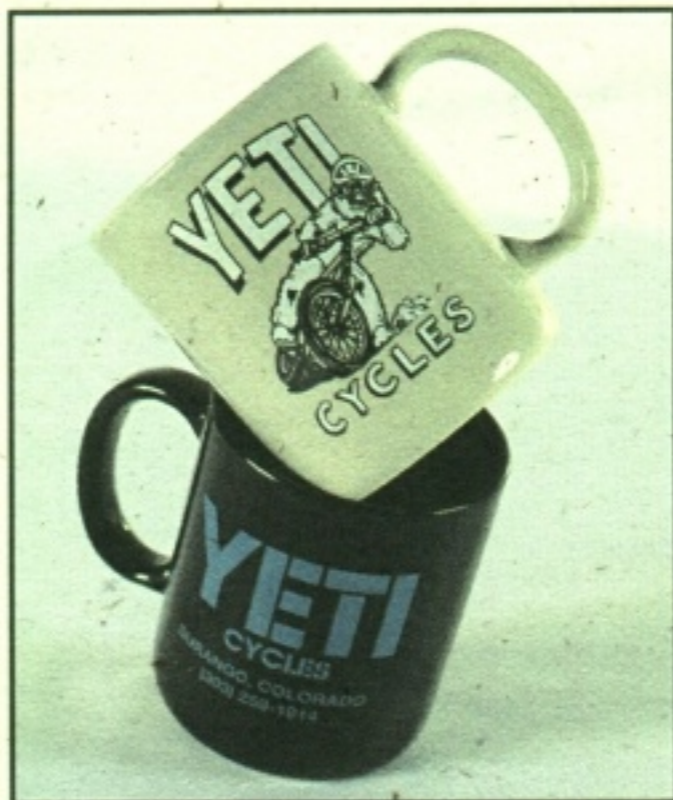

YETI COFFEE MUGS
"THE CHOICE OF SERIOUS COFFEE DRINKERS"



"PARKER, WOULD YOU JUST GET A GRIP?!!
I'M GOING AS FAST AS I CAN."

YETI CYCLES WILL BE OFFERING SELECT PARTS FROM GRAFTON PERFORMANCE AND RINGLE' COMPONENTS WHICH WILL BE CUSTOM FITTED FOR OUR FRAMES TO OUR DEMANDING PERFORMANCE SPECIFICATIONS.

GRAFTON

- SPEED CASE SEALED BEARING BOTTOM BRACKETS
- JOYSTICKS PRECISION CRANKSETS
- SPEED CONTROLLERS BRAKESETS

RINGLE'

- TI-STIX SKEWER SETS
- ULTRALIGHT H2O CAGES
- MOBY POST SEAT POSTS
- SUPER BUBBA SUSPENSION HUBS

YETI

- YETI/IRC TIRES
- "FOR RACING ONLY"

"3 YEARS OF TEAM YETI USE AND STILL THE FORK OF CHOICE!"

ANSWER/MANITOU SUSPENSION FORKS

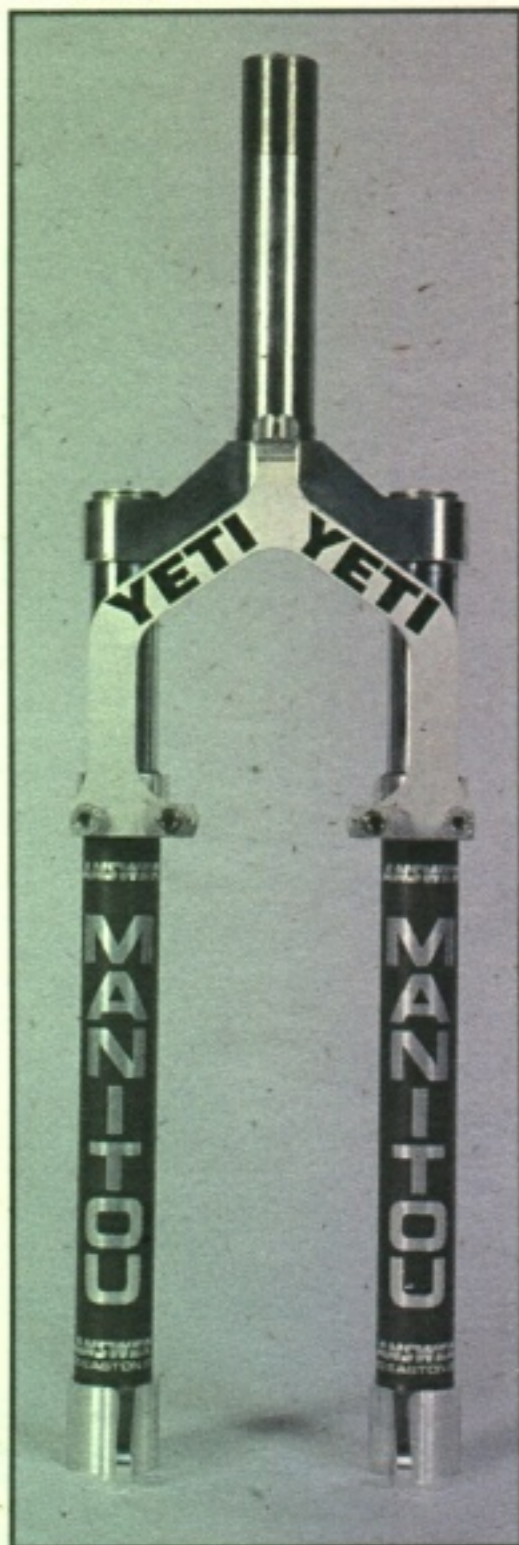

TRACK FACTS

EACH YETI FRAMESET INCLUDES FRAME, OUR LEGENDARY STRAIGHT-BLADE FORK (MANITOU SUSPENSION FORK OPTIONAL), EVOLUTION HEADSET, CABLE FERRULES AND ASSEMBLY INSTRUCTIONS. ALL YETI FRAMESETS ARE SOLD WITH A LIMITED ONE-YEAR MATERIAL AND WORKMANSHIP WARRANTY. DON'T BE A KOOK, PROMPTLY FILL OUT AND RETURN YOUR WARRANTY CARD OR PERISH IN THE FLAMES OF IGNORANCE. ALL YETI FRAMESETS ARE FINISHED WITH AN ELECTROSTATIC EPOXY POWDER COATING. YETI ALSO OFFERS POWDER COATING SERVICE TO CUSTOM FRAMEBUILDERS AND PRIVATE PARTIES. CONTACT MR. RICK KRAMER OF YETI CYCLES FOR FURTHER DETAILS.

SEATPOST DIAMETER: 26.8MM
 HEADSET DIAMETER: 1.25"
 REAR AXLE SPACING: 135MM
 BOTTOM BRACKET WIDTH: PRO F.R.O. & ULTIMATE 68MM;
 ENGLISH STANDARD THREADING
 A.R.C. & A.R.C.-A.S. 73MM;
 ENGLISH STANDARD THREADING
 FRONT DERAILLEUR CLAMP DIAMETER:
 PRO F.R.O. & ULTIMATE
 28.6MM/1.125"
 A.R.C. & A.R.C.-A.S. 31.8MM/1.25"
 STRADDLE HEIGHTS: CALL FOR DETAILS.



NO RUNS, NO DRIPS, NO IMRON. TAKE YOUR CHOICE.



UNITED KINGDOM
 CYCLELAND
 MARK PEARCE
 TEL. 44-081-290-0807
 FAX. 44-081-464-8550



SWEDEN
 ACTIVE PRO STUFF
 ANDREAS NYBERG
 TEL. 46-31-183358
 FAX. 46-31-183286



U.S.A
 YETI CYCLES
 BRETT HAHN
 TEL. 303-259-1914
 FAX. 303-259-4550



SPAIN
 DIRT RACING PRODUCTS
 MIGUEL ROJO
 TEL. 34-1-383 04 26
 FAX. 34-1-766 90 49



HONG KONG
 FLYING BALL BICYCLE Co.
 SHEUNG LUM LEE
 TEL. 852-381-3661 OR 5919
 FAX. 852-397-4406



ITALY
 107 IMPORT S.R.L.
 DANIELE CAMERANA
 TEL. 39-11-899-0063
 FAX. 39-11-899-0063



SWITZERLAND
 MTB CYCLETECH AG
 BERNARD GAUDY
 TEL. 41-31-44 08 04
 FAX. 41-31-43 58 18



SINGAPORE
 MOUNTAIN BIKE PRO CTR.
 DENISON SEAH
 TEL. 65-242-3818
 FAX. 65-272-8793



AUSTRIA
 MOTOPART
 DAUD AL-ZUBEIDI
 TEL. 43-222-67 66 28
 FAX. 43-222-67 06 96



NORWAY
 SYKKELDELISK
 KARL AUBERT
 TEL. 47-2-42 60 20
 FAX. 47-2-41 33 45



GERMANY
 GERMAN'S MTN. BIKES
 GERMAN MÖHREN
 TEL. 49-6221 16 65 18
 FAX. 49-6221 16 65 19



INDONESIA
 INDOCANA IMPORT & EXPORT
 BILL HUSADA
 TEL. 604-327-1021
 FAX. 604-327-1718



AUSTRALIA
 SPEKTRUM SPORTS ENTERPRISES
 ANDREW BLOXHAM
 TEL. 61-2-44-7204
 FAX. 61-2-449-7605



BELGIUM
 AEROLINE
 STEPHAN JOURQUIN
 TEL. 32-54-32 81 04
 FAX. 32-54-32 64 08



NETHERLANDS
 AEROLINE
 STEPHAN JOURQUIN
 TEL. 32-54-32 81 04
 FAX. 32-54-32 64 08

JAPAN
 MIZUTANI BICYCLE Co.
 TOSHI MIZUTANI
 TEL. 81-3-840-2151
 FAX. 81-3-840-2158

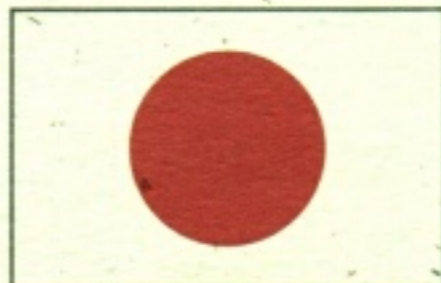

JAPAN
 INOAC SPORTS INC.
 MR. KITAMURA
 TEL. 81-052-581-3290
 FAX. 81-052-581-0750

JAPAN
 A & F CORPORATION
 TAKAO AKATSU
 TEL. 81-3-3209-7575
 FAX. 81-3-3209-7497



HANDMADE IN DURANGO

194 Bodo Drive Durango, CO 81301 Phone 303-259-1914 Fax 303-259-4550

PHOTOS BY: GUNNAR CONRAD, BOB ALLEN, TOM MORAN, TERRY & SUZI MOORE - COPY BY: BRETT HAHN - DESIGN BY: NEIL HANNUM - THIS CATALOG WAS DESIGNED ON A MACINTOSH II CI WITH QUARK X-PRESS - ADOBE PHOTOSHOP & ADOBE ILLUSTRATOR.

Printed on Recycled Paper.

