

SUNTOUR ACCUSHIFT PLUS X-PRESS CONTROL LEVER

Model:SL-PP10-R7U (Code No. 33119571) 7Speed/Right
 Model:SL-PP10-R6R (Code No. 33119561) 6Speed/Right
 Model:SL-PP10-L (Code No. 33119701) Left
 Model:SL-PP00-R7U (Code No. 33519571) 7Speed/Right
 Model:SL-PP00-R6R (Code No. 33519561) 6Speed/Right
 Model:SL-PP00-L (Code No. 33519701) Left

INSTRUCTIONS FOR SUNTOUR X-PRESS CONTROL LEVERS



Note:

- All threaded fittings and all control cables should be greased prior to assembly.
- Make sure that the front and rear derailleurs' high and low gear limit screws are correctly adjusted (see derailleur instructions) and that the rear derailleur cable adjusting barrel is turned two full turns counter-clockwise from its innermost position.
- For correct positioning of the X-PRESS shift lever, the minimum length of the straight section of the handlebar should measure (grip length) + (brake lever clamp length) + 50mm. Select a handlebar that meets this requirement.

1 SHIFTING OPERATION

With the X-PRESS control lever, shifting gears is as simple as pushing a lever.

LEFT LEVER The left lever controls the front derailleur. Push lever A to upshift the chain from the smallest chainring to the largest chainring (Fig. 1-A). Push lever B to downshift from the largest chainring to the smallest chainring (Fig. 1-B). Single and multiple shifts can be made in either direction. If chain rub occurs when the chain is on the middle chainring, trim the front derailleur with either lever A or lever B (Fig. 1-C).

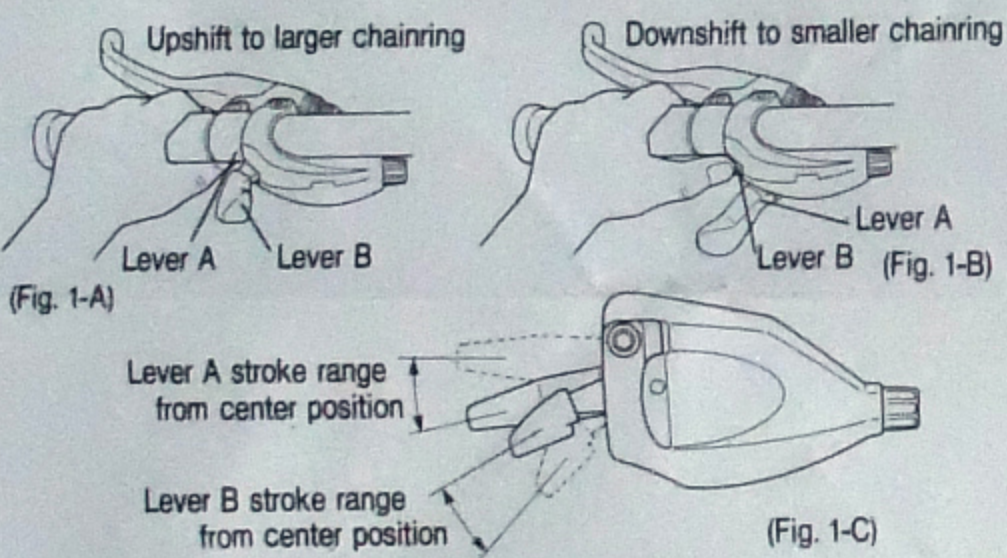

RIGHT LEVER The right lever controls the rear derailleur. Push lever A to downshift from a smaller freewheel cog to a larger freewheel cog (Fig. 1-D). Push lever B to upshift from a larger freewheel cog to a smaller freewheel cog (Fig. 1-E). A firm one-click push of lever A downshifts a single cog. Continuing to push lever A downshifts multiple cogs. A quick, firm push of lever B upshifts a single cog. A rapid sequence of pushes of lever B upshifts multiple cogs.

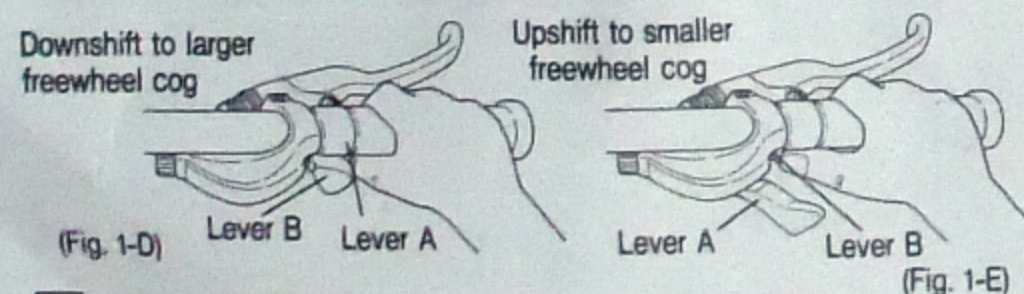

2 MOUNTING THE X-PRESS LEVER TO THE HANDLEBAR

Slide the right X-PRESS lever onto the handlebar. Secure the lever at the appropriate position using the clamp anchor bolt, tightened to the recommended torque of 50kgf·cm, as shown in Fig. 2-A. Follow the same procedure when mounting the left X-PRESS lever.

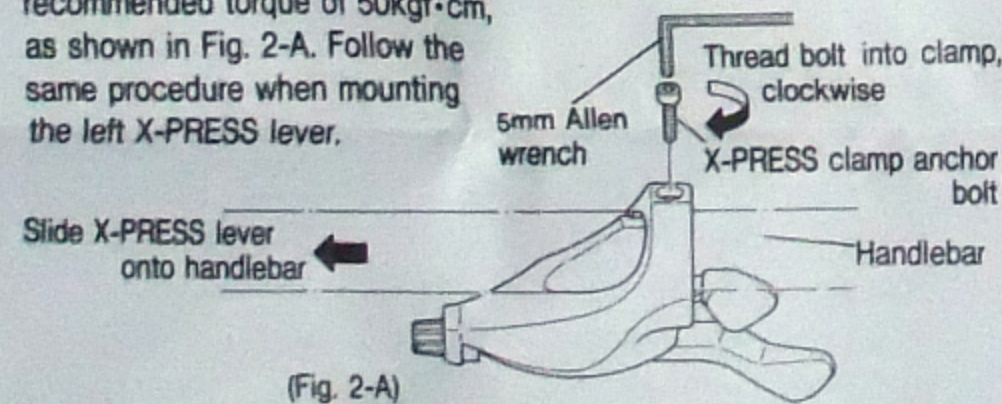

X-PRESS LEVER AND BRAKE LEVER POSITIONING

The correct position for the X-PRESS lever and brake lever is shown in Fig. 2-B.

To prevent interference of the lever clamp and top X-PRESS lever, check that the angle between the centerlines of the shift and brake levers is more than 10°.

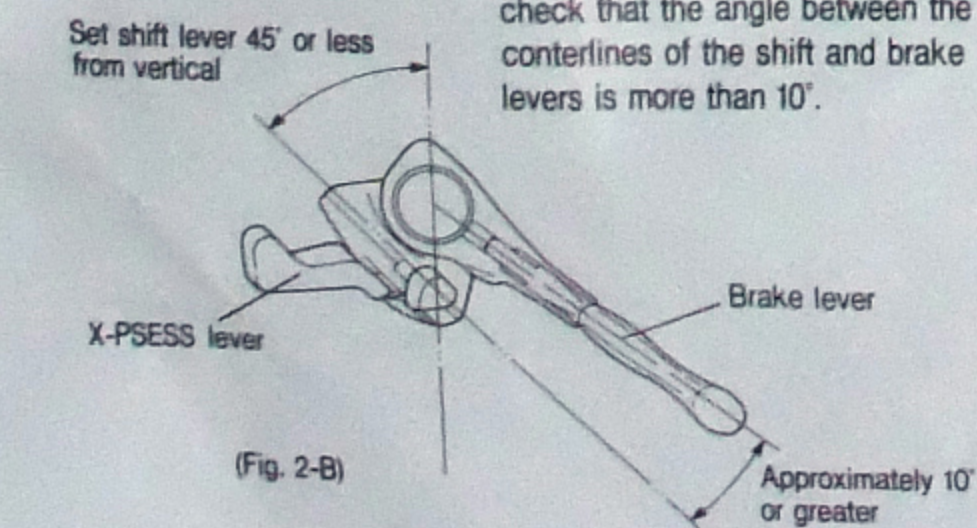

3 SHIFTING ADJUSTMENT RIGHT LEVER

With the chain on the smallest freewheel cog, push lever B until lever A returns to its rearmost position. Make sure that the cable adjusting barrel is turned all the way in (clockwise). Connect the derailleur cable to the rear derailleur (Fig. 3-A).

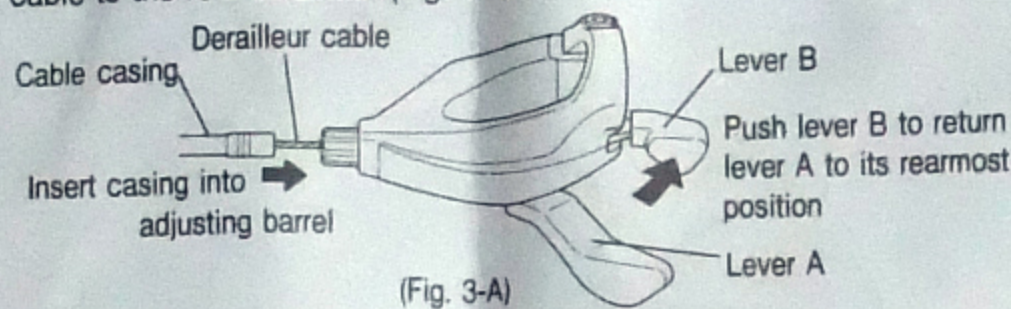

With the chain on the smallest chainring, turn the crank slowly while pushing lever A to the first click position, shifting the chain onto the second smallest freewheel cog.

Center the rear derailleur guide pulley under the same cog by adjusting either the rear derailleur cable adjusting barrel or the shift lever adjusting barrel (Fig. 3-B). Turn the crank slowly, while pushing lever A, to check that the chain shifts up to the larger freewheel cogs.

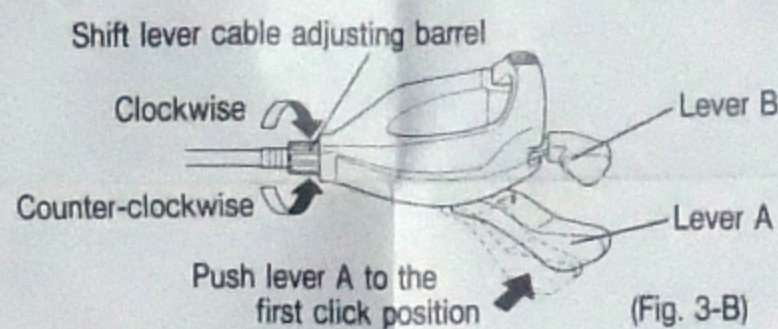

LEFT LEVER

A) Low Gear Adjustment

With the chain on the largest freewheel cog and smallest chainring, turn the crank slowly. There should be 0.5-1.0mm clearance between the inner cage of the front derailleur and the chain (Fig. 3-C). Push lever B until lever A returns to its rearmost position. Make sure that the cable adjusting barrel is turned all the way in (clockwise). Insert the cable casing into the cable adjusting barrel and connect the derailleur cable to the front derailleur (Fig. 3-D).

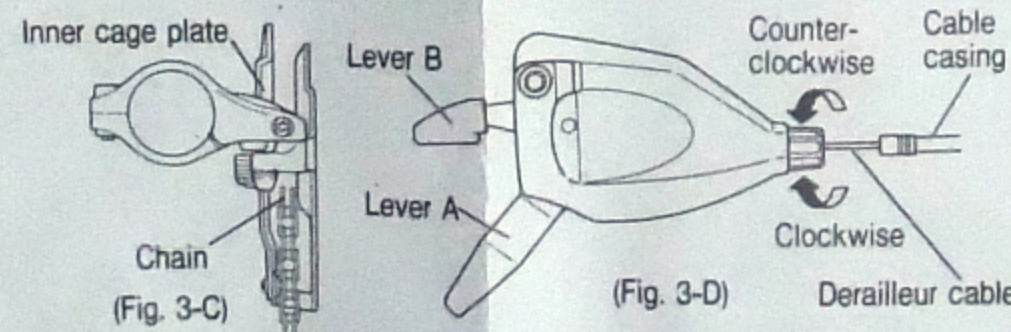

B) Lever Tension Adjustment

Insufficient left lever tension may cause the chain to drop from the large to the middle chainring. If this occurs, adjust the lever as follows.

(1) Center the levers by pushing lever A or B. Without disconnecting the front derailleur cable, unscrew the shift lever cover set screw. Remove the shift lever cover by turning it slightly and pulling down (Fig. 3-E).

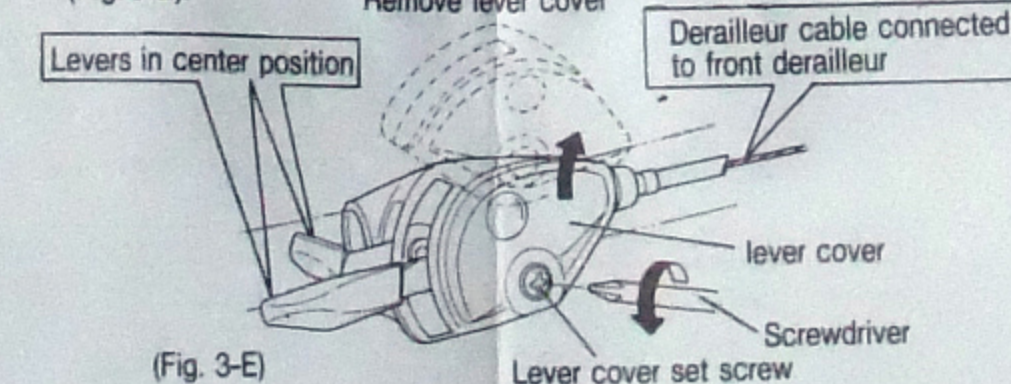

(2) Using a 12mm wrench, tighten the shift lever friction nut no more than 45° by turning the nut clockwise. Fit the cover back on the lever and tighten the set screw to a torque of 20kgf·cm. (Fig. 3-F).

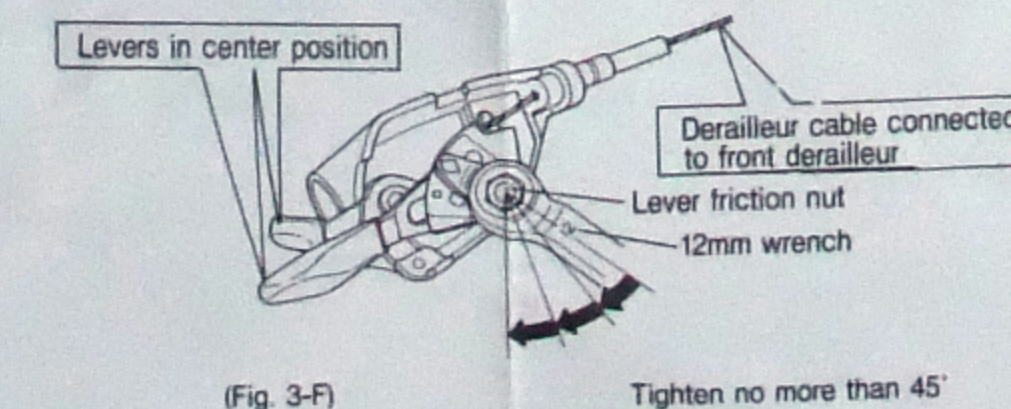

C) Middle Gear Adjustment

While turning the crank, push lever A until it stops and the chain shifts to the largest chainring (Fig. 3-G). If the chain will not shift to the largest chainring, turn the cable adjusting barrel counter-clockwise and repeat the above procedure until the chain makes the shift.

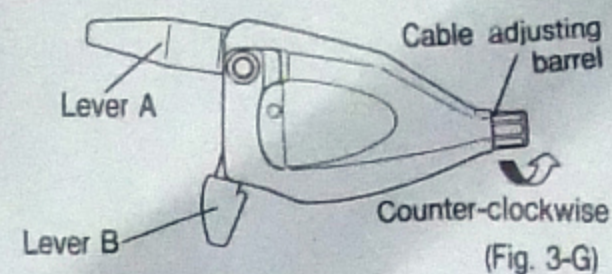

With the chain on the largest chainring, turn the crank and push lever B to the middle click position (Fig. 3-H), shifting the chain to the middle chainring.

Adjust the front derailleur with the cable adjusting barrel (Fig. 3-I) so the chain is close to the inner cage of the front derailleur, but not rubbing.

Turn the cable adjusting barrel clockwise to eliminate chain rub and counter-clockwise to reduce the space between the chain and cage.

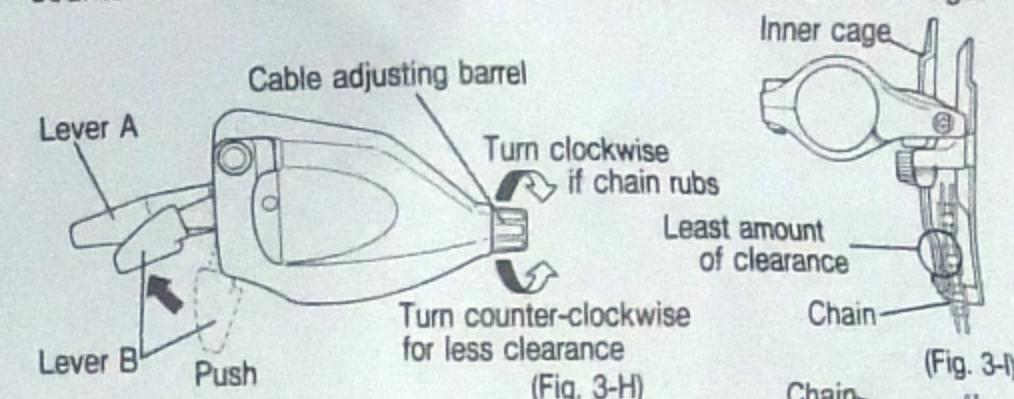

D) High Gear Adjustment

After middle chainring adjustment is completed, push lever A while turning the crank and shift to the largest chainring. Adjustment is correct when the chain has the least amount of clearance, without contacting the inner cage of the front derailleur.

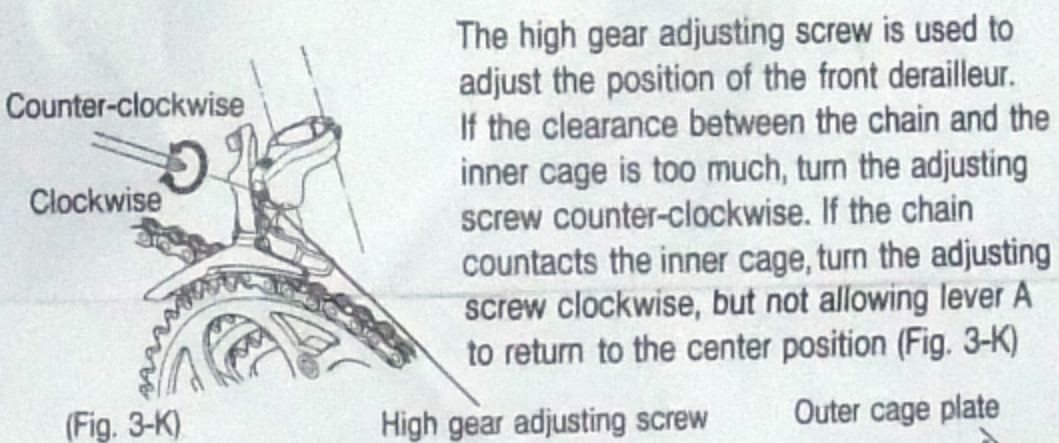

The high gear adjusting screw is used to adjust the position of the front derailleur. If the clearance between the chain and the inner cage is too much, turn the adjusting screw counter-clockwise. If the chain contacts the inner cage, turn the adjusting screw clockwise, but not allowing lever A to return to the center position (Fig. 3-K).

After this adjustment is completed, shift the chain onto the smallest freewheel cog and check the front derailleur for chain rub at the outer cage plate. If necessary, trim with the high gear adjusting screw (Fig. 3-L).

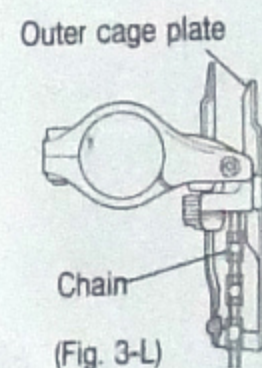

4 CABLE REPLACEMENT

To replace the derailleur cables, position the front and rear shift levers as shown in figs. 4-A and 4-B. To remove the shift lever cover, unscrew the shift lever cover set screw. Turn the cover slightly and pull down. Replace the cables.

Note: The cable installation procedure differs for the two levers; the front cable end is inserted from above the cable socket, while the rear cable end is inserted from below the cable socket (figs 4-B & 4-C).

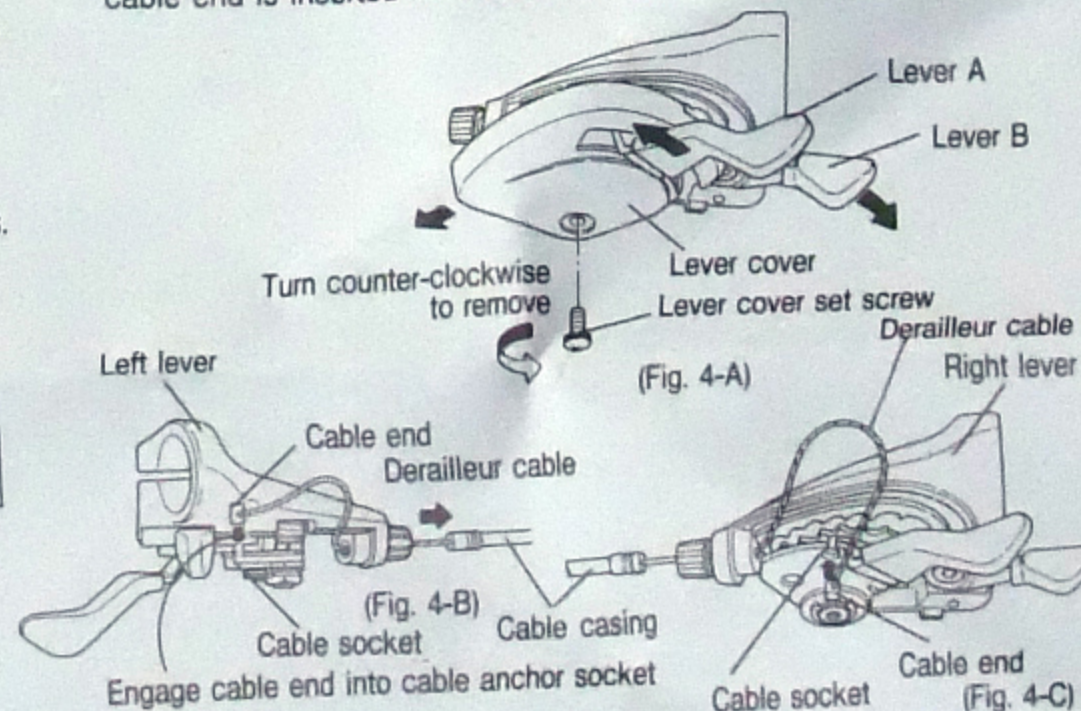

5 ATTACHING COVER

Fit the cover on the right lever while slightly turning it (Fig. 5-A). Secure the cover by tightening the set screw to the recommended torque of 20kgf·cm. (Fig. 5-B).

Follow the same procedure for the left lever. The left lever is spring-loaded, and care should be taken when the levers return to their un sprung position.

