

SunTour

GENUINE PARTS

MODEL: FD-1000 **SPIRT**
FRONT DERAILLEUR
DERAILLEUR AVANT

MAEDA INDUSTRIES, LTD.
PRODUCT OF JAPAN

FRONT DERAILLEUR & MULTIPLE FREEWHEEL

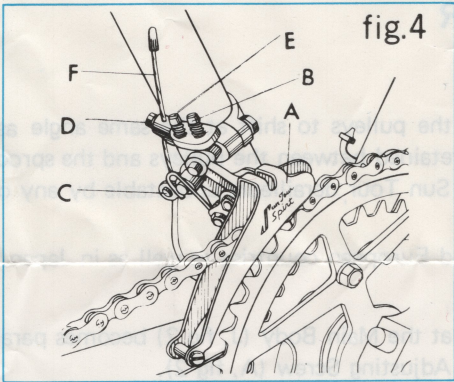

fig. 4

FRONT DERAILLEUR SL, COMPE-V & SPIRT

Fix the Front Derailleur to the bicycle seat tube (A, fig 6, 7) and set the chain guide (B, fig 6, 7) 1 mm (one millimeter) above the teeth of the largest sprocket. The chain guide should be parallel to the Crank Sprocket (C, fig 6, 7).

Adjust the Front Derailleur by turning the Adjusting Screw (B, fig 4, 5) so that the chain guide is centered over the outer crank sprocket.

Connect the wire coming from the lever to the Anchor Screw (D, fig 4, 5) after passing through the Outer Stop Guide (C, fig 4, 5). Before tightening the anchor screw, be sure that the lever is in a full forward position and that the Inner Wire (F, fig 4, 5) is pulled tight.

Turn the bicycle gear crank slowly forward and slowly shift the chain guide to the small sprocket by pulling the shifting lever to a full back position.

Adjust the chain guide until it becomes centered over the smallest crank sprocket by turning the Adjusting Screw (E, fig 4, 5).

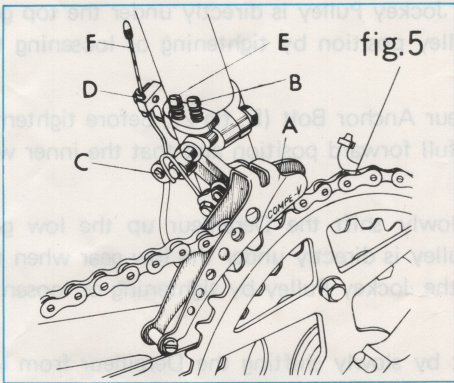
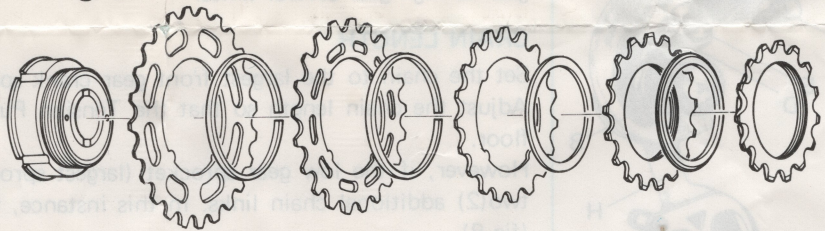

fig. 5

MULTIPLE FREEWHEEL

18	22	27	17	22	28	16	21	27		
19	23	28	18	23	30	17	22	28	15	14
20	24	30	19	24	32	18	23	30	16	15
21	26	32	20	26	34	19	24	32	17	16
		34	21	27		20	26	34	18	17

fig. 9



ANY SIZE SPROCKET IS AVAILABLE 14T~34T
(except: 25, 29, 31 and 33)

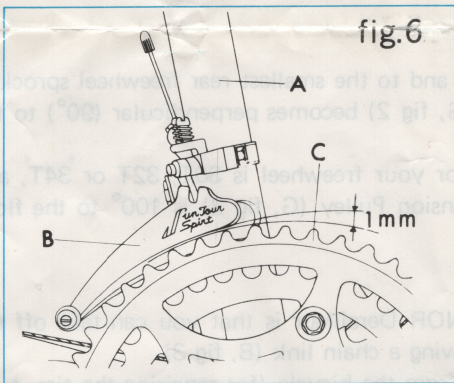

fig. 6

RATIOS OF MULTIPLE FREEWHEEL

Standard 5-speed Multiple Freewheels:

Racing Model	14 X 15 X 17 X 19 X 21T
Standard Model	15 X 17 X 19 X 21 X 24T
Wide Model	14 X 17 X 20 X 24 X 28T
Ultra Model	14 X 18 X 22 X 26 X 30T
GT Model	14 X 18 X 22 X 27 X 34T

Other ratios will be available to your order.

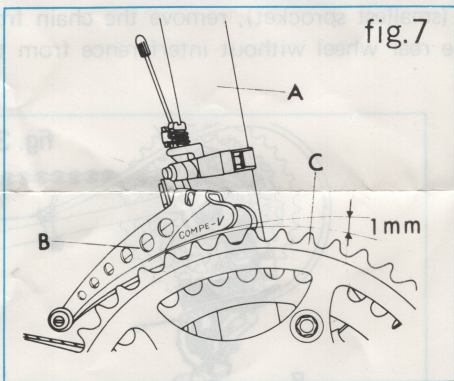
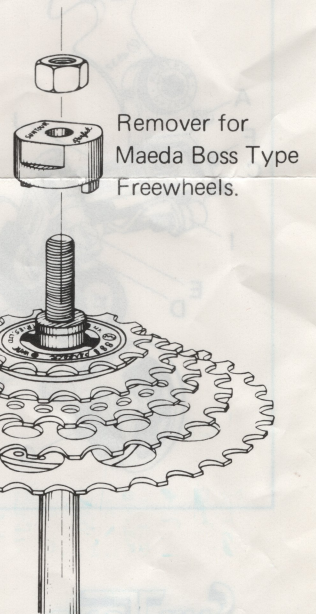

fig. 7



Maeda 8.8.8. freewheels are specially designed enabling the sprockets to be quickly and easily changed.

It is possible to change the sprockets without removing the freewheel from the hub as all sprockets are removable from the outside. Spokes may now be replaced on large flange hubs without removing the complete freewheel.

The freewheel body is cut at two (2) points, thickened, and heat-treated, so that the removal of freewheels is easy and secure.

REAR DERAILLEUR GT & HONOR

SLANT PANTOGRAPH MECHANISM

Ensures a smoother change in all ranges of speed.

Maeda's unique slant pantograph mechanism enables the pulleys to shift at the same angle as the gear block during gear change. The uniform clearance retained between the pulleys and the sprockets assures more stable driving and easier shifting, making Sun Tour derailleurs unbeatable by any other competing models.

This epoch-making mechanism is patented in U.S.A. and European countries as well as in Japan.

ANGLE SETTING

Set the chain on the top gear (smallest sprocket) so that the Main Body (J, fig 2) becomes parallel to the chain stay by tightening or loosening the Angle Adjusting Screw (A, fig 2).

To Set the Jockey Pulley (B, fig 2). Be sure that the Jockey Pulley is directly under the top gear (smallest sprocket). If it is not, adjust the Jockey Pulley position by tightening or loosening the Adjusting Screw "C" (C, fig 2).

Connect the wire coming from the lever to the Derailleur Anchor Bolt (E, fig 2). Before tightening the Anchor Bolt, be certain that the shift lever is in a full forward position and that the inner wire is pulled tight.

Turn the Bicycle Gear Crank slowly forward and slowly shift the Derailleur up the low gear sprocket (largest sprocket). Be sure that the Jockey Pulley is directly under the low gear when the shifting lever is pulled to a full back position. Adjust the Jockey Pulley by tightening or loosening the Adjusting Screw "F". (F, fig 2).

The Derailleur should now be perfectly adjusted. Test by slowly shifting the Derailleur from low gear to high gear several times.

CHAIN LENGTH

Set the chain to the largest front gear crank sprocket and to the smallest rear freewheel sprocket. Adjust the chain length so that the Tension Pulley (G, fig 2) becomes perpendicular (90°) to the floor.

However, if the low gear sprocket (largest sprocket) or your freewheel is 30T, 32T or 34T, add two(2) additional chain links. In this instance, the Tension Pulley (G, fig 2) is 100° to the floor (fig 8).

SPECIAL FEATURE

One of the distinguished features of the GT and HONOR Derailleur is that you can take off the chain from the Derailleur Cage (A, fig 3) without removing a chain link (B, fig 3).

When it becomes necessary to remove the rear wheel from the bicycle (for repairing the tire, tube or rear hub), simply shift the Derailleur to high gear (smallest sprocket), remove the chain from the Derailleur Cage, and you may easily drop out the rear wheel without interference from the chain.

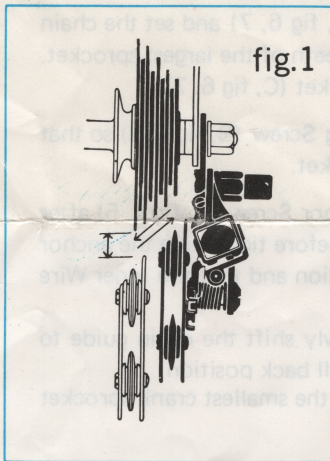

fig. 1

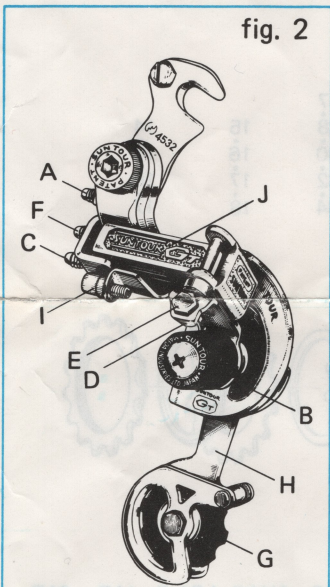

fig. 2

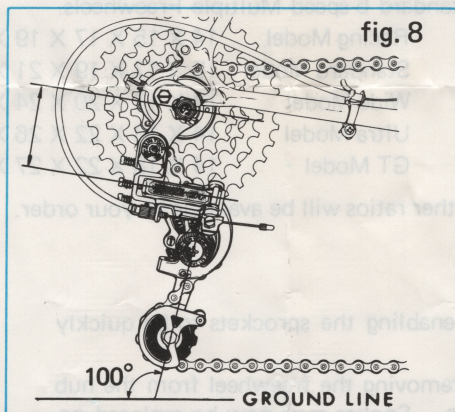
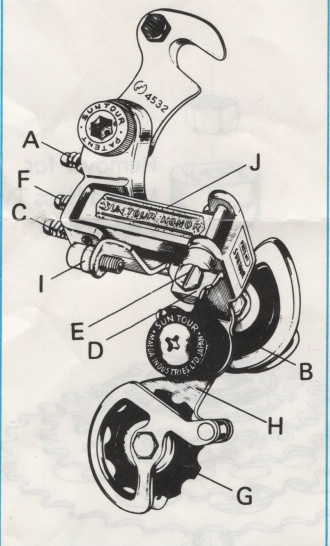

fig. 8

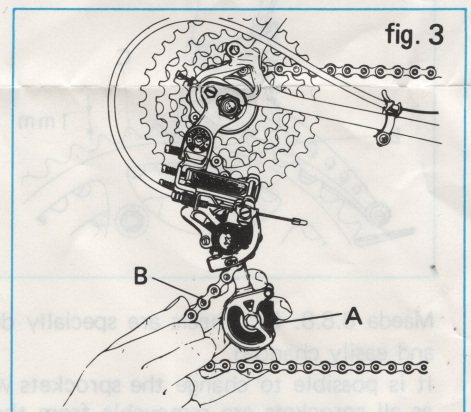

fig. 3

MAEDA INDUSTRIES, LTD.

Head Office : No. 1 Minami Koyochi 2-cho, Sakai, Osaka, Japan
 Cable Address: 888 SAKAI, P.O. Box SAKAI-38, Phone: 0722(38)4561~6, TELEX: 5374-377
 Mihara Factory : 97 Tannan Miharacho, Minamikawachigun, Osaka, Japan Phone: 0723(61)1888~90(61)3211~2
 SHIGA Factory : 523 Sinjo Minakuchicho, Kogagun, Shiga, Japan Phone: 07486(2)0841
 TOKYO Office : 3-8-8 Ueno, Taitoku, Tokyo Phone: 03(832)6895~6
 MAEDA INDUSTRIES OF U.S.A. INC. : 461 ROUTE 46 FAIRFIELD NEW JERSEY 07006 PHONE: 201-575-1128